

JUMP Math Inf.1

Libro Inf Parte 1 de 2

Índice

Unidad 1: Contar y numerar: números del 1 al 5	1
Unidad 2: Contar y numerar: comparar números del 1 al 5	39
Unidad 3: Geometría: figuras planas	69
Unidad 4: Contar y numerar: números del 6 al 10	107
Unidad 5: Contar y numerar: comparar hasta el 10	133
Unidad 6: Medidas y datos: categorías y clasificación	159

¡Pon aquí tu nombre
o tu foto!



Copyright © 2017 JUMP Math

Se pueden reproducir fragmentos extraídos de esta publicación con el consentimiento escrito de JUMP Math o bajo el amparo de la ley.

En cualquier otro caso se reservan los derechos. Por tanto, se prohíbe la reproducción, el almacenamiento y la cesión de esta publicación de todas las maneras o a través de cualquier medio (electrónico, mecánico, fotocopia, escaneo, grabación, entre otros) excepto que se autorice de manera explícita.

UpSocial

www.upsocial.org

www.jumpmath.cl

Autores: Dr. Heather Betel, Dr. Francisco Kibedi, Julie Lorinc

Editores: Megan Burns, Liane Tsui, Julie Takasaki, Natalie Francis, Jackie Dulson, Janice Dyer, Rita Vanden Heuvel

Diseño e ilustraciones: Linh Lam, Fely Guinasao-Fernandes, Sawyer Paul

Diseño de la portada: Blakeley Words+Pictures

Fotografía de la portada: © Photo Pegah

Primera edición en español: septiembre de 2017

Publicado por UpSocial bajo acuerdo de licencia con JUMP Math (www.jumpmath.org).

Publicado originalmente por JUMP Math en inglés en Estados Unidos en 2016 bajo el título JUMP Math Assessment & Practice Book K.2 (ISBN 978-1-927457-72-6).

Traducción, corrección y revisión: L'Apòstrof, SCCL (Alicia Almonacid, Laia Brossa, Mar Esteller, Eva Girona, Núria Vila)

Impresión: Salesianos Impresores S.A.

ISBN: 978-84-947359-3-6

Depósito legal: B 16972-2017

Impreso en Santiago, Chile, 2020



Nota para educadores, familias y todos los que piensen que las matemáticas son tan importantes como las lenguas para el pleno funcionamiento de la sociedad.

Bienvenido a JUMP Math

Entrar en el mundo de JUMP Math significa creer que todos los niños y niñas tienen habilidades para la aritmética y para disfrutar de las matemáticas. El fundador y matemático John Mighton ha utilizado esta premisa para desarrollar este método innovador. Los recursos del programa aíslan y describen los conceptos de una manera tan clara y gradual que cualquiera puede entenderlos.

El programa JUMP Math consta de guías para los docentes (el núcleo del programa), lecciones interactivas para realizar en la pizarra, libros de práctica y evaluación para los alumnos, materiales de evaluación, programas de divulgación y formación para docentes. Para más información visiten la web de JUMP Math: www.jumpmath.es

Los educadores de los centros que implantan JUMP Math tienen acceso a las guías para docentes en nuestra web. Recomendamos que lean la introducción antes de utilizar estos recursos para poder entender la filosofía y la metodología de JUMP Math. Los libros de práctica y evaluación están pensados para que los alumnos los usen con la ayuda de adultos. Cada estudiante tiene unas necesidades únicas y es importante darle apoyo y animarlo a medida que trabaja el material.

Siempre que sea posible, dejen que los alumnos descubran los conceptos por sí mismos. En el ámbito de las matemáticas, los descubrimientos se pueden realizar de manera progresiva. Descubrir un paso nuevo es como encajar piezas de un rompecabezas: emocionante y gratificante.

Los ejercicios marcados con el dibujo  deben realizarse en un cuaderno. Es necesario que los alumnos dispongan de un cuaderno de papel cuadriculado para resolver los ejercicios extras o por si necesitan espacio adicional para realizar cálculos.

Índice

PARTE 1

Unidad 1: Contar y numerar: números del 1 al 5

CCInf-1	Contar del 1 al 10	1
CCInf-2	Los números 1 y 2	4
CCInf-3	El número 3	7
CCInf-4v	Contar	10
CCInf-5	Contar 1, 2 y 3	12
CCInf-6	Contar 1, 2 y 3 (ampliación)	14
CCInf-7	Escribir el 1, el 2 y el 3	16
CCInf-8	Contar 4	19
CCInf-9	El número 4	22
CCInf-10	Escribir el 4	26
CCInf-11	Contar 5	28
CCInf-12	El número 5	32
CCInf-13	Escribir el 5	35
CCInf-14	Repaso de 1, 2, 3, 4 y 5	37

Unidad 2: Contar y numerar: comparar números del 1 al 5

CCInf-15	Contar hasta el 20	39
CCInf-16	<i>Más</i>	40
CCInf-17	<i>Igual a</i> (relacionar)	44
CCInf-18	<i>Igual a</i> (contar)	47
CCInf-19	<i>Mayor que</i> (relacionar)	50
CCInf-20	<i>Mayor que</i> (contar)	52
CCInf-21	<i>Menor que</i> (relacionar)	55
CCInf-22	<i>Menor que</i> (contar)	58
CCInf-23	Cero	61
CCInf-24	Comparar números del 1 al 5	65

Unidad 3: Geometría: figuras planas

GInf-1	Contar hasta el 30	69
GInf-2	Círculos	70
GInf-3	Cuadrados	73
GInf-4	Rectángulos	76
GInf-5	Esquinas y lados	79
GInf-6	Contar esquinas y lados	81
GInf-7	Más cuadrados y rectángulos	85
GInf-8	Triángulos	89
GInf-9	Describir y comparar figuras	92
GInf-10	Figuras abiertas y figuras cerradas	94
GInf-11	<i>Encima</i>	96
GInf-12	<i>Debajo</i>	99
GInf-13	<i>Al lado</i>	102
GInf-14	Componer figuras	104

Unidad 4: Contar y numerar: números del 6 al 10

CCInf-25	Contar hasta el 40	107
CCInf-26	Contar 6 y 7	108
CCInf-27	Los números 6 y 7	111
CCInf-28	Escribir el 6 y el 7	114
CCInf-29	Contar 8 y 9	116
CCInf-30	Los números 8 y 9	119
CCInf-31	Escribir el 8 y el 9	122
CCInf-32	Contar 10	124
CCInf-33	El número 10	127
CCInf-34	Escribir el 10	129
CCInf-35	Repaso de 0 a 10	131

Unidad 5: Contar y numerar: comparar hasta el 10

CCInf-36	Contar hasta el 50	133
CCInf-37	<i>Igual a</i>	134
CCInf-38	<i>Mayor que</i>	140
CCInf-39	<i>Menor que</i>	146
CCInf-40	<i>Uno más que</i>	152
CCInf-41	Comparar números	156

Unidad 6: Medidas y datos: categorías y clasificación

MDInf-1	Contar hasta el 60	159
MDInf-2	Clasificar en dos grupos	160
MDInf-3	Clasificar en tres grupos	164
MDInf-4	Varias maneras de clasificar	168
MDInf-5	Clasificar por número de esquinas y lados	170

PARTE 2

Unidad 7: Operaciones y razonamiento algebraico: sumar hasta 5

OAIInf-1	Contar hasta el 70	1
OAIInf-2	Contar hasta 5 a partir de un número	2
OAIInf-3	Representar la suma	5
OAIInf-4	Sumar con objetos	7
OAIInf-5	Sumar con dibujos	10
OAIInf-6	Agrupar con objetos	13
OAIInf-7	Agrupar con dibujos (1)	16
OAIInf-8	Agrupar con dibujos (2)	20
OAIInf-9	Descomponer el 5	23
OAIInf-10	Descomponer hasta el 5	25
OAIInf-11	Sumar	28
OAIInf-12	Sumar 0 y 1	30

Unidad 8: Operaciones y razonamiento algebraico: sumar hasta 10

OAlnf-13	Contar hasta el 80	33
OAlnf-14	Contar hasta 10 a partir de un número	34
OAlnf-15	Representar la suma hasta 10	37
OAlnf-16	Sumar hasta 10 con objetos (1)	39
OAlnf-17	Sumar hasta 10 con dibujos (1)	42
OAlnf-18	Sumar hasta 10 con objetos (2)	46
OAlnf-19	Sumar hasta 10 con dibujos (2)	49
OAlnf-20	Descomponer el 10	53
OAlnf-21	Descomponer hasta el 10	56
OAlnf-22	Sumar hasta 10	59
OAlnf-23	Completar hasta 10	63
OAlnf-24	Obtener 10	65

Unidad 9: Geometría: cuerpos geométricos

Glnf-15	Contar hasta el 90	69
Glnf-16	Esferas y cubos	70
Glnf-17	Cilindros y conos	75
Glnf-18	Caras y esquinas	79
Glnf-19	<i>Delante y detrás</i>	83
Glnf-20	<i>Junto a</i>	85
Glnf-21	Construir cuerpos geométricos	87

Unidad 10: Números y operaciones en base diez: números del 11 al 20

NBTlnf-1	Contar hasta el 100	89
NBTlnf-2	Los números 11, 12 y 13	90
NBTlnf-3	Descomponer el 11, el 12 y el 13	94
NBTlnf-4	Obtener 11, 12 y 13	97
NBTlnf-5	Los números 14, 15 y 16	100
NBTlnf-6	Descomponer el 14, el 15 y el 16	104
NBTlnf-7	Obtener 14, 15 y 16	107
NBTlnf-8	Los números 17, 18 y 19	110
NBTlnf-9	Descomponer el 17, el 18 y el 19	114
NBTlnf-10	Obtener 17, 18 y 19	117
NBTlnf-11	El número 20	120
NBTlnf-12	Contar hasta 20 con tablas	123

Unidad 11: Operaciones y razonamiento algebraico: restar hasta 5

OAlnf-25	Contar de 10 en 10	125
OAlnf-26	Representar la resta	127
OAlnf-27	Restar con objetos (1)	130
OAlnf-28	Restar con objetos (2)	134
OAlnf-29	Restar con dibujos	138
OAlnf-30	Restas	142
OAlnf-31	Restar	145

OAIInf-32	Escribir restas	148
OAIInf-33	Componer el 5	150

Unidad 12: Operaciones y razonamiento algebraico: restar hasta 10

OAIInf-34	Contar hasta 50 a partir de un número	153
OAIInf-35	Representar la resta hasta 10	155
OAIInf-36	Restar de 10 con objetos	157
OAIInf-37	Restar hasta 10 con objetos	160
OAIInf-38	Restar hasta 10 con dibujos	163
OAIInf-39	Restar hasta 10	166
OAIInf-40	Escribir restas hasta 10	169
OAIInf-41	Componer el 10	173

Unidad 13: Operaciones y razonamiento algebraico: fluidez hasta 5

OAIInf-42	Contar hasta 100 a partir de un número	177
OAIInf-43	Sumar números pequeños	180
OAIInf-44	Fluidez con la suma	184
OAIInf-45	Restar números pequeños	187
OAIInf-46	Fluidez con la resta	190
OAIInf-47	Familias de números	193
OAIInf-48	Sumar números al 5	197

Unidad 14: Medidas y datos: medidas

MDInf-6	Capacidad	199
MDInf-7	Altura	201
MDInf-8	Longitud	204
MDInf-9	Peso	207
MDInf-10	Formas de ser mayor o menor	209
MDInf-11	Componer figuras (ampliación)	212



CCInf-1 Contar del 1 al 10

Colorea.

1.

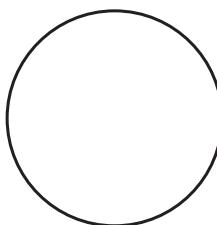

2.

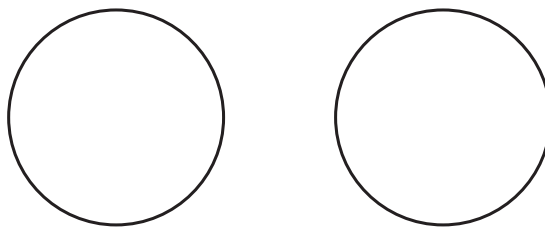

Colorea.

3.

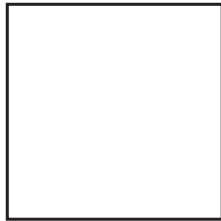

4.

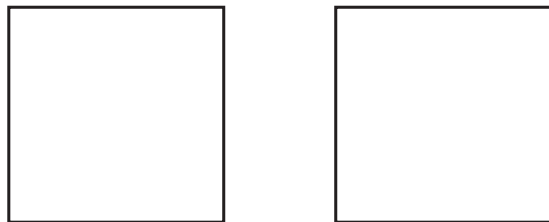

Colorea.

5. EXTRA

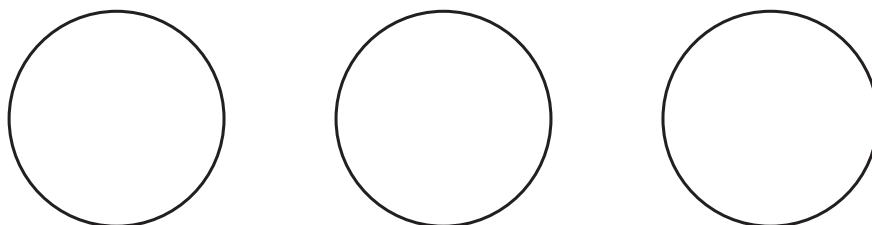

6. EXTRA



CCInf-2 Los números 1 y 2

Pega el número 1 o 2.

1.

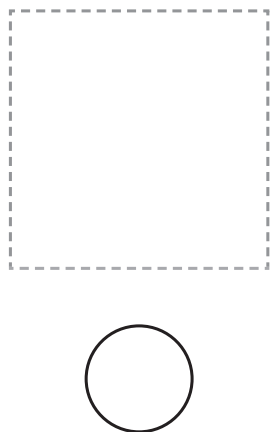

2.

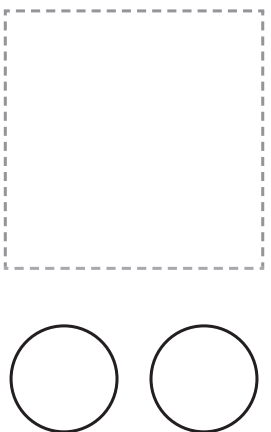

3.

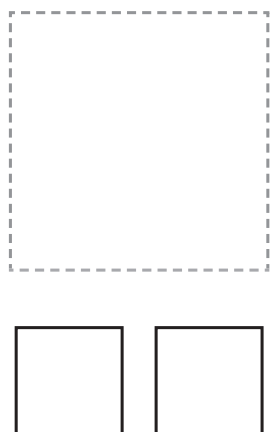

4.

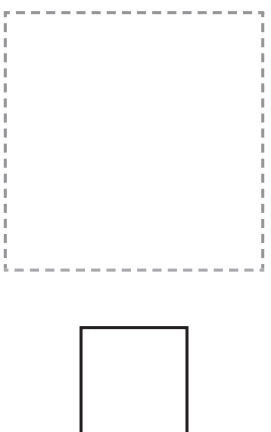

5.

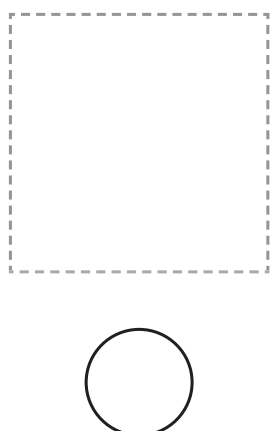

6.

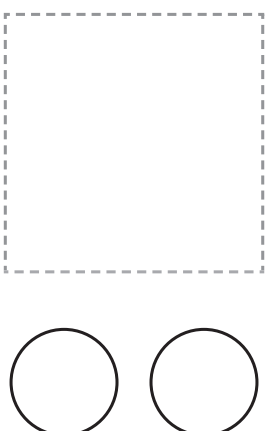

COPYRIGHT © 2017 JUMP MATH: PROHIBIDA LA REPRODUCCIÓN. EDICIÓN EN ESPAÑOL

Pega un dibujo de 1 o 2.

7.



2

8.



1

9.



1

10.



2

11.



2

12.



1

COPYRIGHT © 2017 JUMP MATH: PROHIBIDA LA REPRODUCCIÓN. EDICIÓN EN ESPAÑOL

EXTRA: Colorea 😊 si coincide. Colorea ☹️ si no coincide.

13.

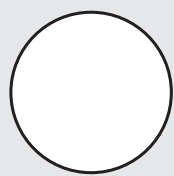

1



14.



2



15.

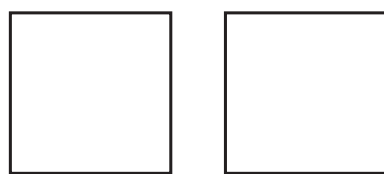

2



16.

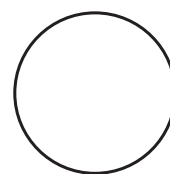

1



17.

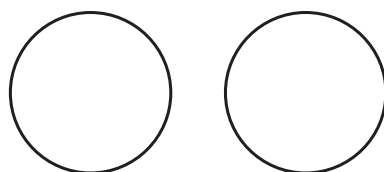

1



18.

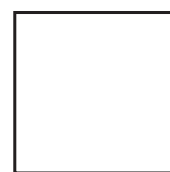

2



CCInf-3 El número 3

Pega el número 1, 2 o 3.

1.

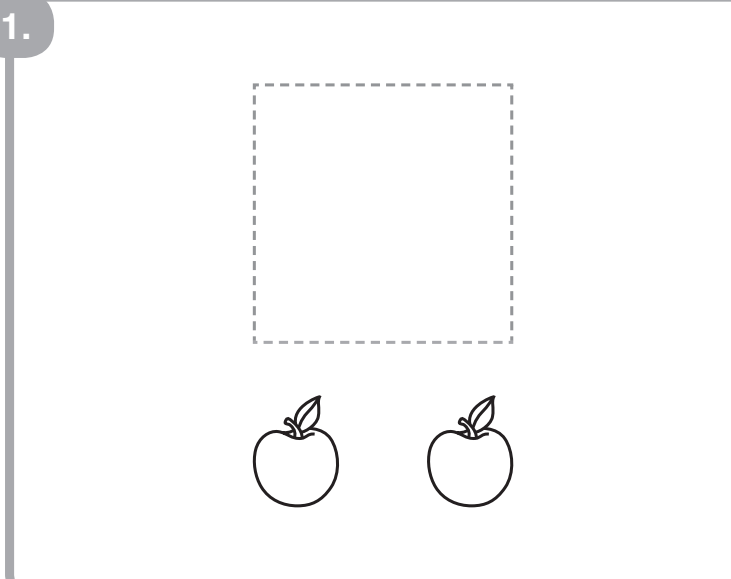

Two apples are shown below a dashed square box, indicating that the number 2 should be pasted into the box.

2.

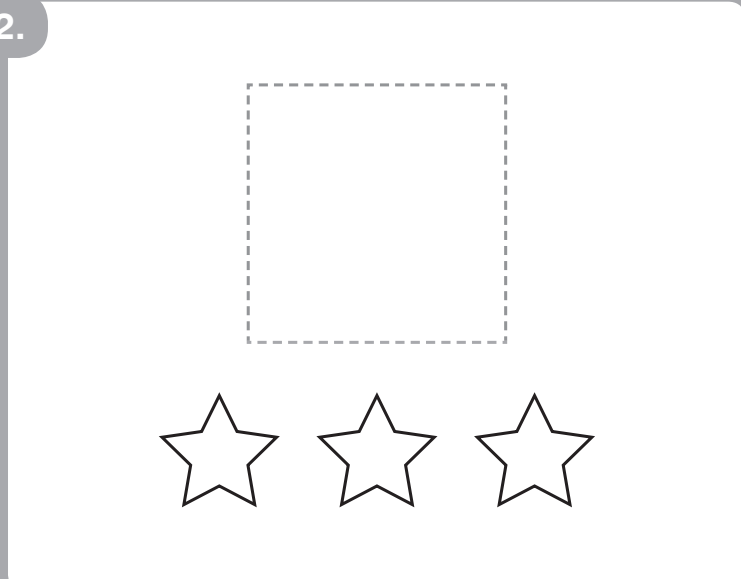

Three stars are shown below a dashed square box, indicating that the number 3 should be pasted into the box.

3.

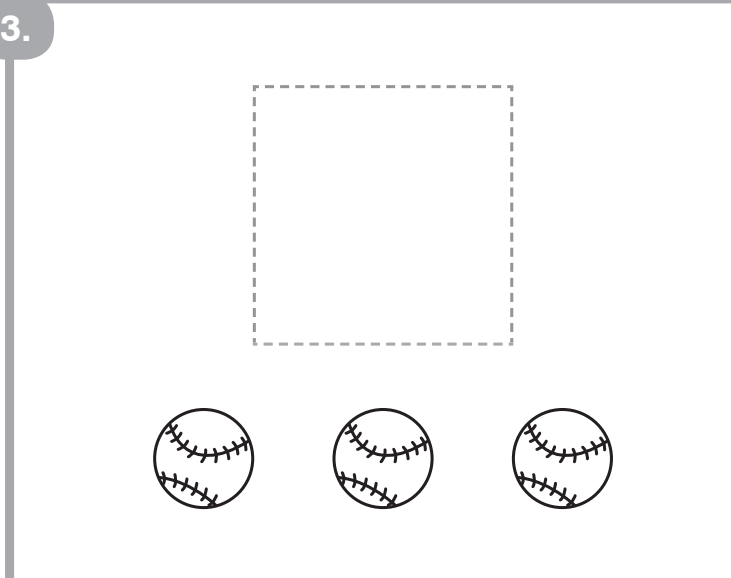

Three baseballs are shown below a dashed square box, indicating that the number 3 should be pasted into the box.

4.

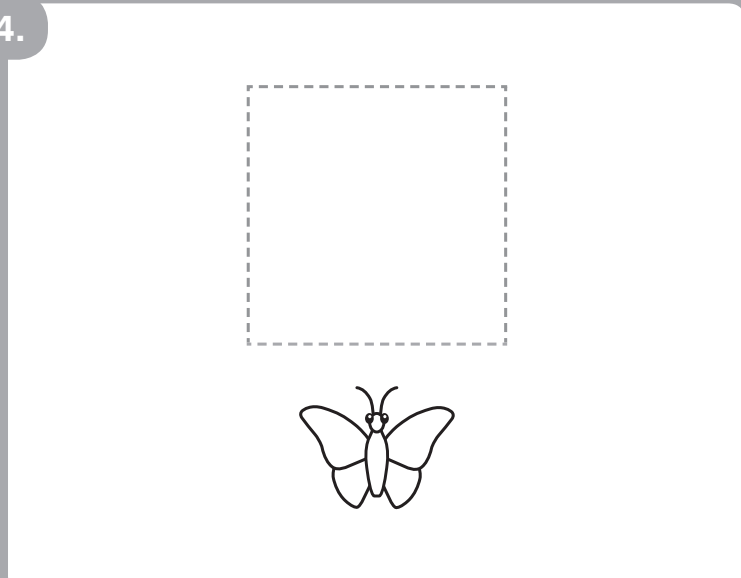

One butterfly is shown below a dashed square box, indicating that the number 1 should be pasted into the box.

5.

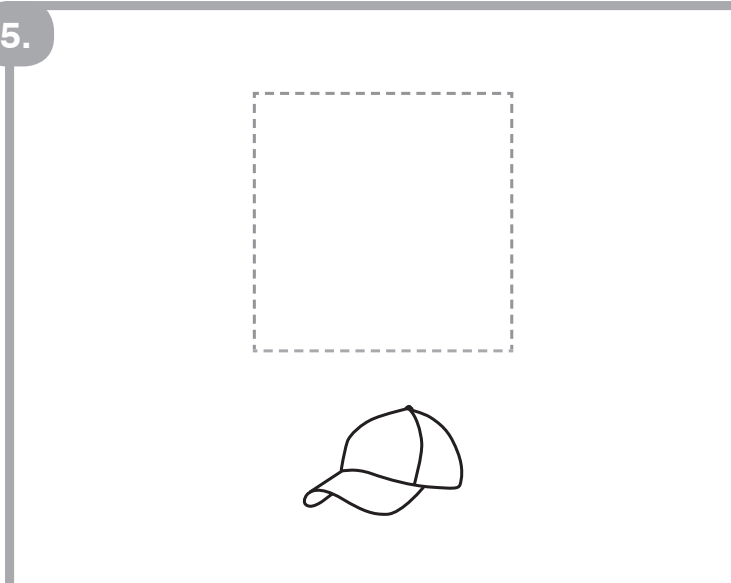

One baseball cap is shown below a dashed square box, indicating that the number 1 should be pasted into the box.

6.

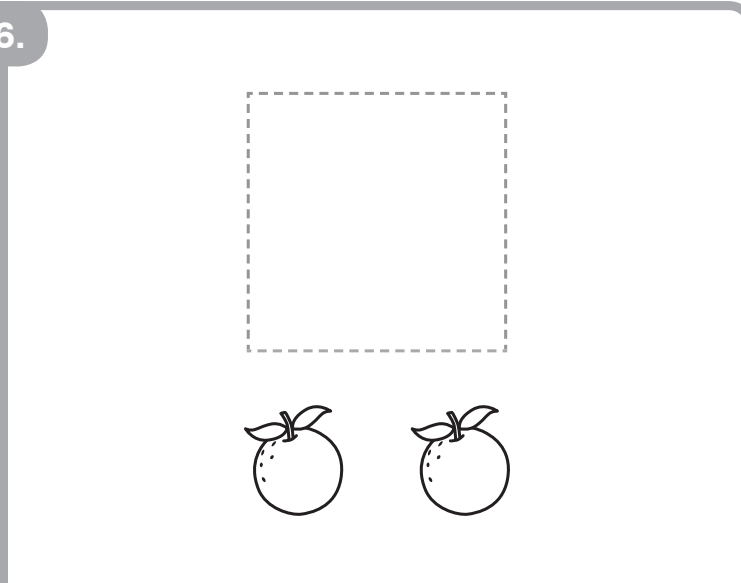

Two oranges are shown below a dashed square box, indicating that the number 2 should be pasted into the box.

Pega un dibujo de 1, 2 o 3.

7.



2

8.



1

9.



3

10.



2

11.



1

12.





3

EXTRA: Colorea 😊 si es correcto. Colorea ☹ si no es correcto.

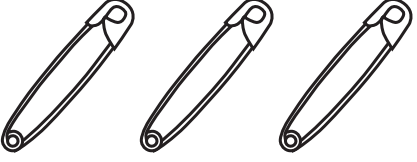
13.





2

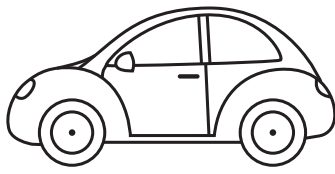

14.





1



15.





1



16.





3

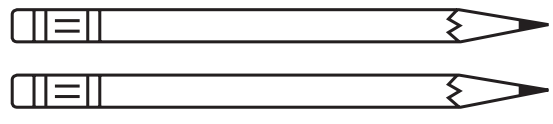

17.





2

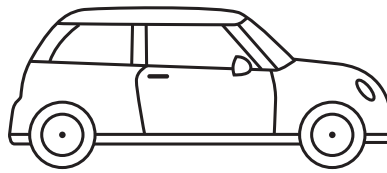

18.



3



CCInf-4 Contar

Cuenta.

1.

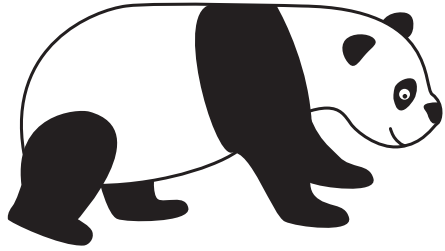

2.

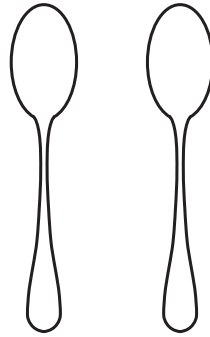

3.

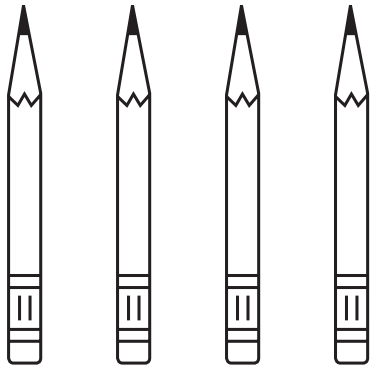

4.



5.

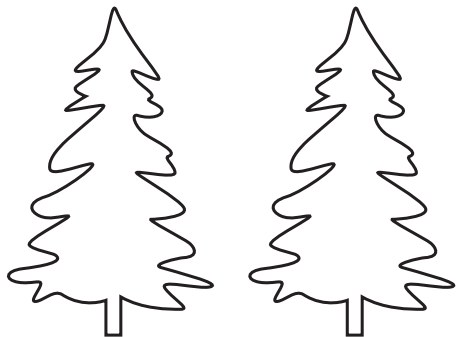

6.

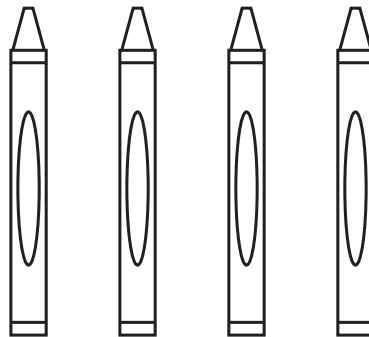

Cuenta.

7.

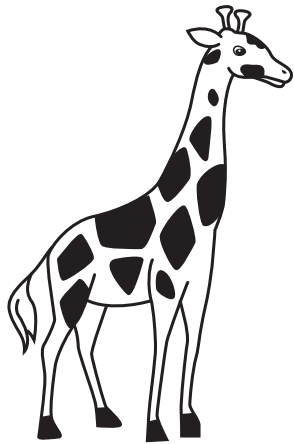

8.

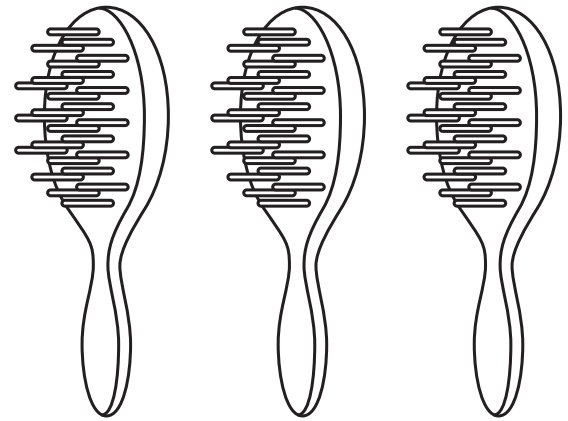

9.

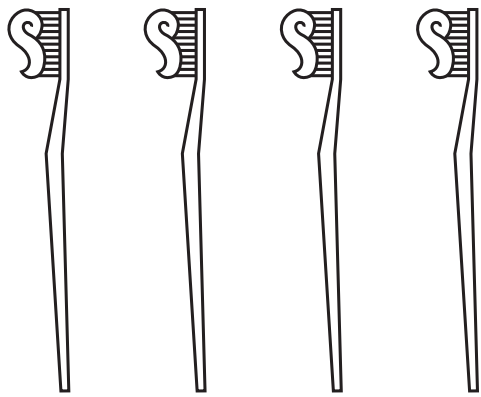

10.

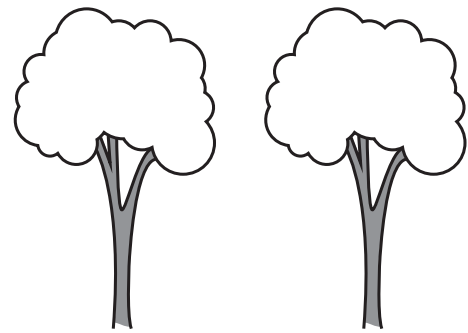

11.

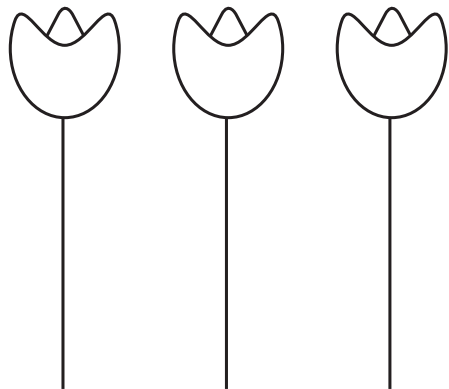

12.

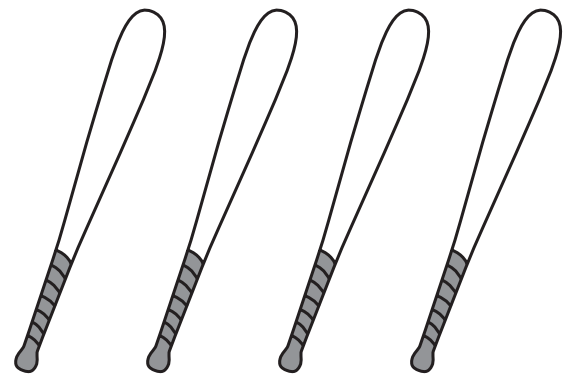

CCInf-5 Contar 1, 2 y 3

Cuenta y rodea el número.

1.

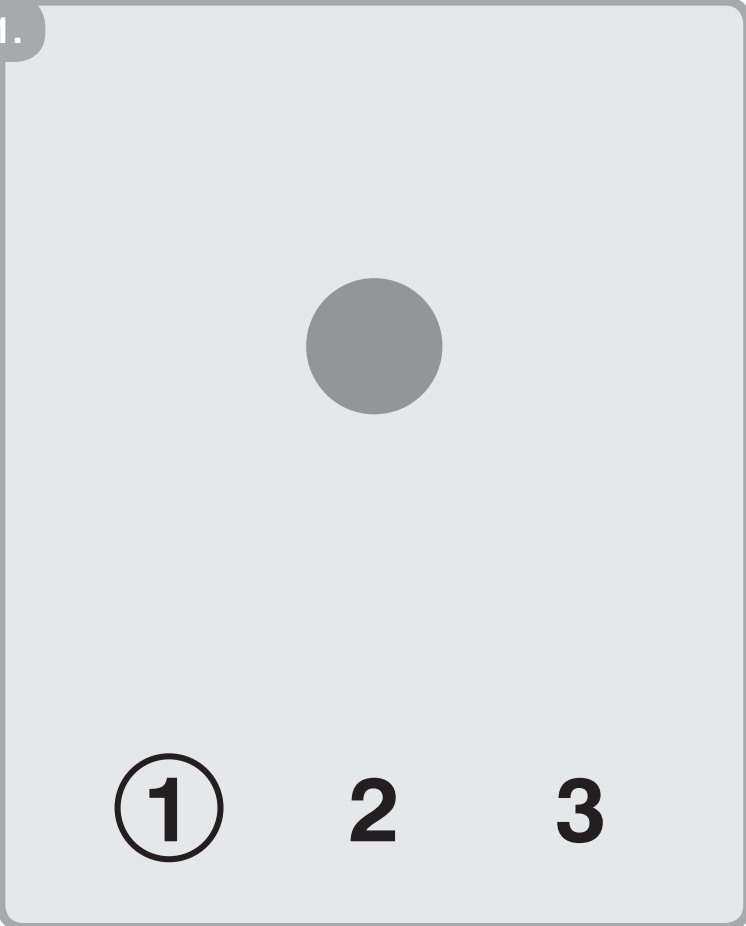

1 2 3

2.

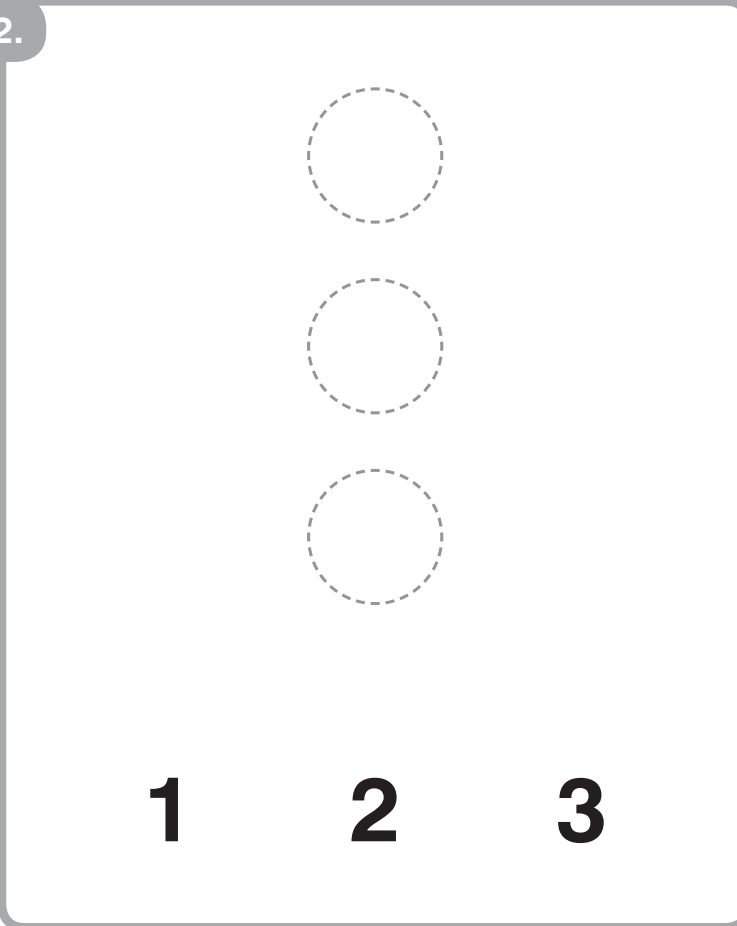

1 2 3

3.

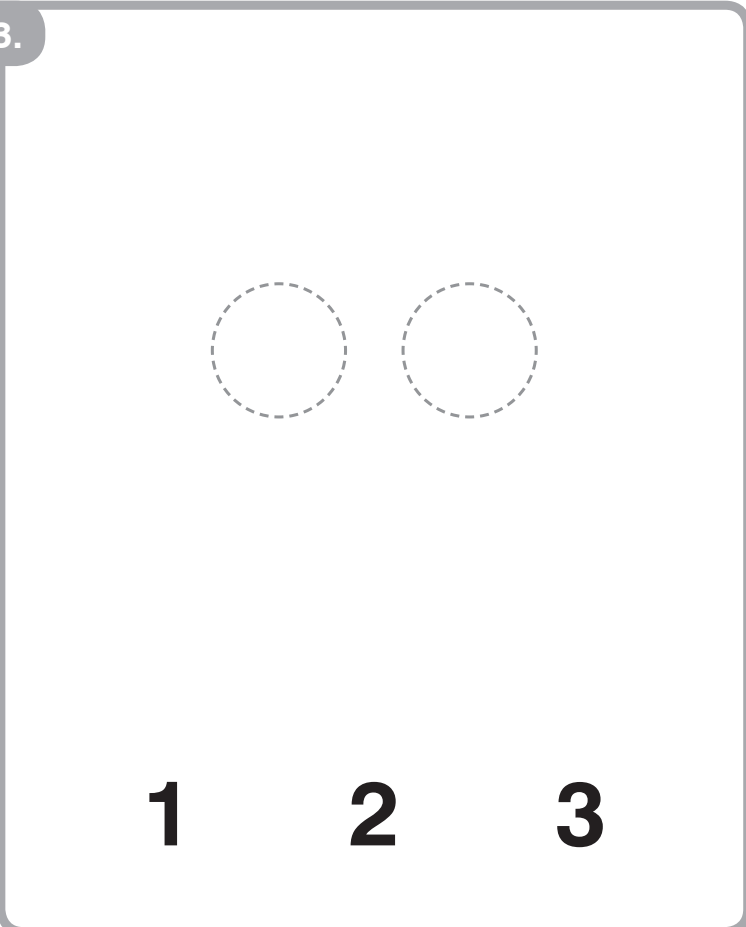

1 2 3

4.

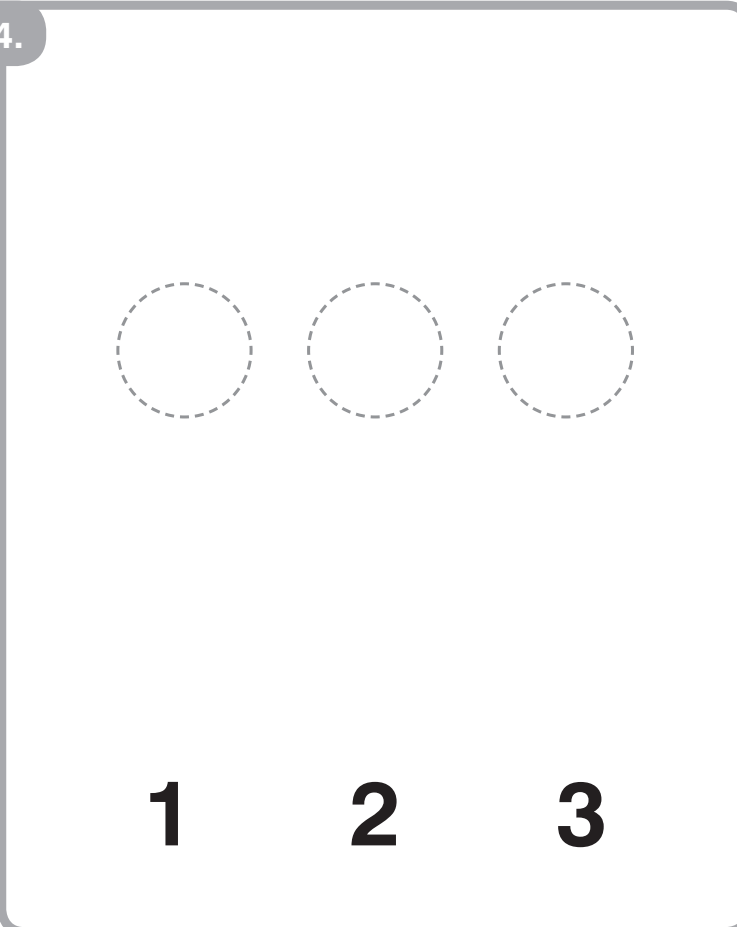

1 2 3

COPYRIGHT © 2017 JUMP MATH: PROHIBIDA LA REPRODUCCIÓN. EDICIÓN EN ESPAÑOL

Cuenta y rodea el número.

5.



1 2 3

6.

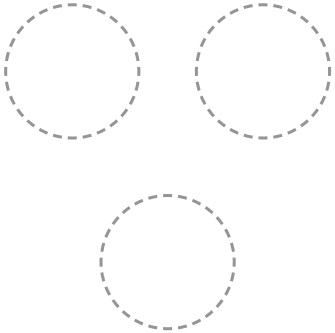

1 2 3

7.

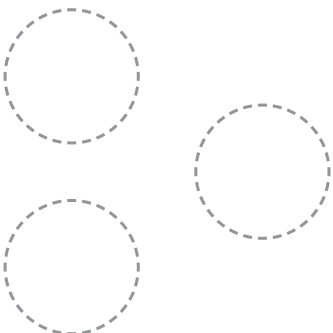

1 2 3

8.

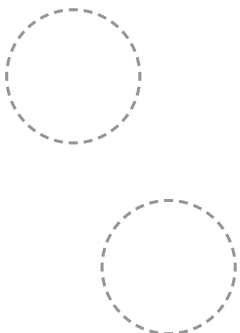

1 2 3

CCInf-6 Contar 1, 2 y 3 (ampliación)

Cuenta y tacha.

1.

3

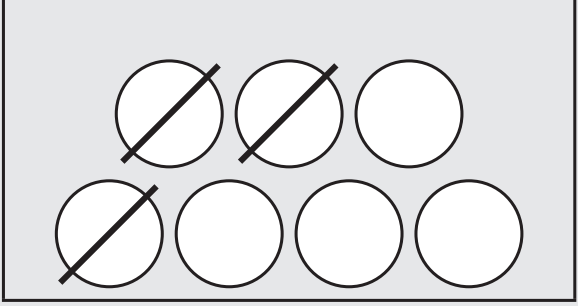

2.

1

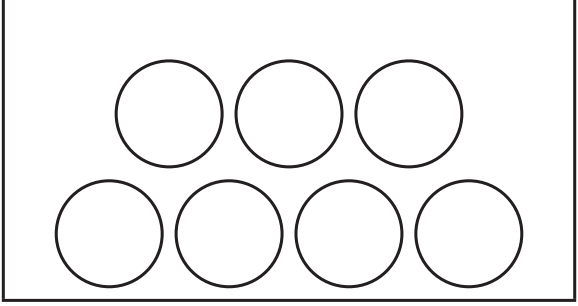

3.

2

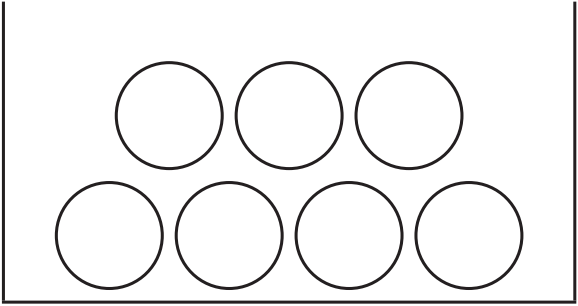

4.

3

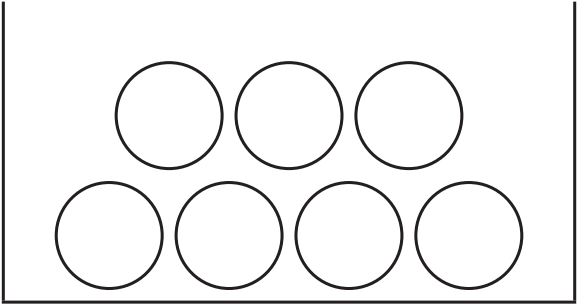

5.

1

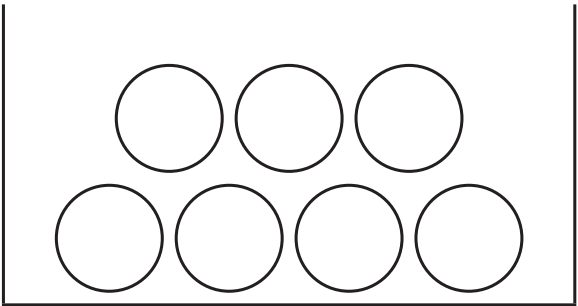

6.

2

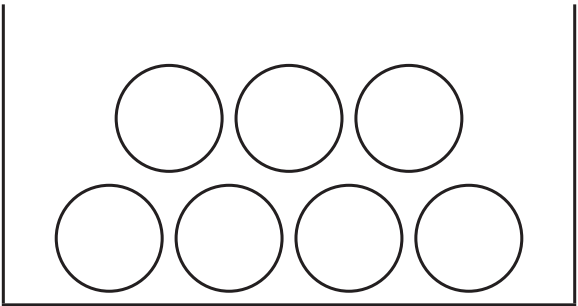

COPYRIGHT © 2017 JUMP MATH: PROHIBIDA LA REPRODUCCIÓN. EDICIÓN EN ESPAÑOL

EXTRA: Cuenta y tacha.

7.

3

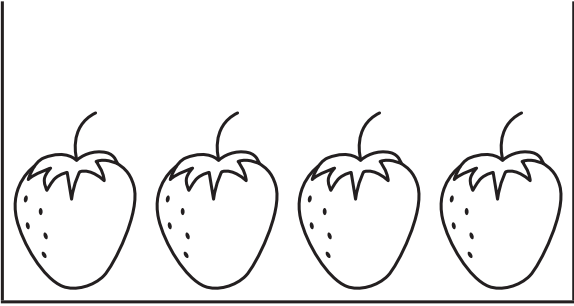

8.

2

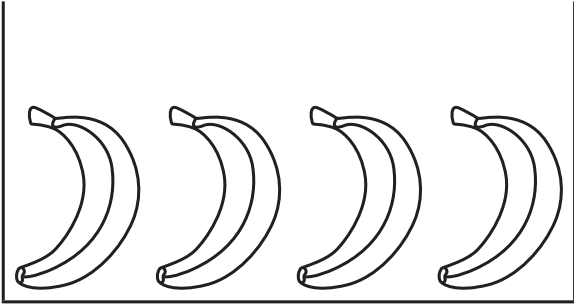

9.

1

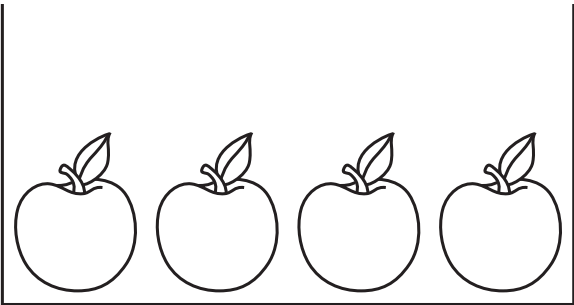

10.

3

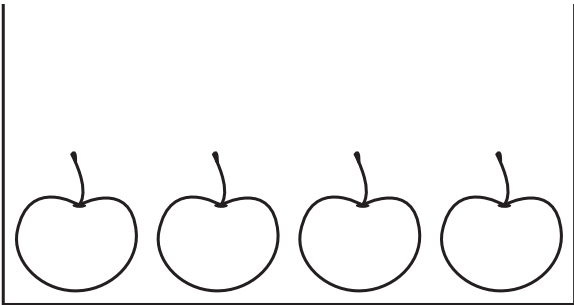

11.

2

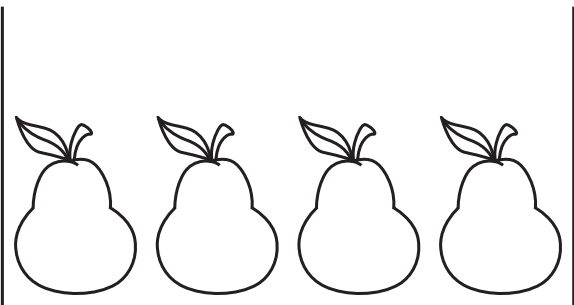

12.

1

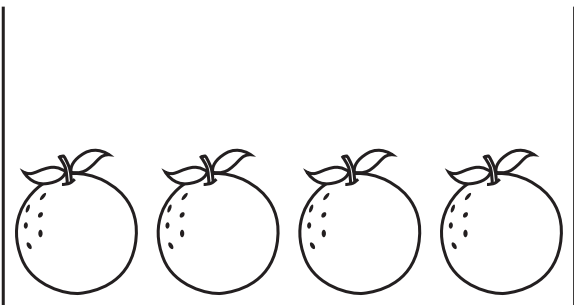

CCInf-7 Escribir el 1, el 2 y el 3

Repasa.

1.

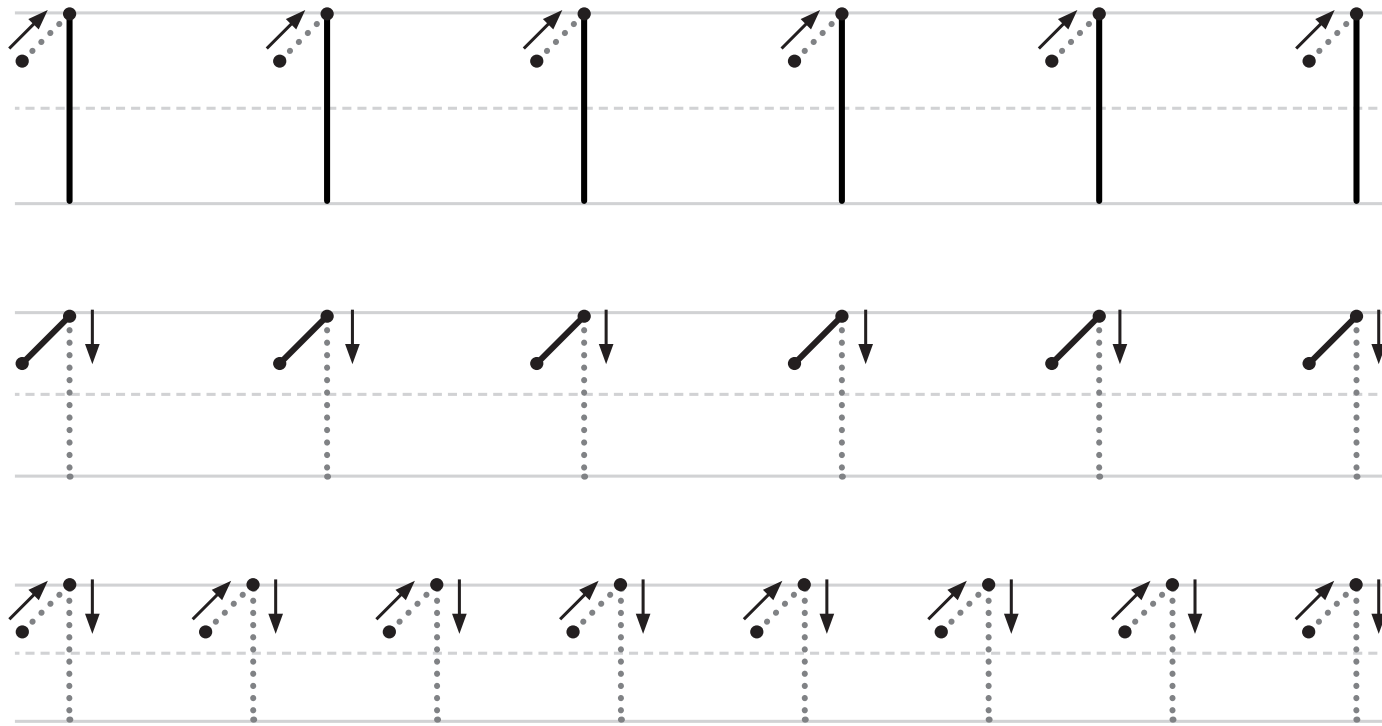

2.

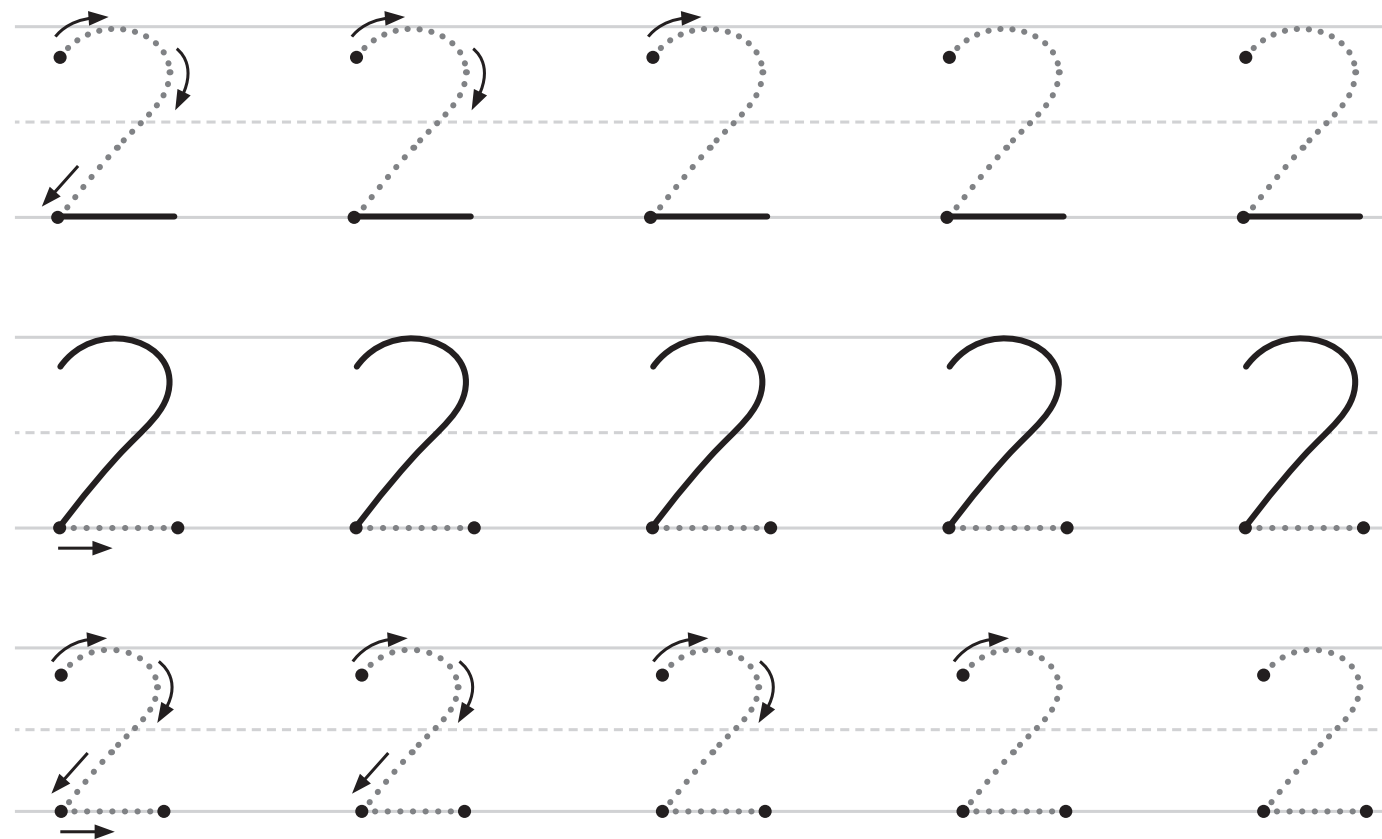

COPYRIGHT © 2017 JUMP MATH: PROHIBIDA LA REPRODUCCIÓN. EDICIÓN EN ESPAÑOL

Repasa.

3.

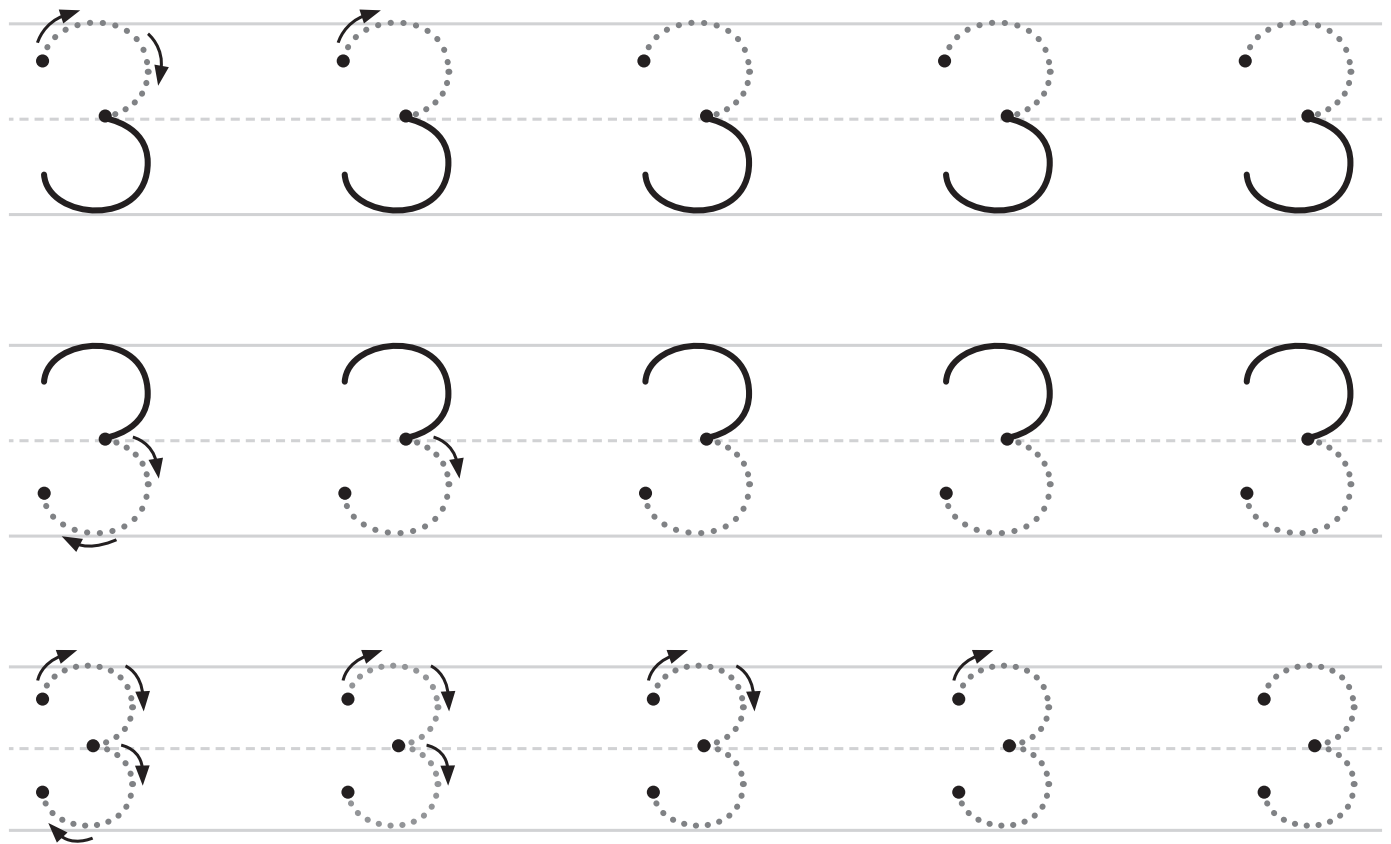

4.

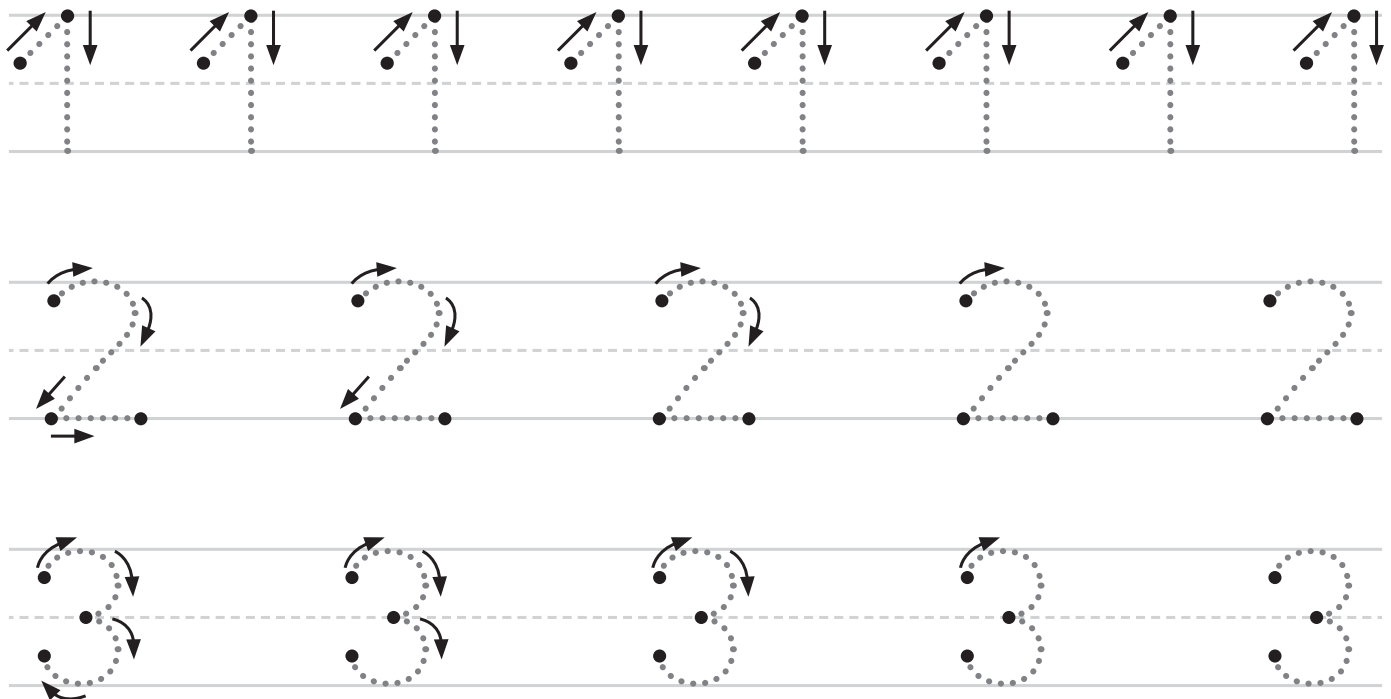

Repasa y colorea.

5.

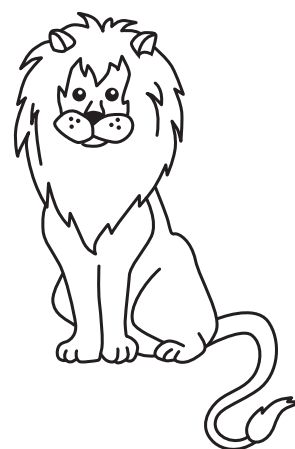
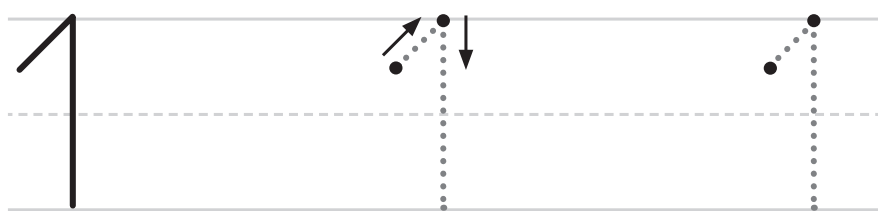

6.

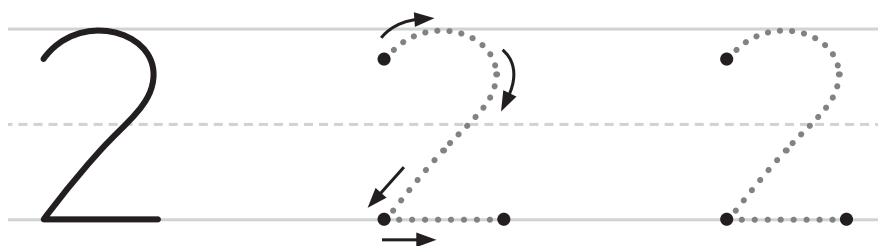

7.

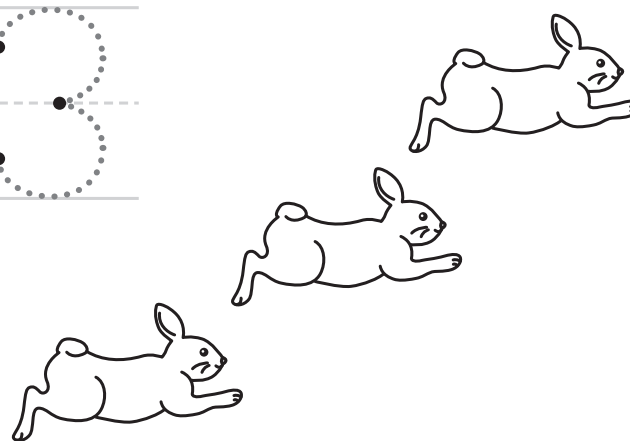
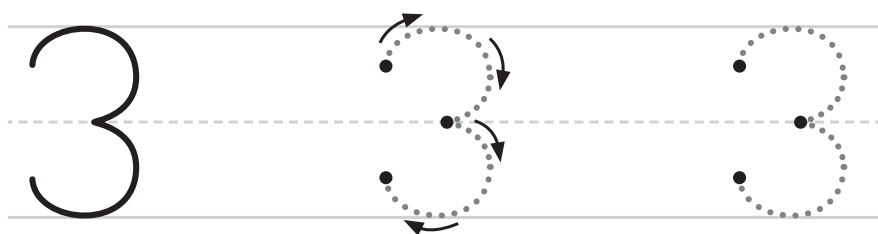

COPYRIGHT © 2017 JUMP MATH: PROHIBIDA LA REPRODUCCIÓN. EDICIÓN EN ESPAÑOL

CCInf-8 Contar 4

Usa . Cuenta.

1.



1 2 3 4

2.

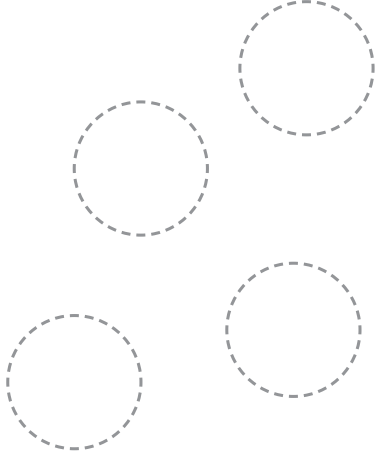

1 2 3 4

3.

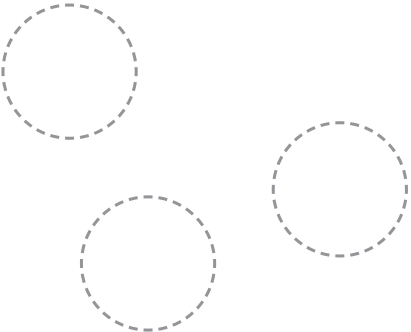

1 2 3 4

4.

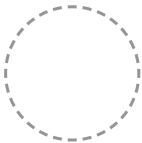

1 2 3 4

COPYRIGHT © 2017 JUMP MATH: PROHIBIDA LA REPRODUCCIÓN. EDICIÓN EN ESPAÑOL

Cuenta y tacha.

5. **4**

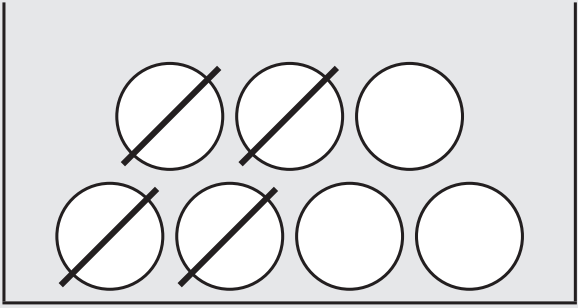

6. **2**

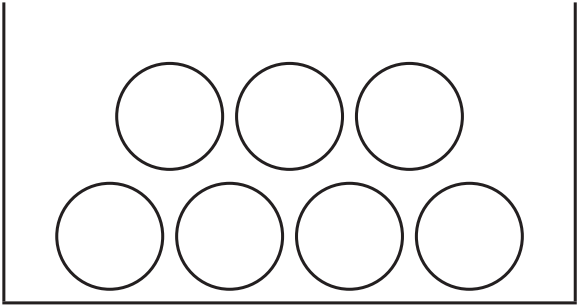

7. **1**

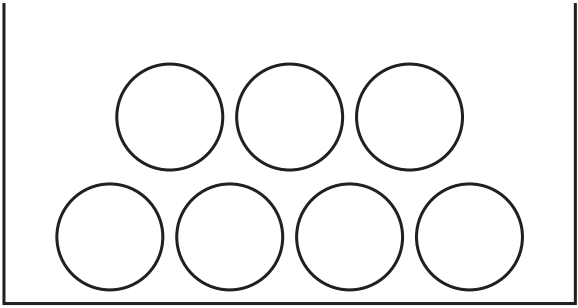

8. **3**

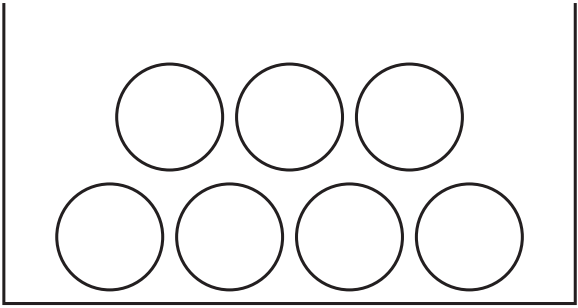

9. **3**

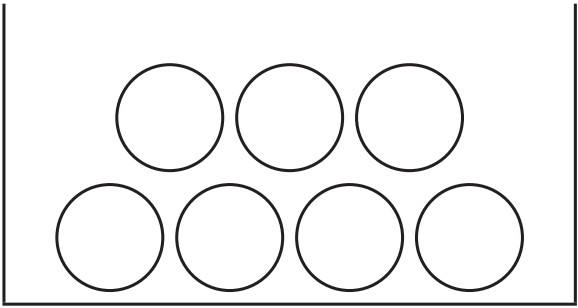

10. **4**

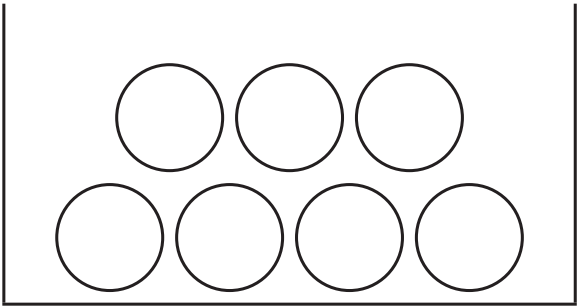

COPYRIGHT © 2017 JUMP MATH: PROHIBIDA LA REPRODUCCIÓN. EDICIÓN EN ESPAÑOL

EXTRA: Cuenta y tacha.

11.

3



12.

2

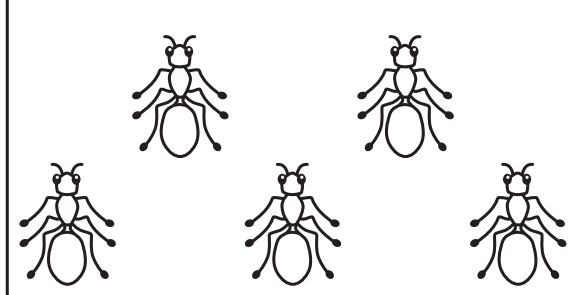

13.

4

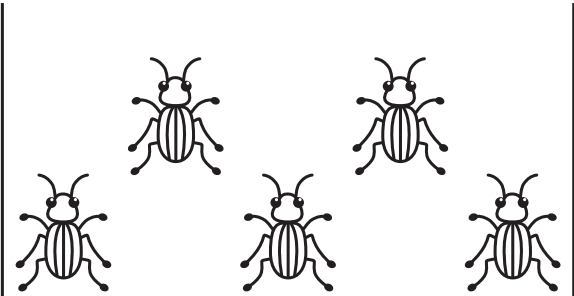

14.

1

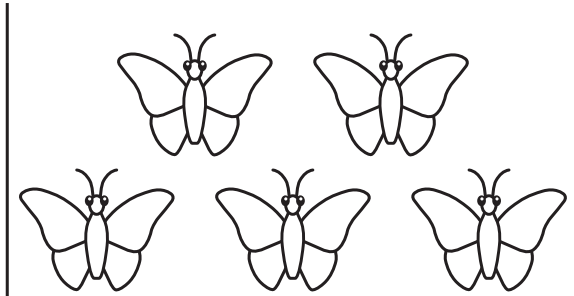

15.

3

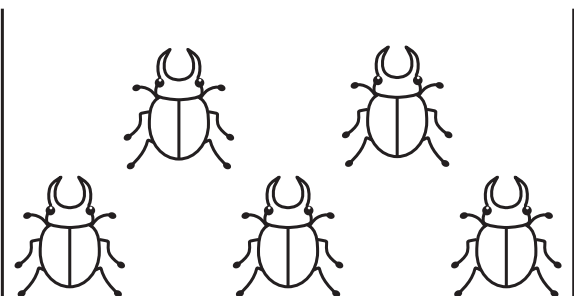

16.

4

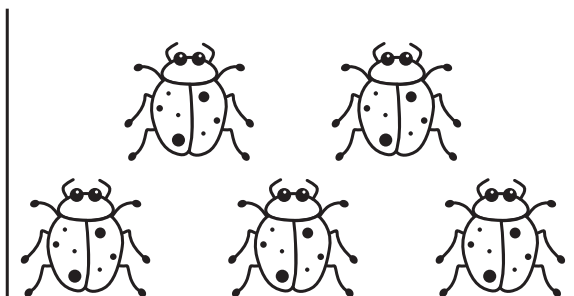

COPYRIGHT © 2017 JUMP MATH: PROHIBIDA LA REPRODUCCIÓN. EDICIÓN EN ESPAÑOL.

CCInf-9 El número 4

Pega el número 3 o 4.

1.

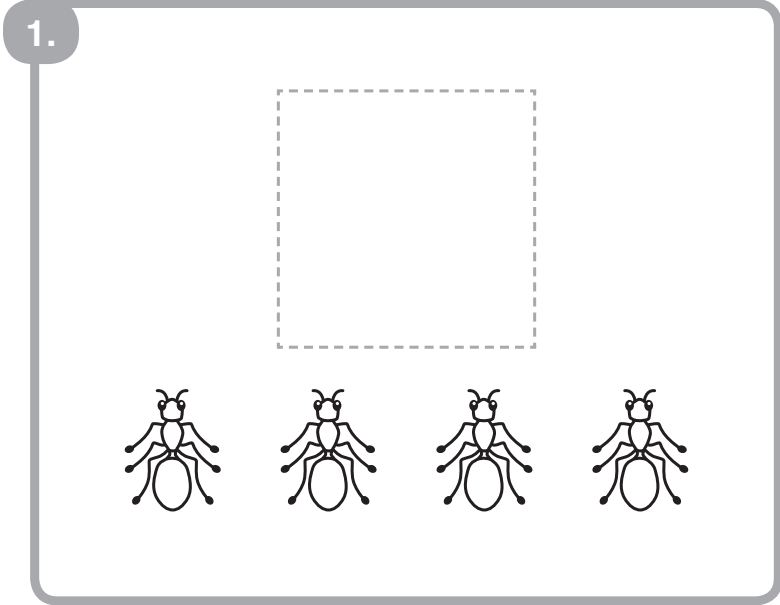

2.

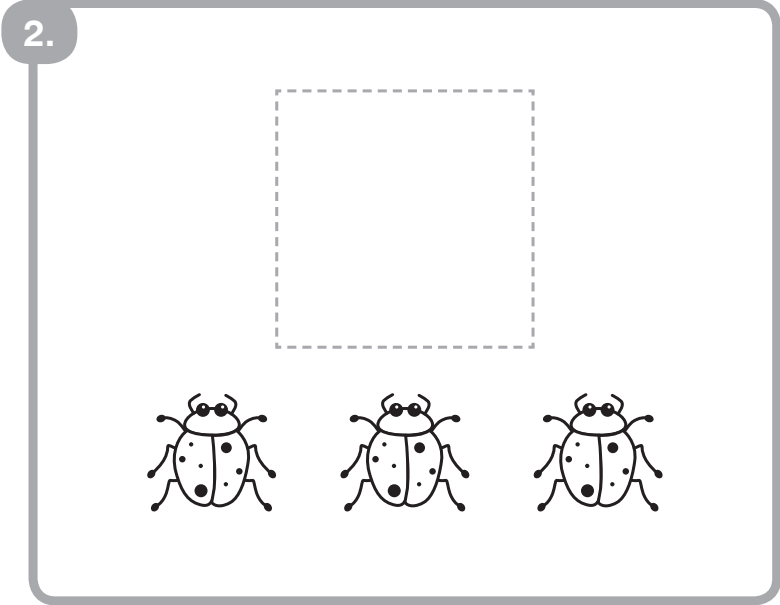

3.

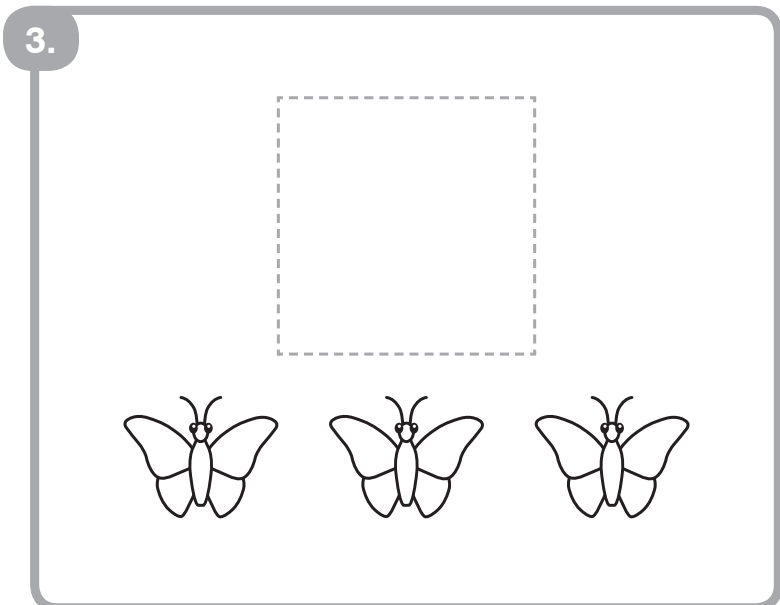

4.

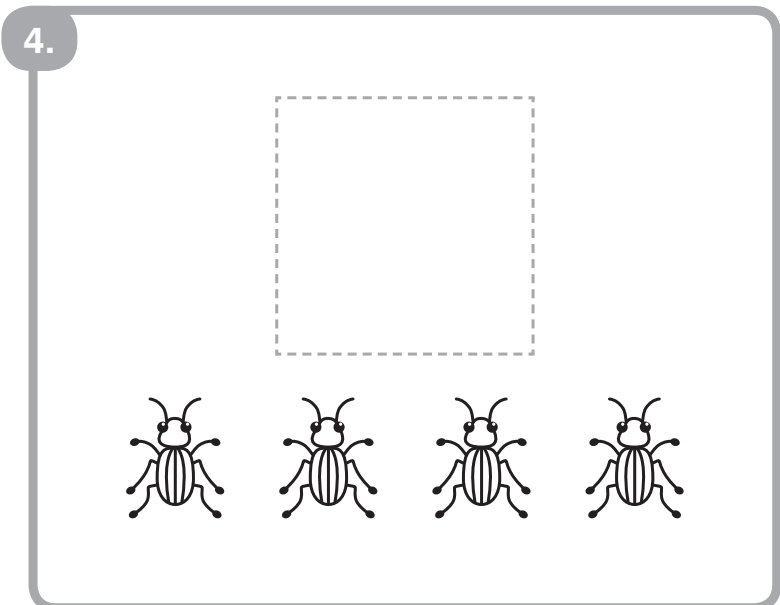

5.

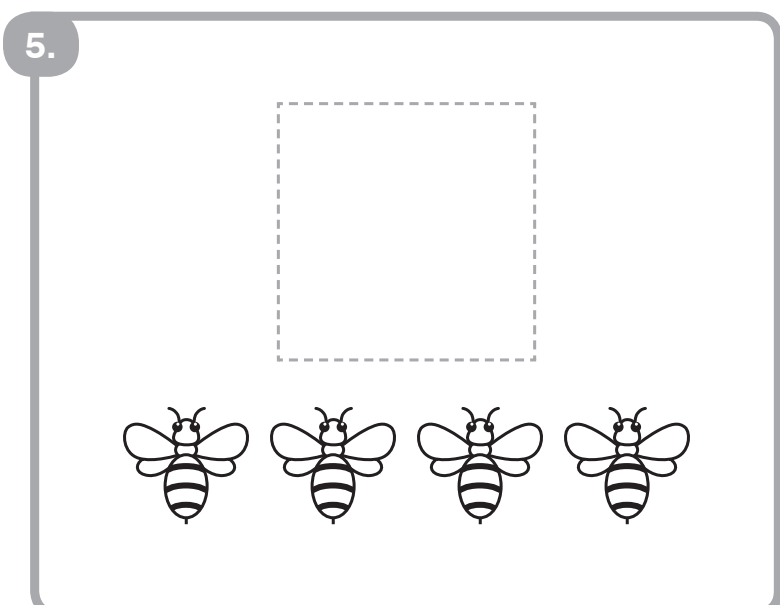

6.

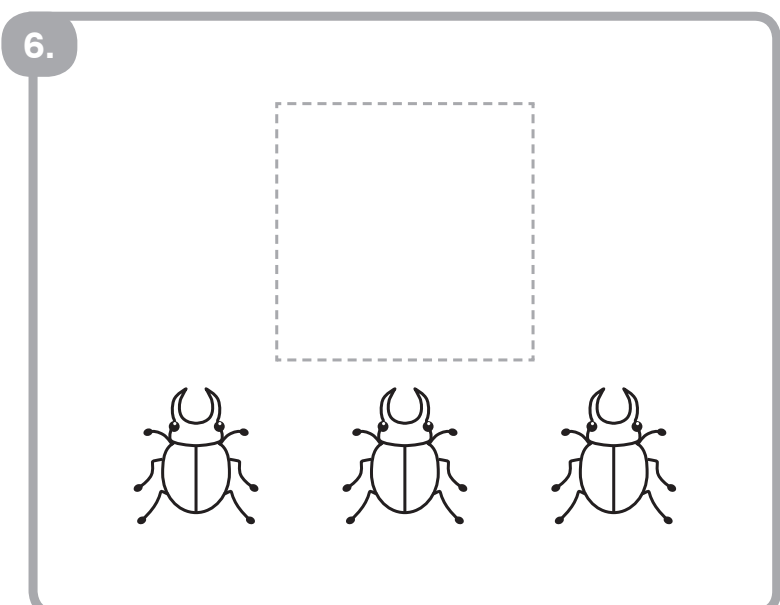

COPYRIGHT © 2017 JUMP MATH: PROHIBIDA LA REPRODUCCIÓN. EDICIÓN EN ESPAÑOL

Pega el número 1, 2, 3 o 4.

7.

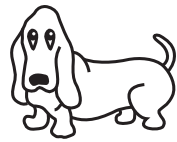

8.

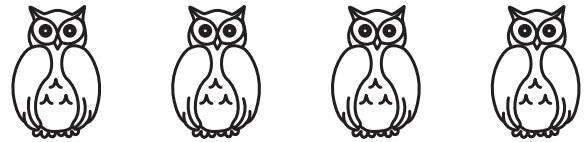

9.

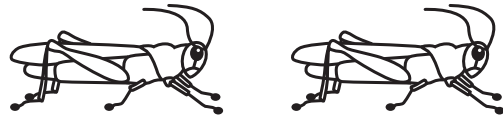

10.

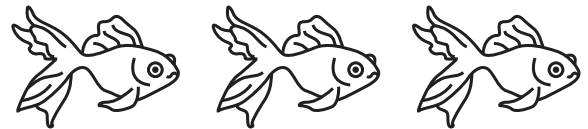

11.

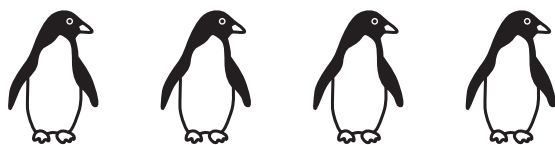

12.

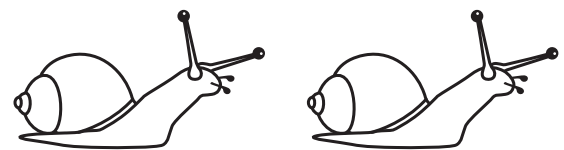

Pega un dibujo de 1, 2, 3 o 4.

13.

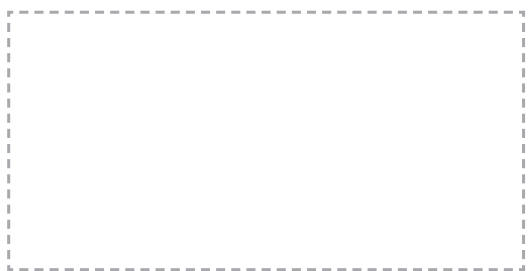

3

14.



1

15.

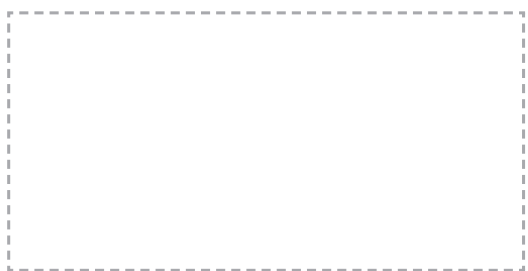

2

16.

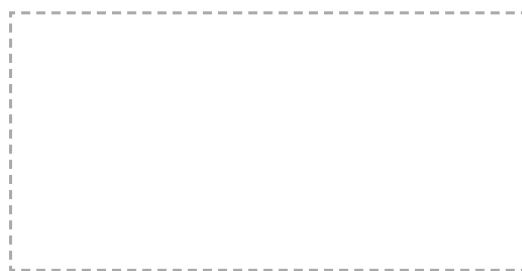

4

17.

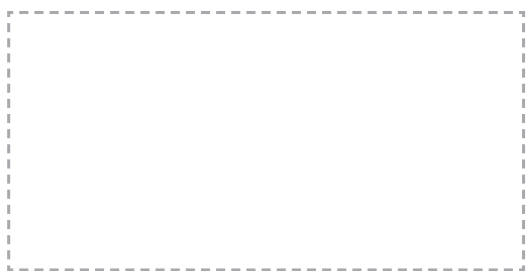

4

18.





3

EXTRA: Colorea 😊 si es correcto. Colorea ☹ si no es correcto.

19.





4

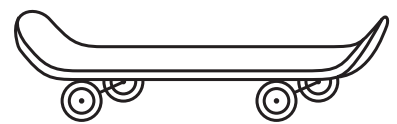

20.





2

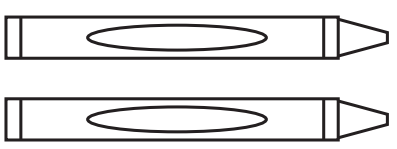

21.





1

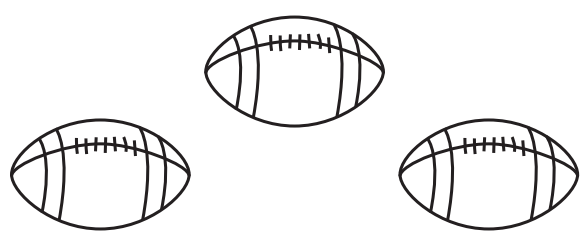

22.





3



23.





2



24.



4



CCInf-10 Escribir el 4

Repasa.

1.

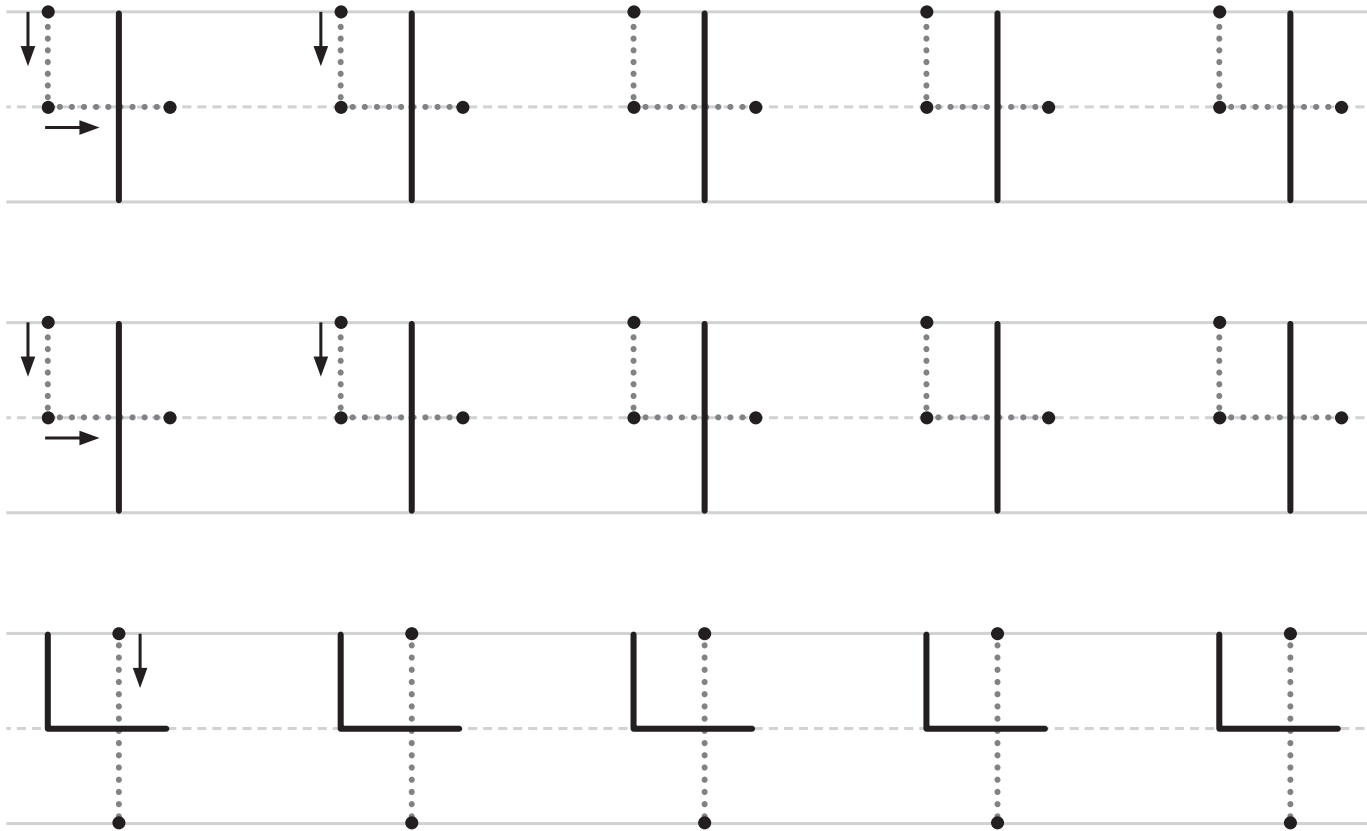

2.

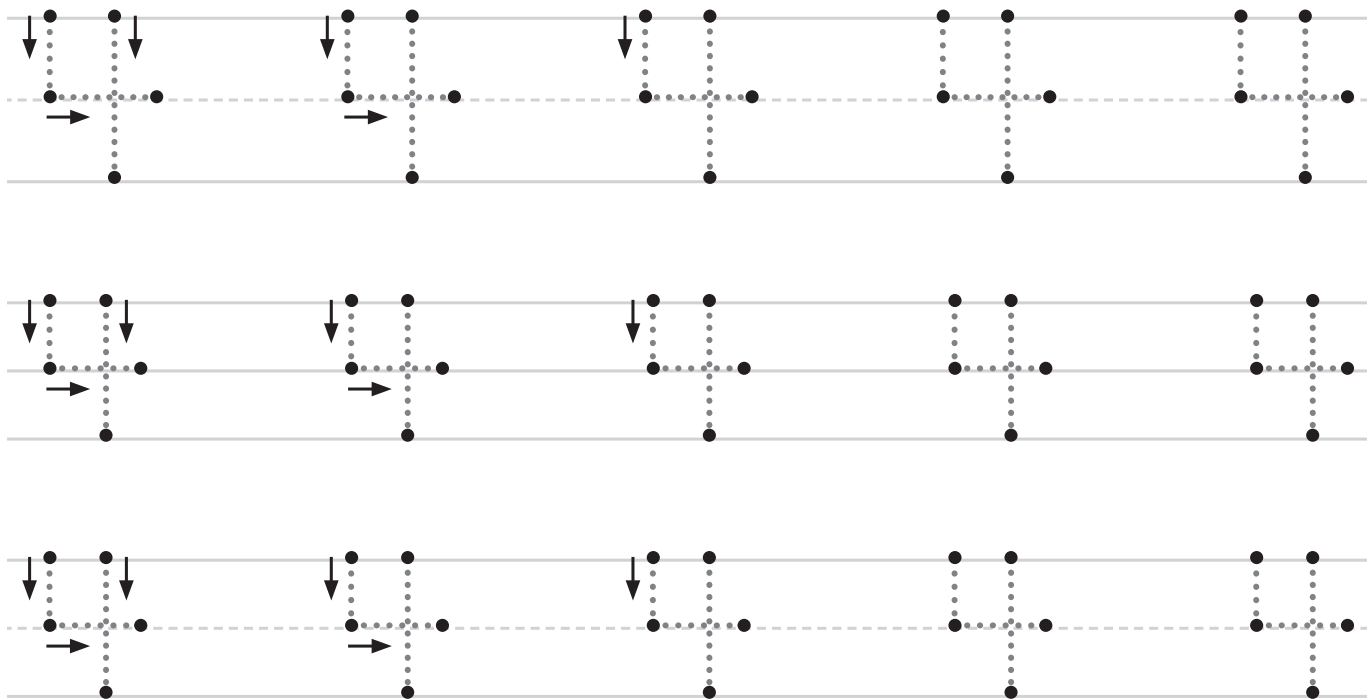

Repasa y colorea.

3.

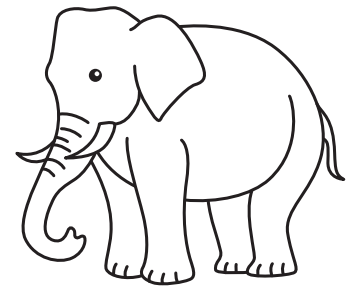
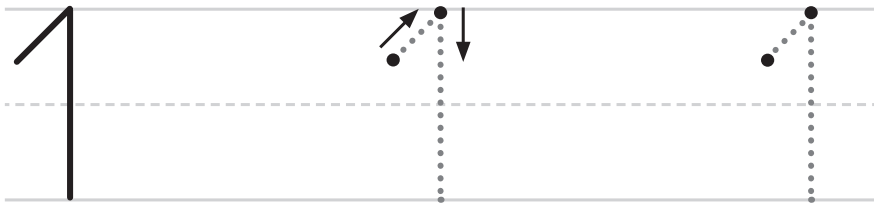

4.

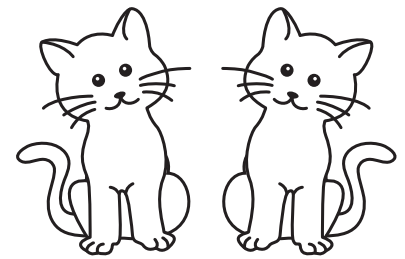
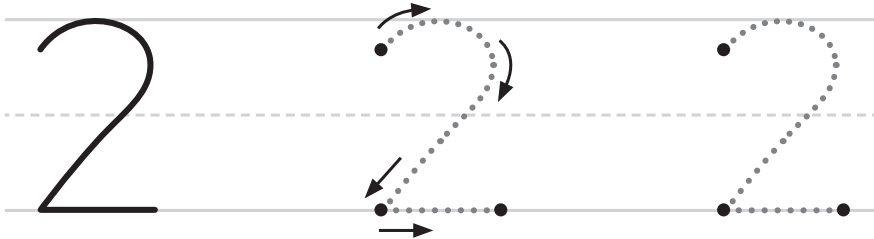

5.

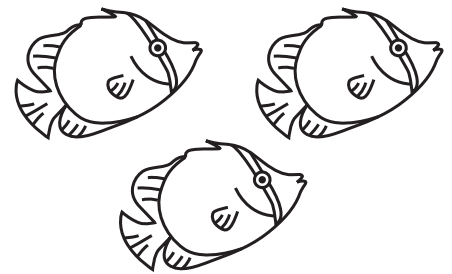
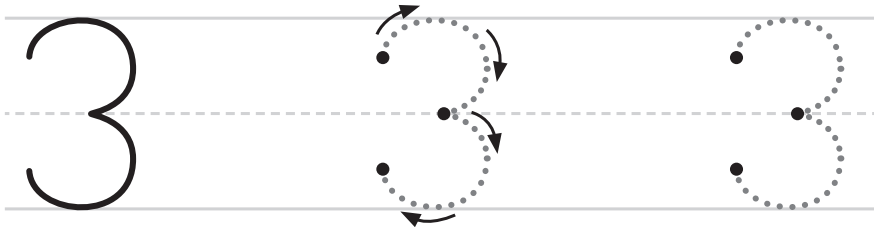

6.

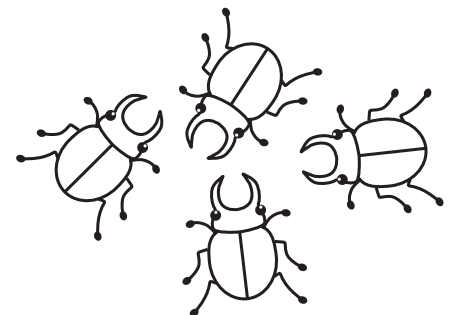
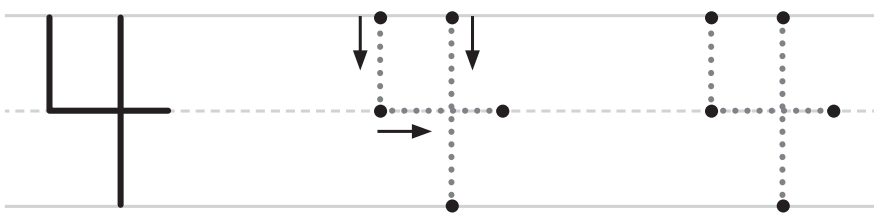

CCInf-11 Contar 5

Cuenta y rodea el número.

1.



1 2 3 4 5

2.

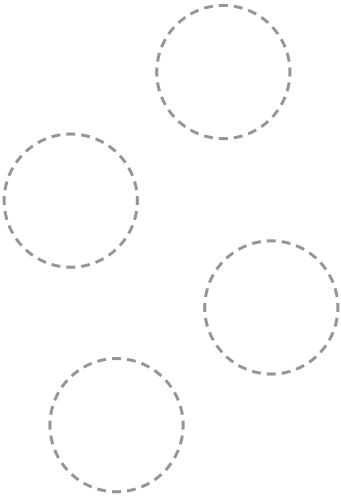

1 2 3 4 5

3.

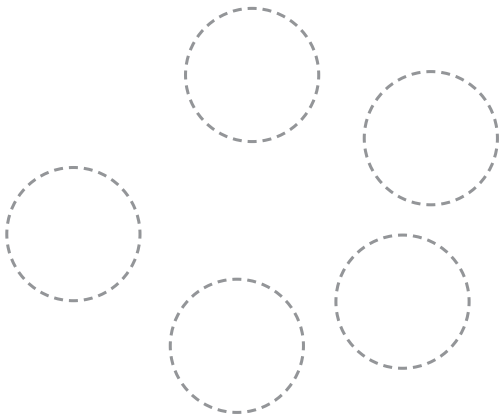

1 2 3 4 5

4.



1 2 3 4 5

COPYRIGHT © 2017 JUMP MATH: PROHIBIDA LA REPRODUCCIÓN. EDICIÓN EN ESPAÑOL

Cuenta y rodea el número.

5.

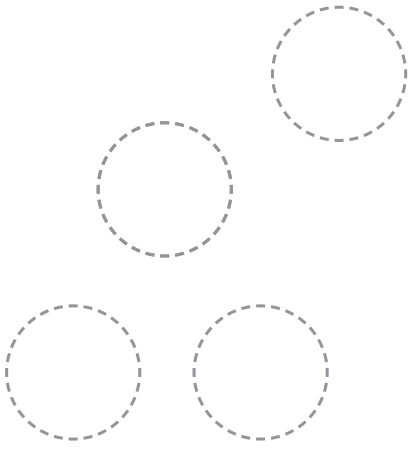

1 2 3 4 5

6.



1 2 3 4 5

7.

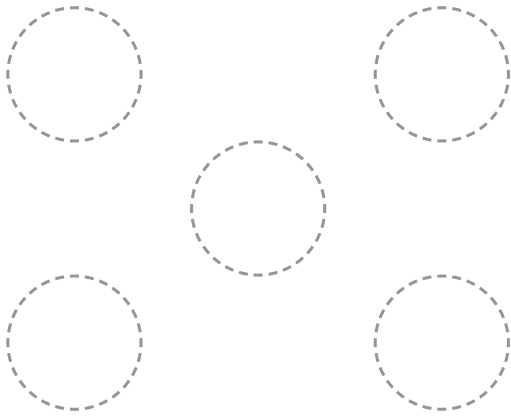

1 2 3 4 5

8.

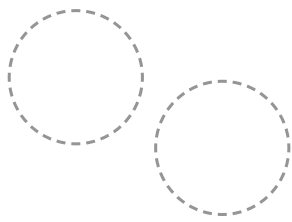

1 2 3 4 5

Cuenta y rodea el número.

9.

3

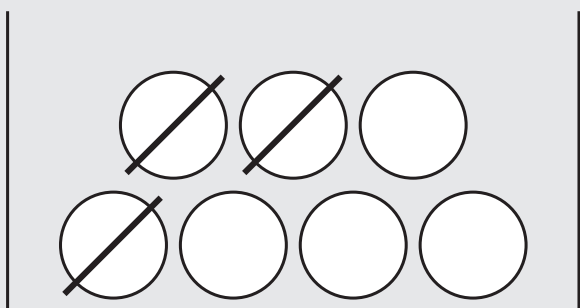

10.

5

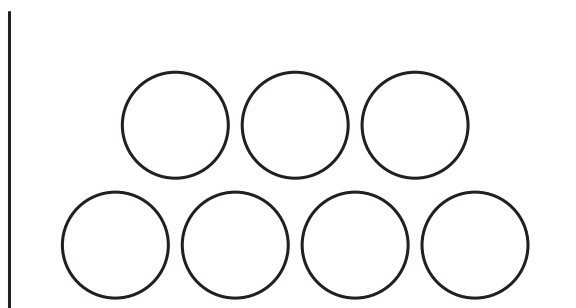

11.

2

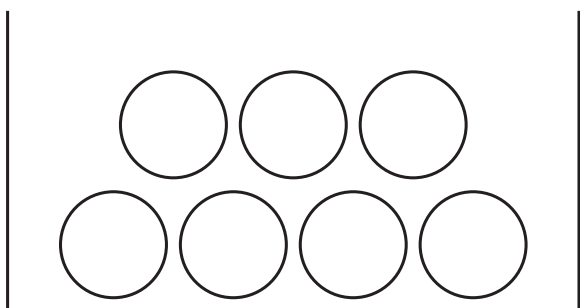

12.

4

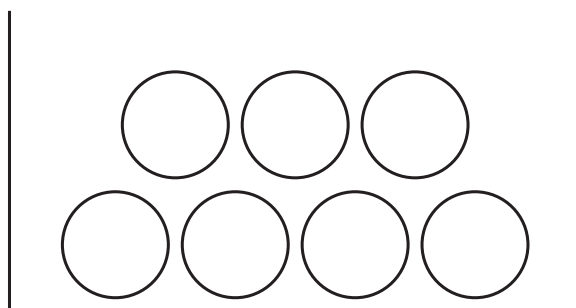

13.

5

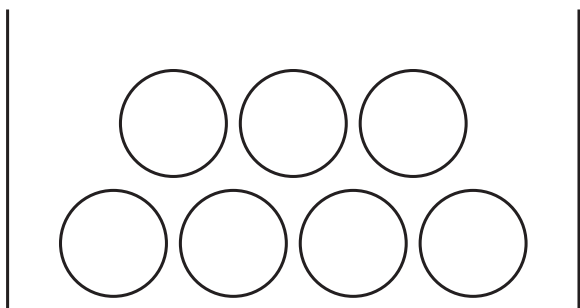

14.

1

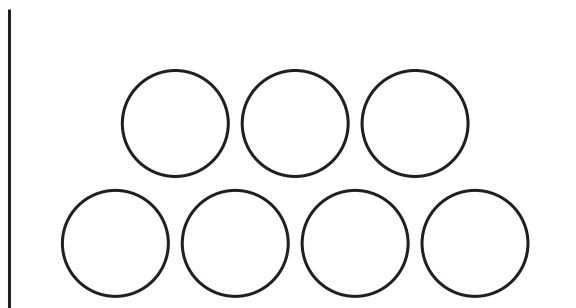

EXTRA: Cuenta y tacha.

15.

4

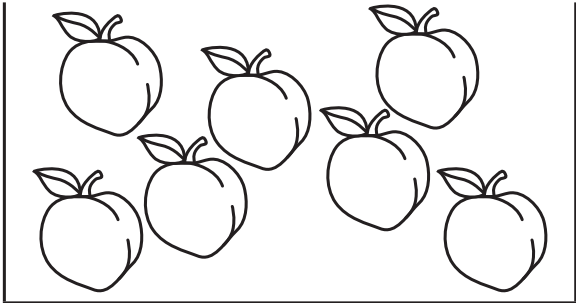

16.

3

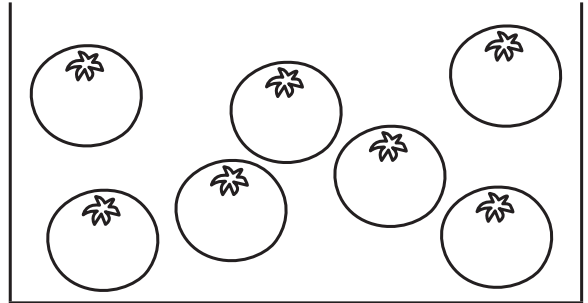

17.

5

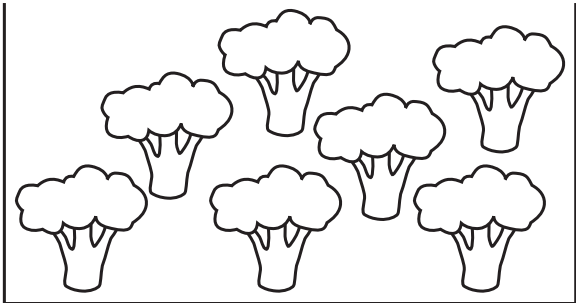

18.

2

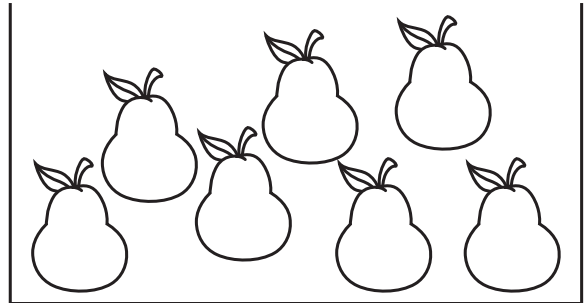

19.

3

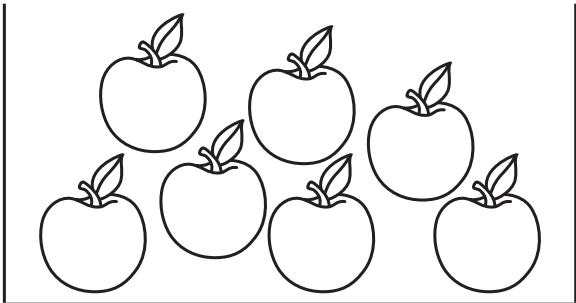

20.

5

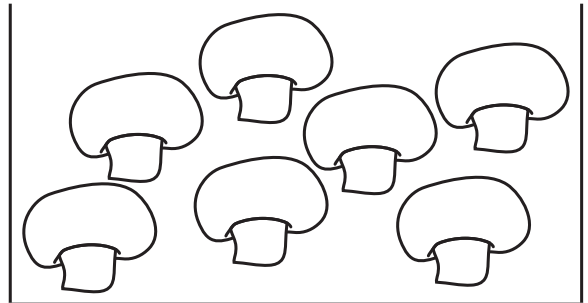

CCInf-12 El número 5

Pega el número 1, 2, 3, 4 o 5.

1.

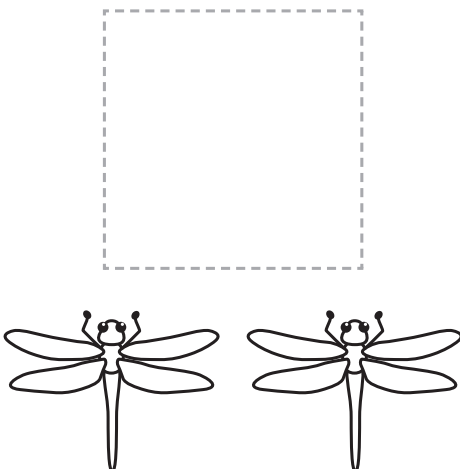

2.

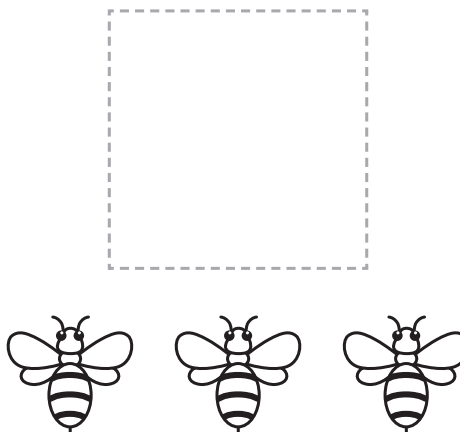

3.

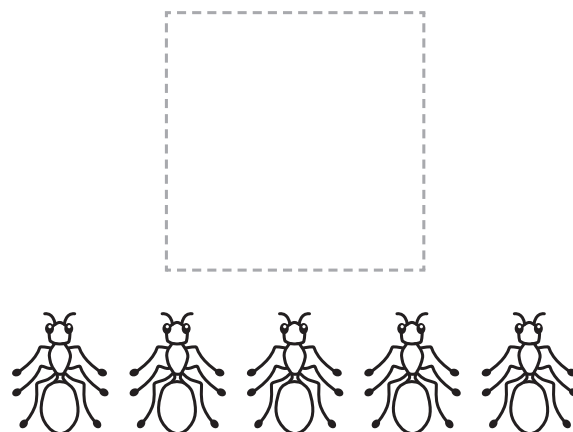

4.

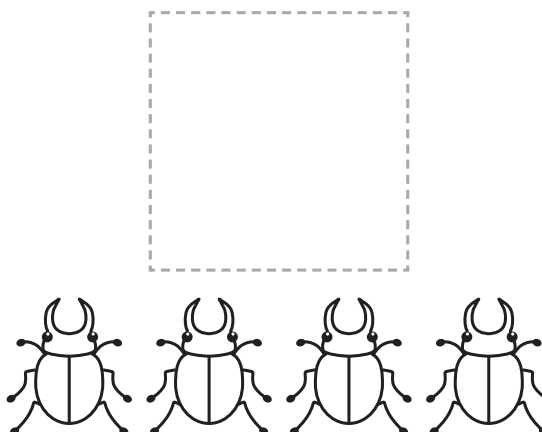

5.

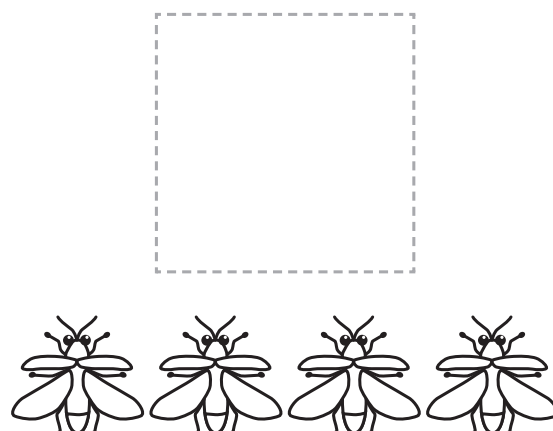

6.

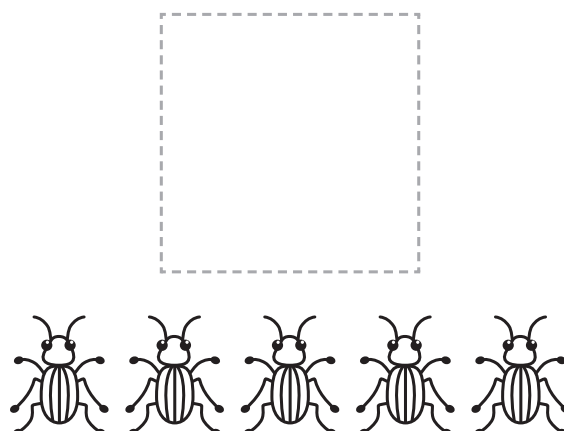

COPYRIGHT © 2017 JUMP MATH: PROHIBIDA LA REPRODUCCIÓN. EDICIÓN EN ESPAÑOL

Pega un dibujo de 1, 2, 3, 4 o 5.

7.



3

8.



2

9.



5

10.



4

11.



1

12.



5

EXTRA: Colorea 😊 si es correcto. Colorea ☹ si no es correcto.

13.

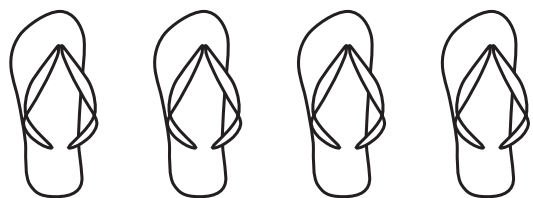

5



14.

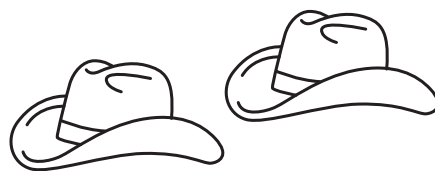

2



15.

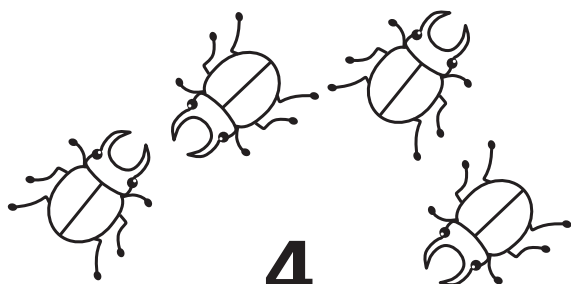

4



16.



3



17.

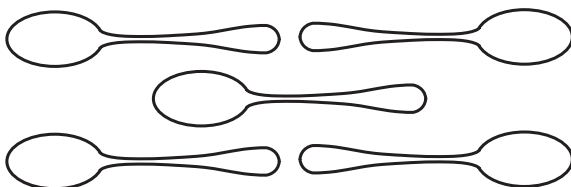

5



18.



1



CCInf-13 Escribir el 5

Repasa.

1.

Handwriting practice for the number 5. The first row shows five examples of the number 5 with arrows indicating the stroke order: a horizontal line from left to right, a vertical line down, and a curved line from the top of the vertical line to the bottom. The second row shows five more examples with stroke order arrows. The third row shows five dotted 5s with stroke order arrows. The fourth row shows five dotted 5s with stroke order arrows.

2.

Handwriting practice for the number 5. The first row shows five dotted 5s with stroke order arrows. The second row shows five dotted 5s with stroke order arrows.

Repasa y colorea.

3.

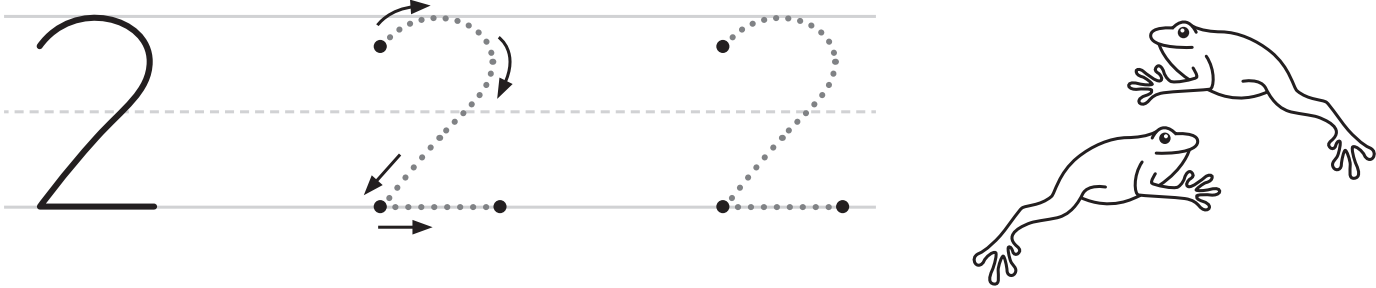

4.

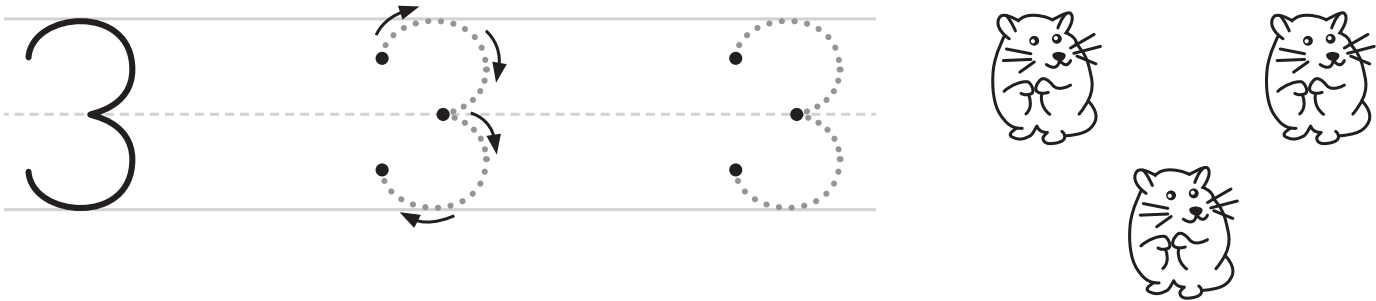

5.



6.

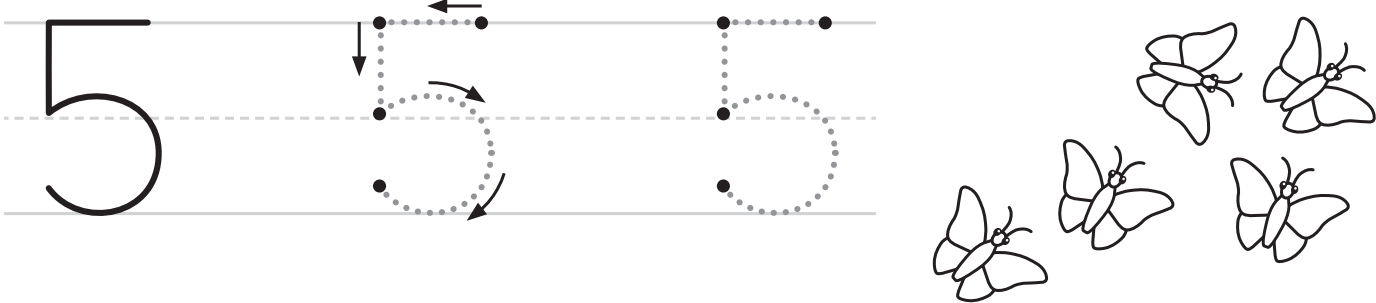

COPYRIGHT © 2017 JUMP MATH: PROHIBIDA LA REPRODUCCIÓN. EDICIÓN EN ESPAÑOL

CCInf-14 Repaso de 1, 2, 3, 4 y 5

Colorea.

1.

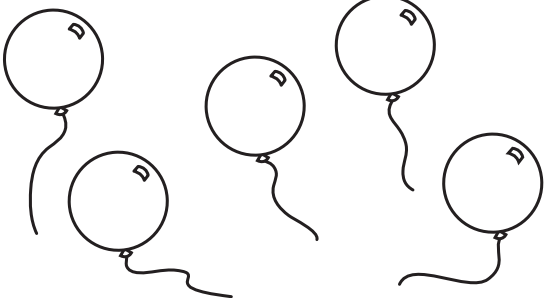

1

A square box containing a single balloon with a string and a small bow. The number '1' is printed below the balloon.

2.

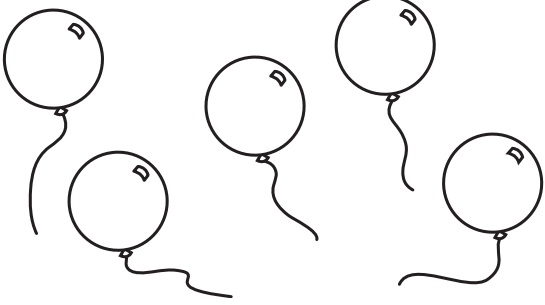

2

A square box containing two balloons, one on the left and one on the right, each with a string and a small bow. The number '2' is printed below the balloons.

3.

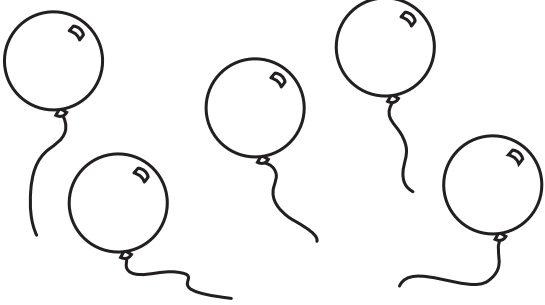

3

A square box containing three balloons arranged in a row, each with a string and a small bow. The number '3' is printed below the balloons.

4.

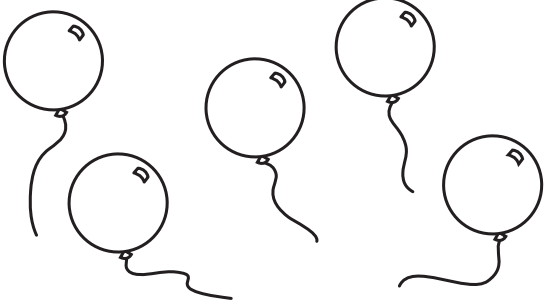

4

A square box containing four balloons arranged in two rows of two, each with a string and a small bow. The number '4' is printed below the balloons.

5.

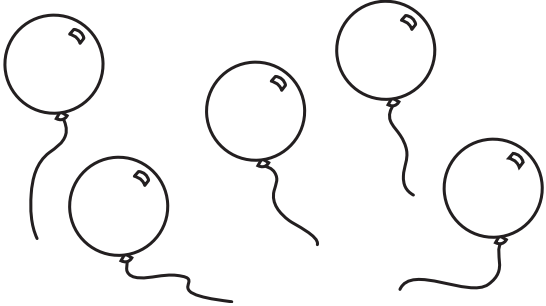

5

A square box containing five balloons arranged in two rows: three in the top row and two in the bottom row, each with a string and a small bow. The number '5' is printed below the balloons.

Colorea.

6.

1

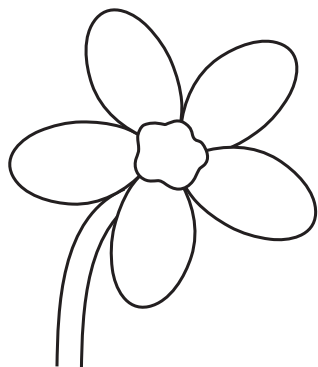

7.

2

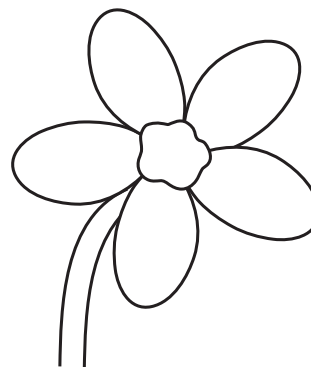

8.

3

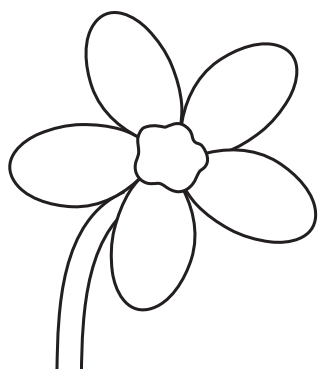

9.

4

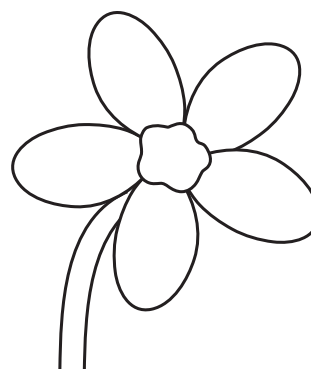

10.

5

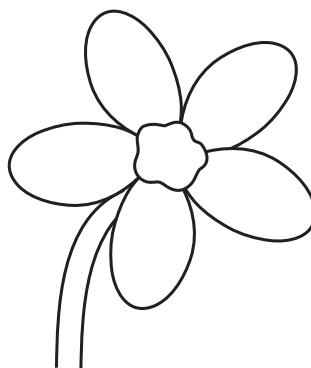

CCInf-15 Contar hasta el 20

Repasa.

1.

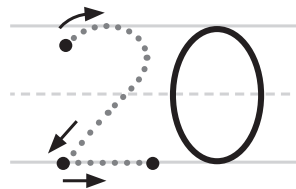
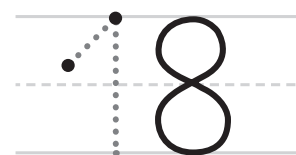
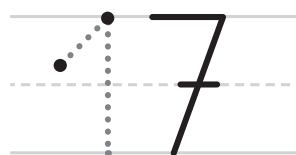
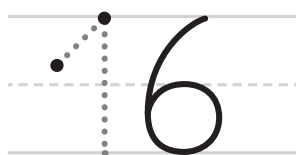
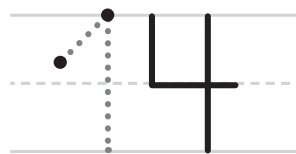
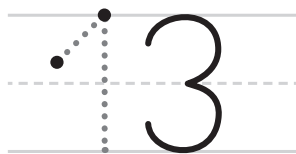
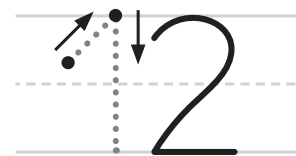
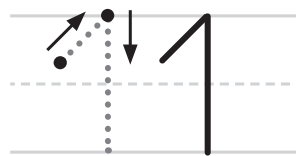
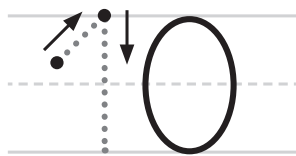

2.

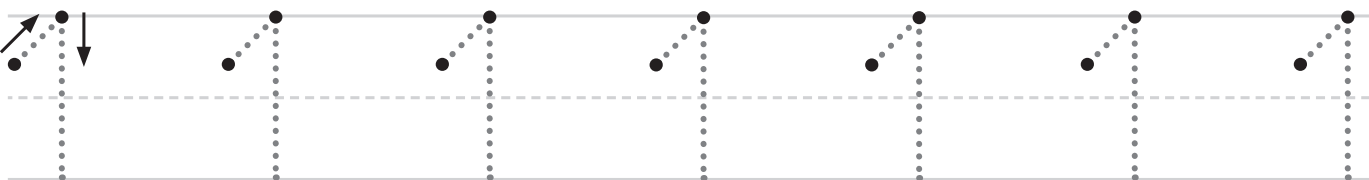

3.

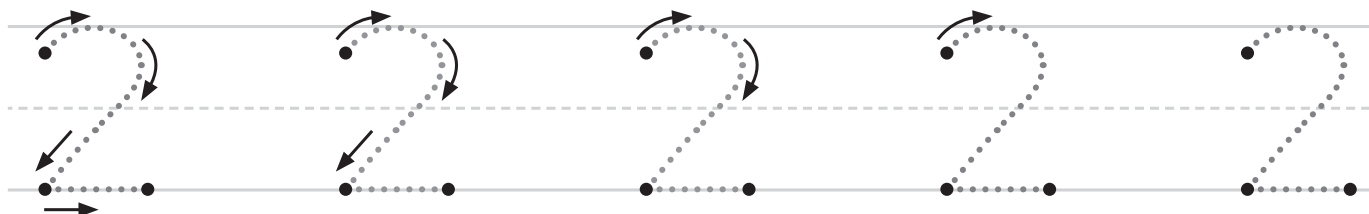

COPYRIGHT © 2017 JUMP MATH: PROHIBIDA LA REPRODUCCIÓN. EDICIÓN EN ESPAÑOL

Colorea el ☀ del grupo que tiene **más elementos**.

1.

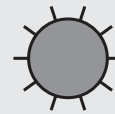
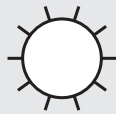
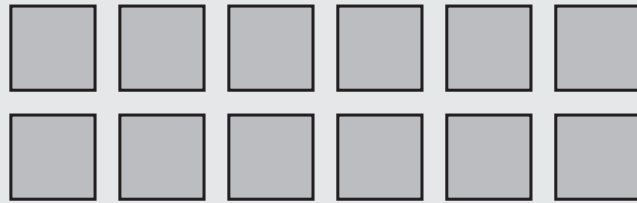

2.

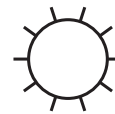
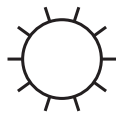
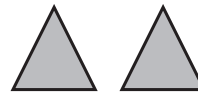
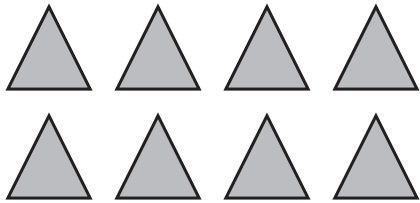

3.

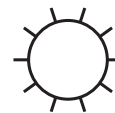
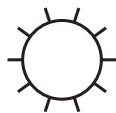
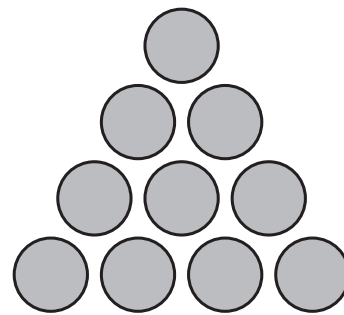
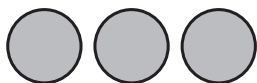

Colorea el ☀ del grupo que tiene **más elementos**.

4.

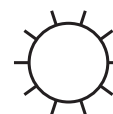
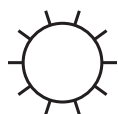
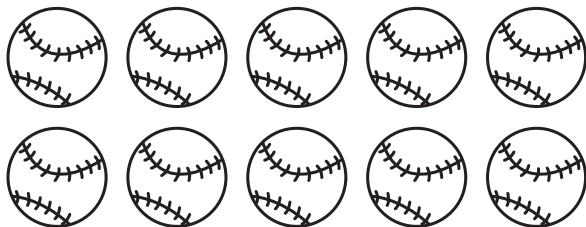

5.

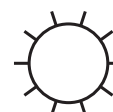
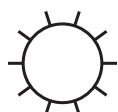
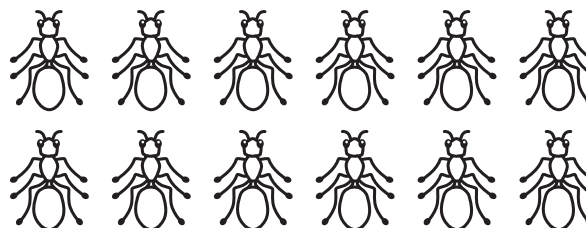
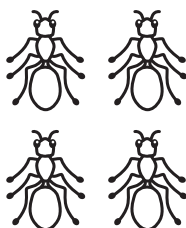

6.

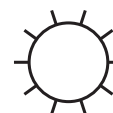
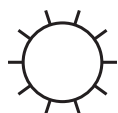
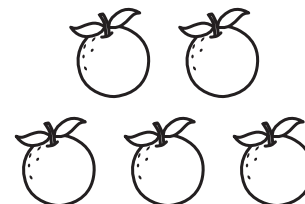
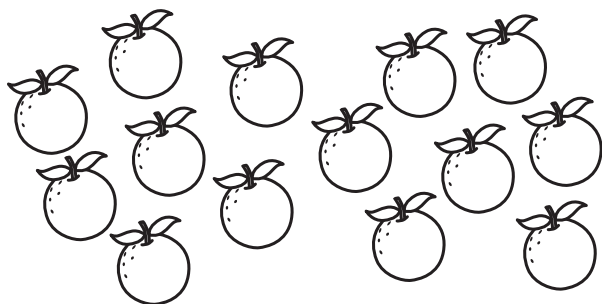

Une los puntos.

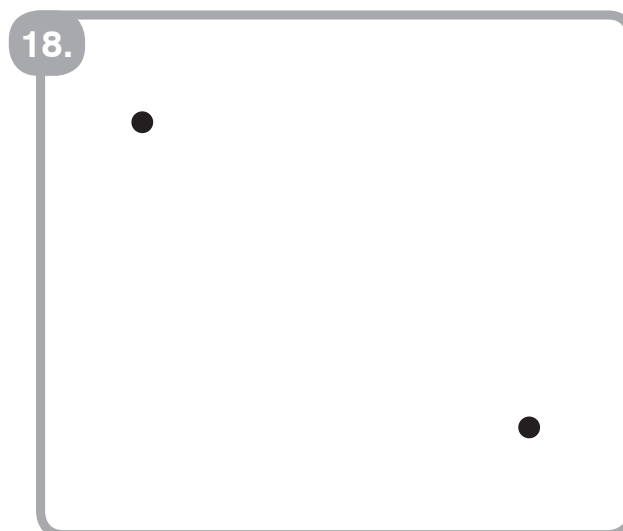
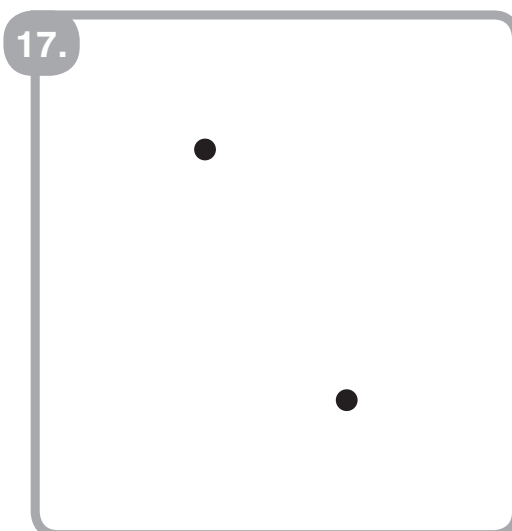
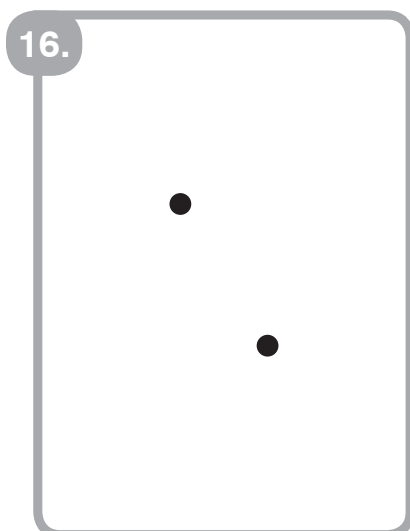
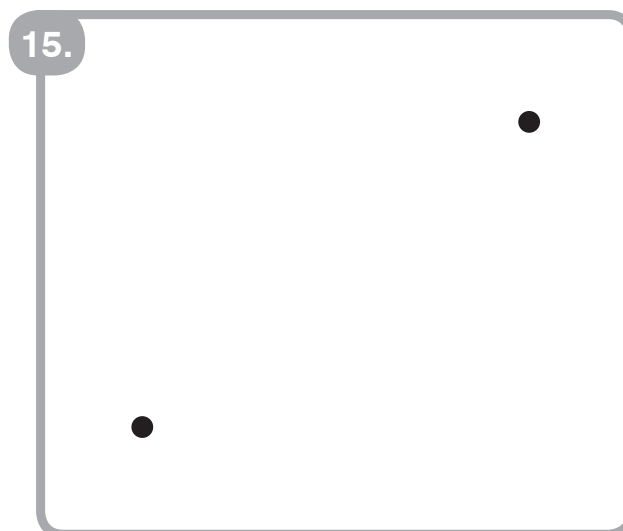
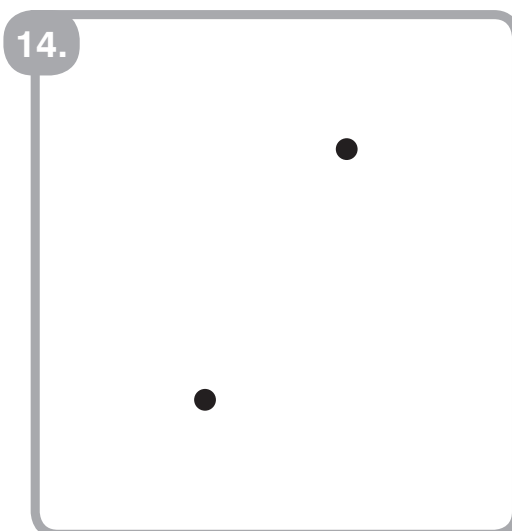
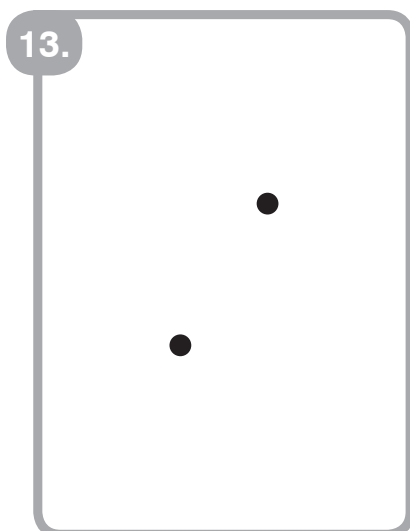
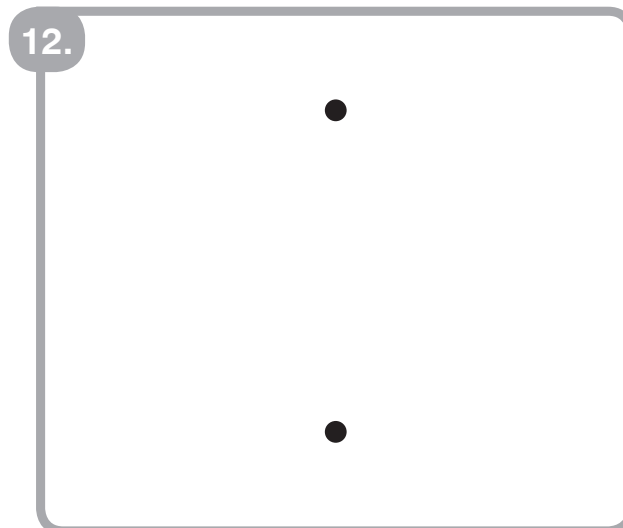
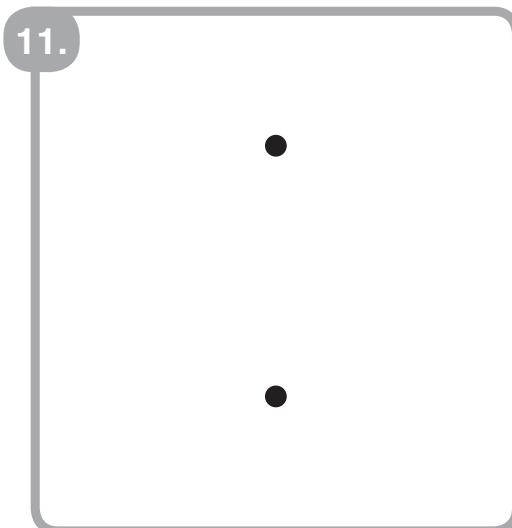
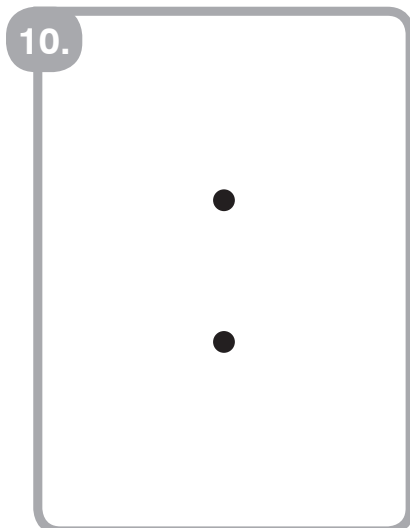
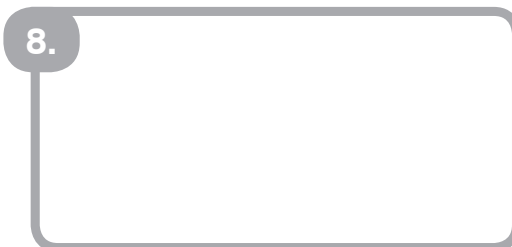
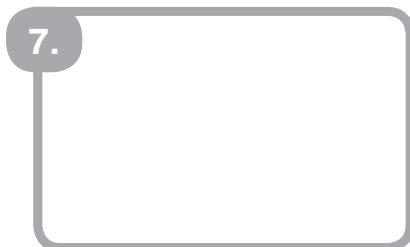

COPYRIGHT © 2017 JUMP MATH: PROHIBIDA LA REPRODUCCIÓN. EDICIÓN EN ESPAÑOL

Une los puntos.

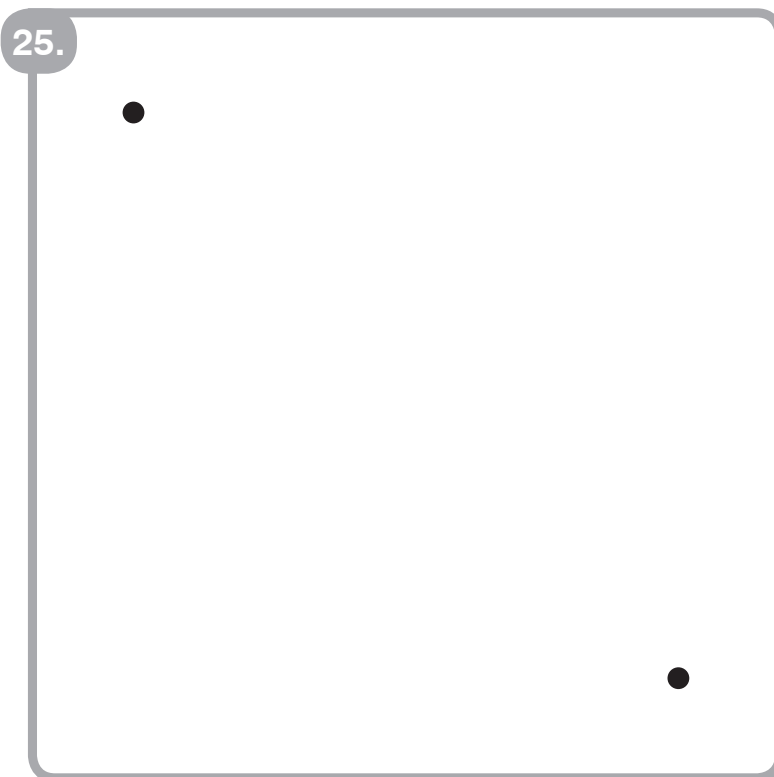
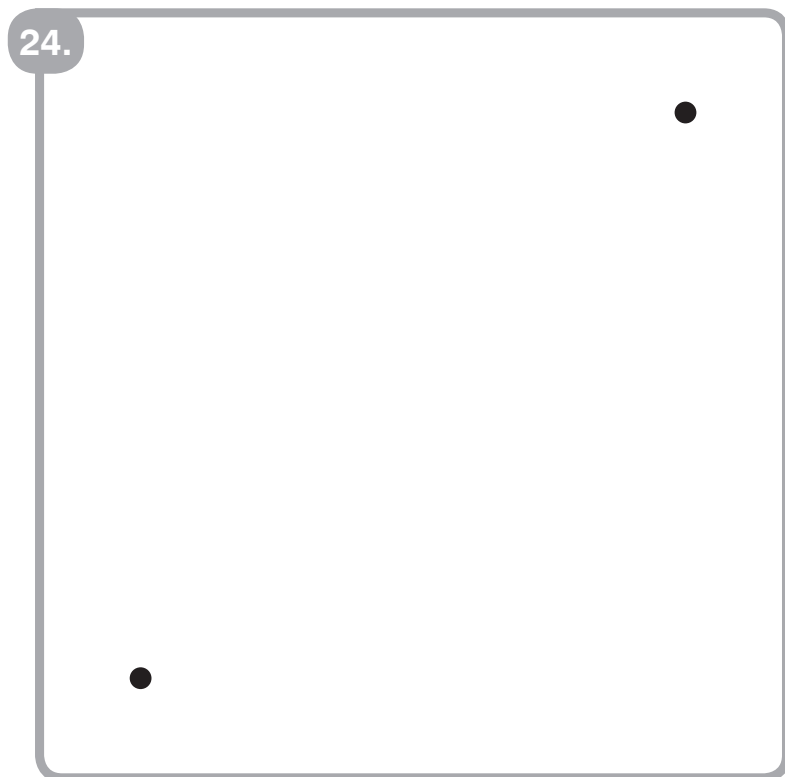
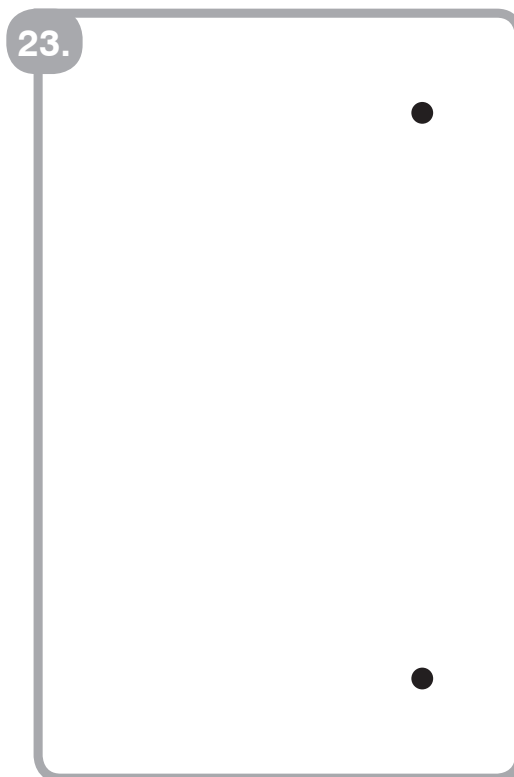
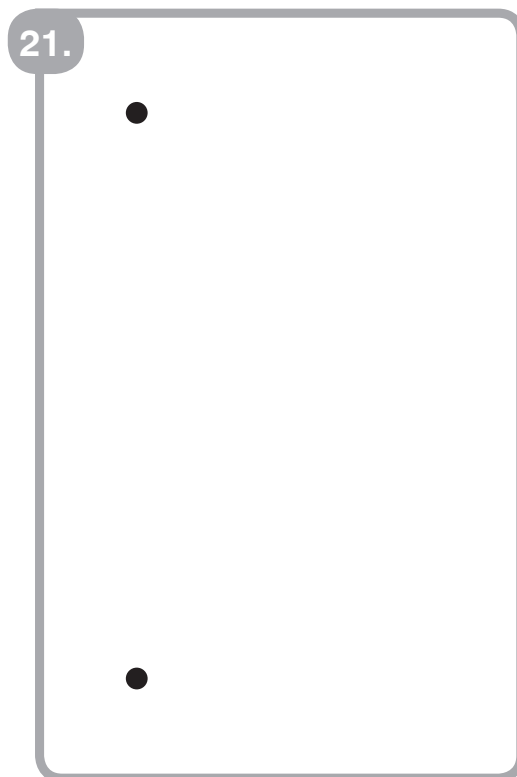
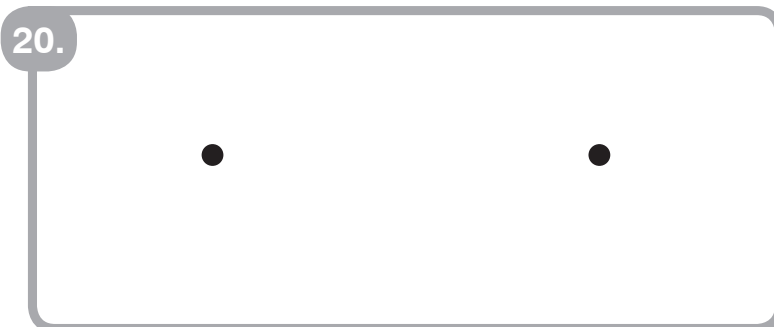
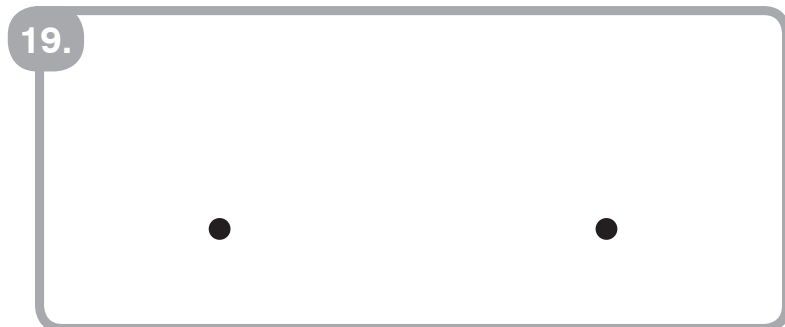

COPYRIGHT © 2017 JUMP MATH: PROHIBIDA LA REPRODUCCIÓN. EDICIÓN EN ESPAÑOL

CCInf-17 Igual a (relacionar)

Dibuja una  en cada .

1.

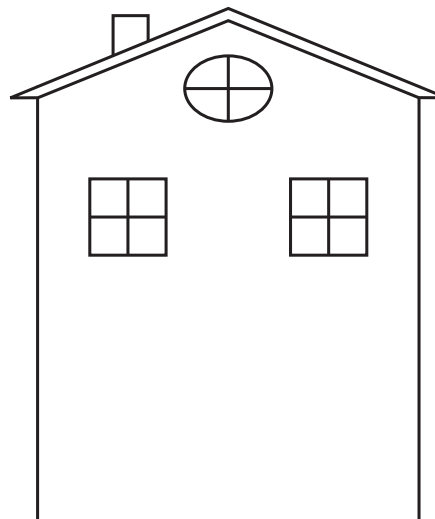
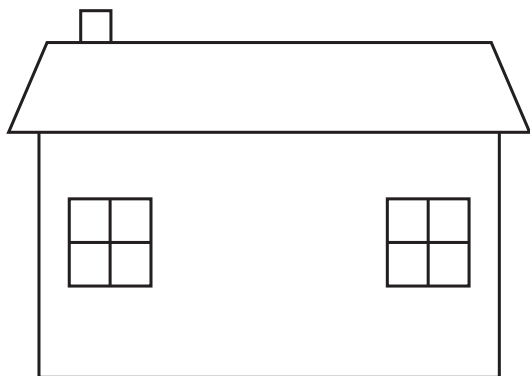
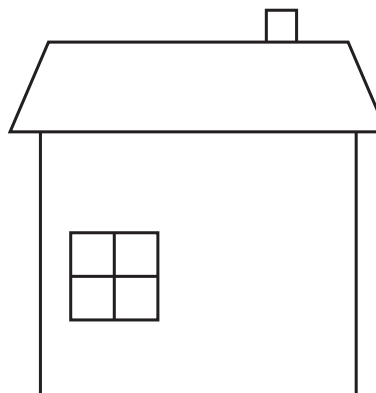
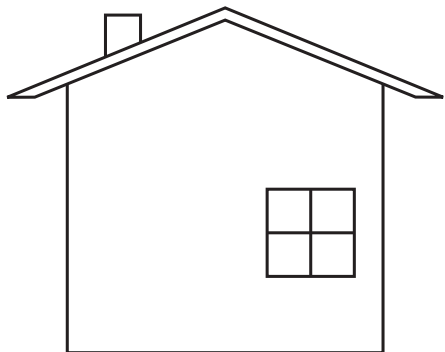
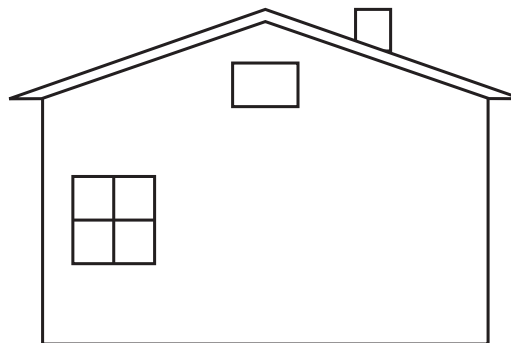
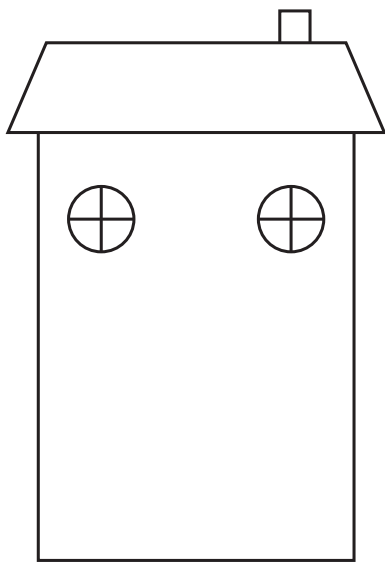

COPYRIGHT © 2017 JUMP MATH: PROHIBIDA LA REPRODUCCIÓN. EDICIÓN EN ESPAÑOL

Une con una línea cada  con una .

2.

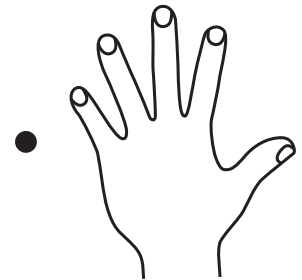
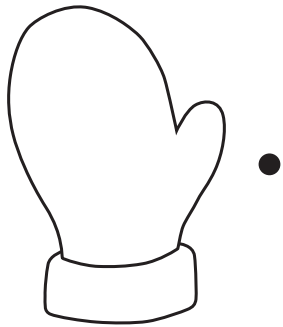
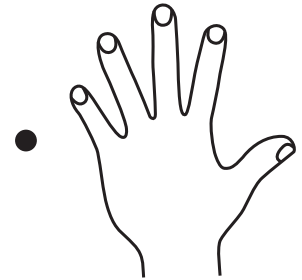
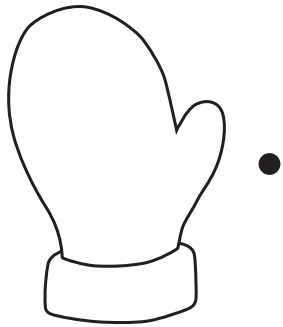
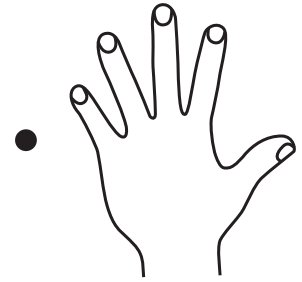
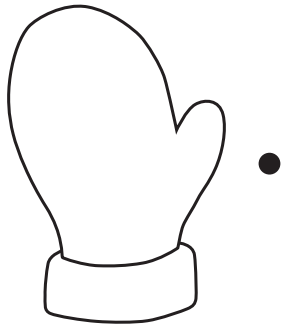

Une con una línea cada  con un .

3.



COPYRIGHT © 2017 JUMP MATH: PROHIBIDA LA REPRODUCCIÓN. EDICIÓN EN ESPAÑOL

CCInf-18 Igual a (contar)

¿Qué números son iguales?

Únelos con una línea.

1.

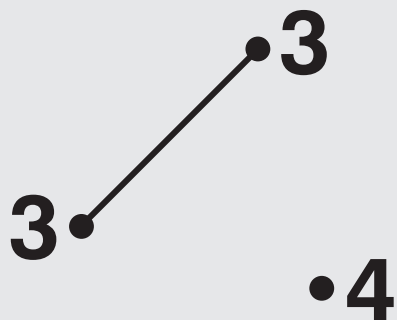

2.

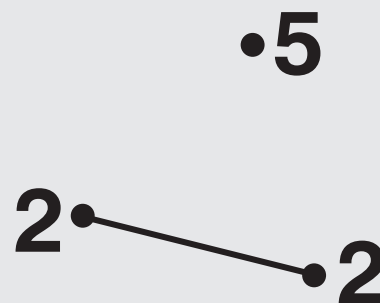

3.



4.

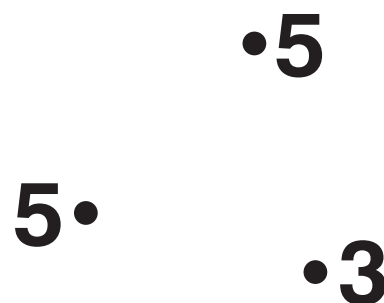

5.

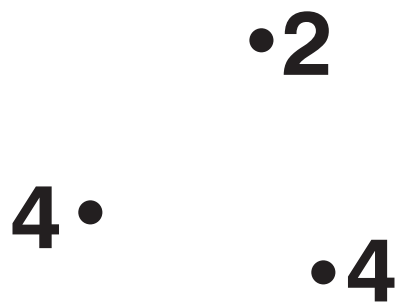

6.

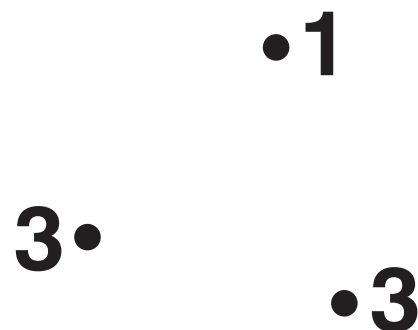

Cuenta. Rodea el número.

Colorea 😊 si son iguales. Colorea ☹️ si son diferentes.

7.



1 ② 3 4 5



① 2 3 4 5

8.



1 2 3 4 5



1 2 3 4 5

9.



1 2 3 4 5



1 2 3 4 5

Cuenta. Rodea el número.

Colorea 😊 si son iguales. Colorea ☹️ si son diferentes.

10.



1 2 3 4 5



1 2 3 4 5

11.



1 2 3 4 5



1 2 3 4 5

12.



1 2 3 4 5



1 2 3 4 5

CCInf-19 Mayor que (relacionar)

Une con una línea.

Colorea el ☀ del lado que tiene **más elementos**.

1.

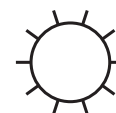
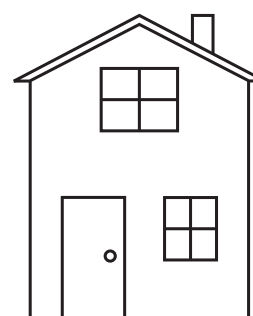
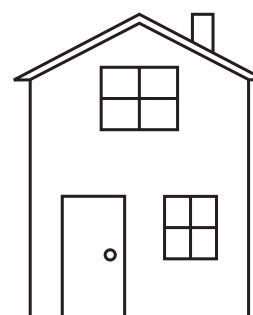
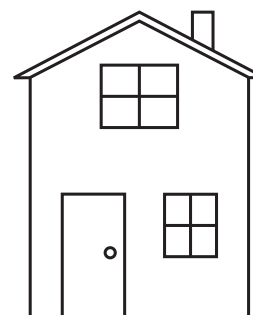
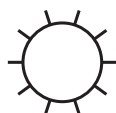
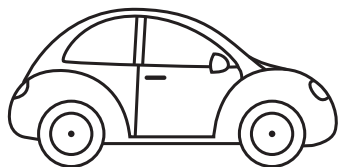
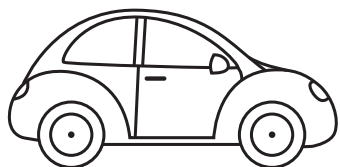
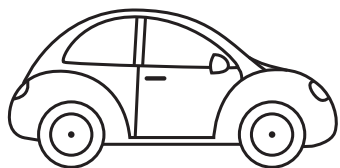

COPYRIGHT © 2017 JUMP MATH: PROHIBIDA LA REPRODUCCIÓN. EDICIÓN EN ESPAÑOL

Une con una línea.

Colorea el ☀ del lado que tiene **más elementos**.

2.

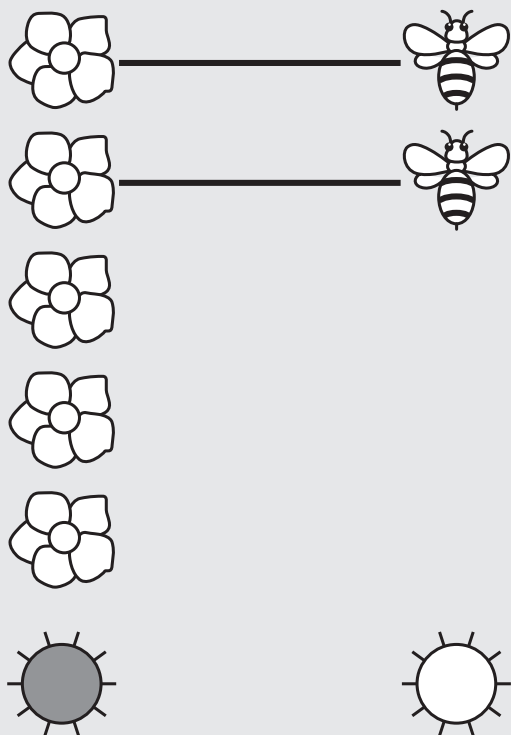

3.

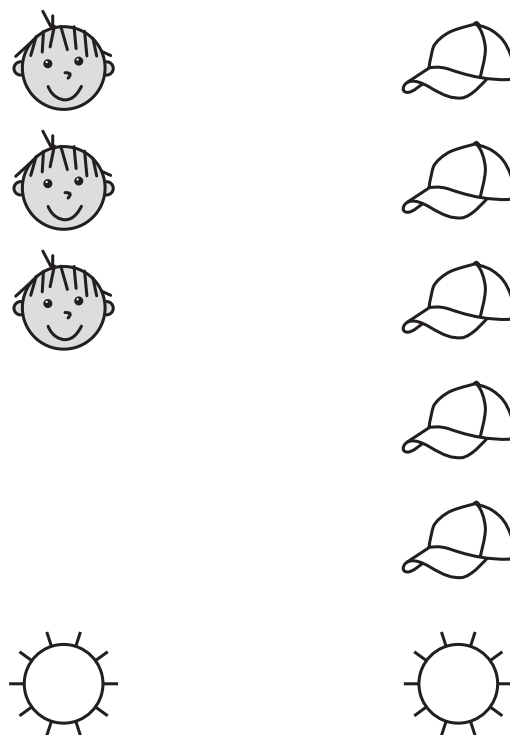

4.

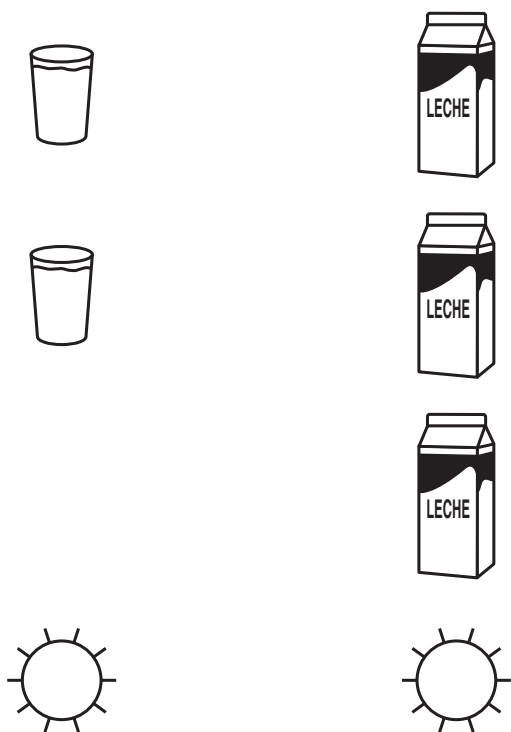

5.

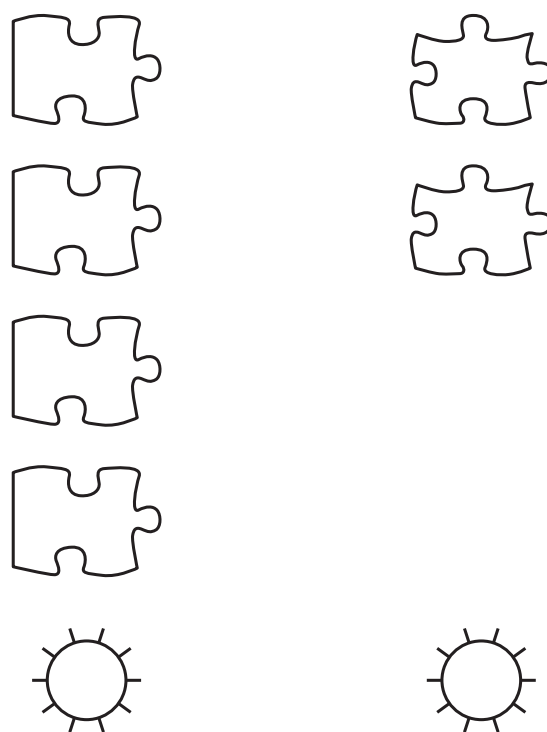

1 2 3 4 5

Rodea el número **mayor**.

1.

2

4

2.

3

1

3.

4

5

4.

2

5

5.

3

2

6.

4

3

7.

5

1

8.

1

4

Cuenta. Rodea el número.

Colorea el ☀ del número mayor.

9.

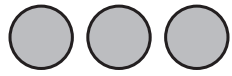

1

2

3

4

5

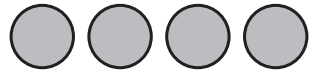
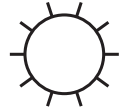

1

2

3

4

5

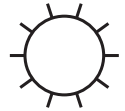

10.

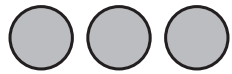

1

2

3

4

5

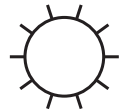

1

2

3

4

5

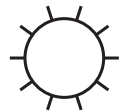

11.

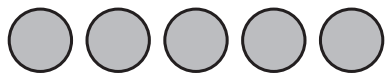

1

2

3

4

5

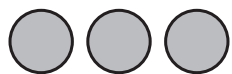
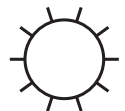

1

2

3

4

5

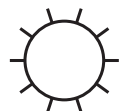

Cuenta. Rodea el número.

Colorea el ☀ del número mayor.

12.



1 2 3 4 5

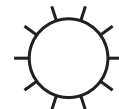

1 2 3 4 5

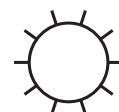

13.



1 2 3 4 5

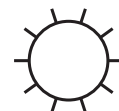

1 2 3 4 5

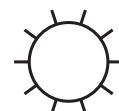

14.



1 2 3 4 5

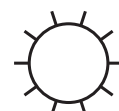

1 2 3 4 5

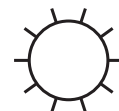

COPYRIGHT © 2017 JUMP MATH: PROHIBIDA LA REPRODUCCIÓN. EDICIÓN EN ESPAÑOL

CCInf-21 *Menor que (relacionar)*

Colorea el ☀ del grupo que tiene **menos elementos**.

1.

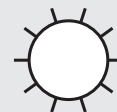
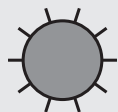
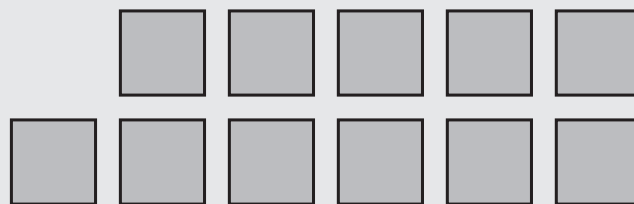

2.

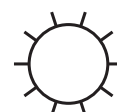
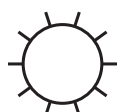
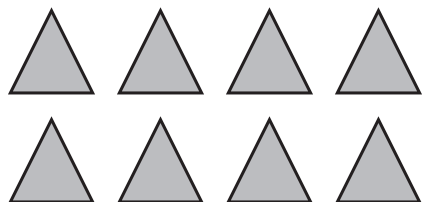

3.

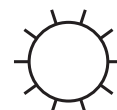
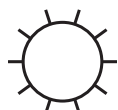
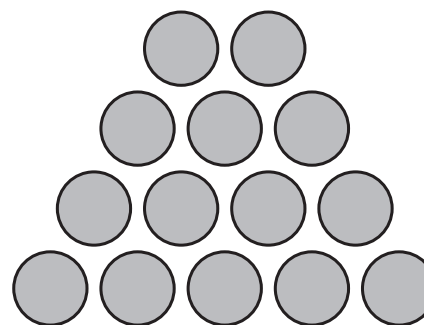
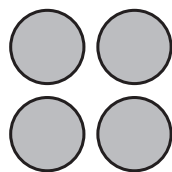

COPYRIGHT © 2017 JUMP MATH: PROHIBIDA LA REPRODUCCIÓN. EDICIÓN EN ESPAÑOL

Une con una línea.

Colorea el ☀ del lado que tiene menos elementos.

4.

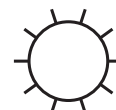
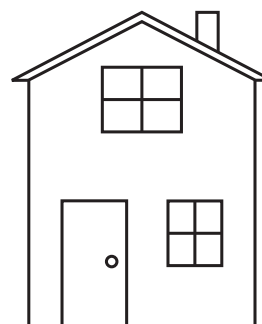
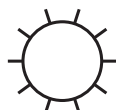
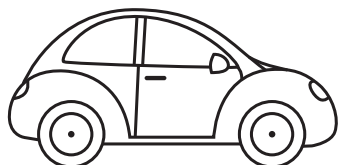
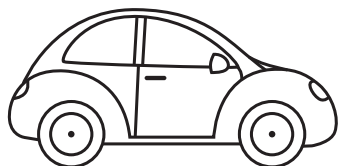
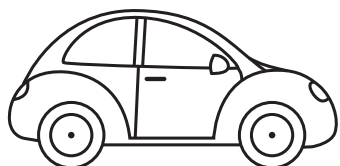

COPYRIGHT © 2017 JUMP MATH: PROHIBIDA LA REPRODUCCIÓN. EDICIÓN EN ESPAÑOL

Únelos con una línea.

Colorea el ☀ del lado que tiene menos elementos.

5.

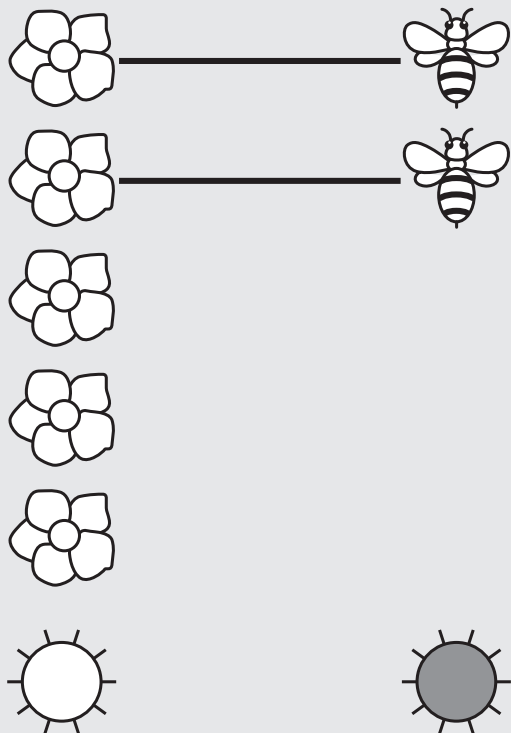

6.

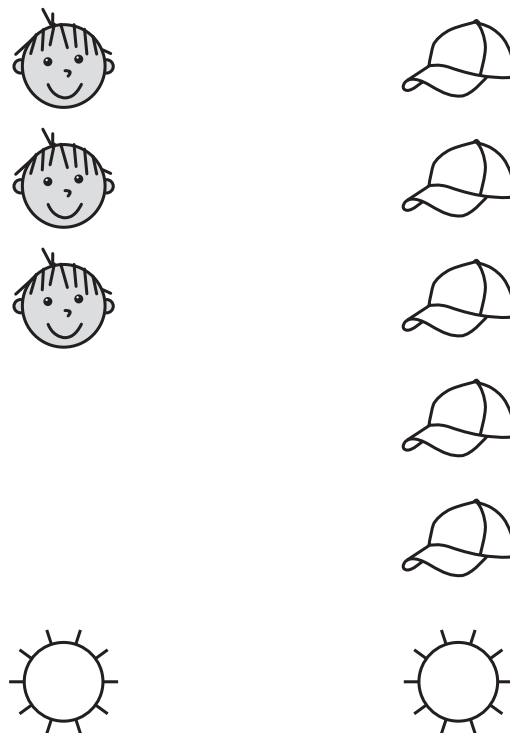

7.

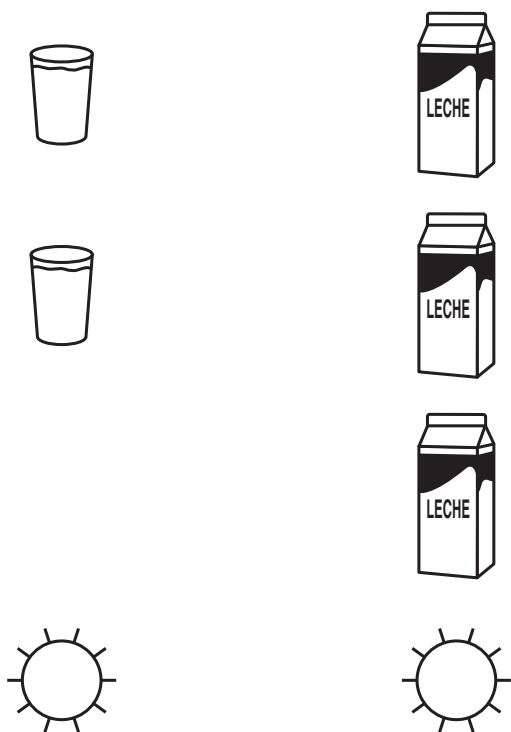

8.

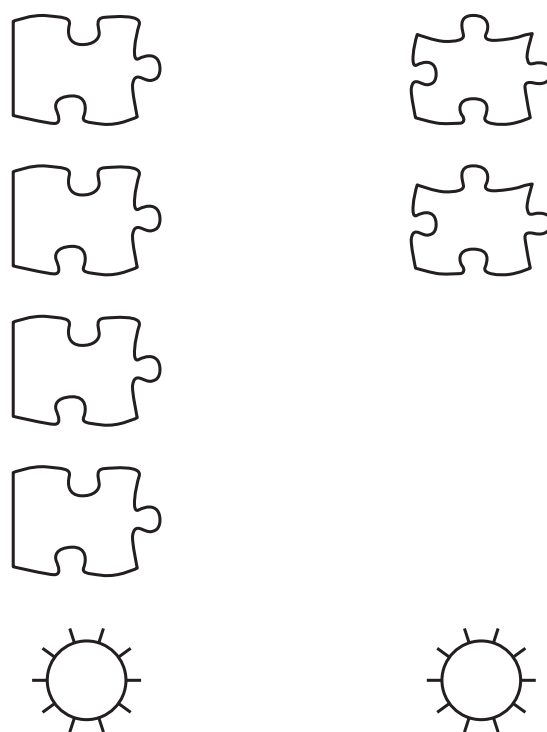

CCInf-22 Menor que (contar)

1 2 3 4 5

Rodea el número **menor**.

1.

②

4

2.

3

①

3.

4

5

4.

2

5

5.

3

2

6.

4

3

7.

5

1

8.

1

4

Cuenta. Rodea el número.

Colorea el ☀ del número menor.

9.

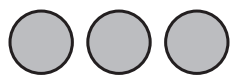

1 2 3 4 5

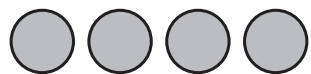
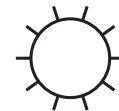

1 2 3 4 5

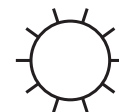

10.



1 2 3 4 5

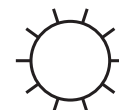

1 2 3 4 5

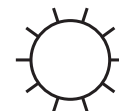

11.

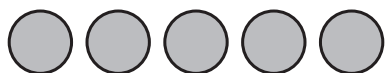

1 2 3 4 5

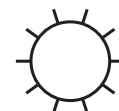

1 2 3 4 5

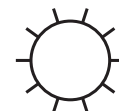

Cuenta. Rodea el número.

Colorea el ☀ del número menor.

12.

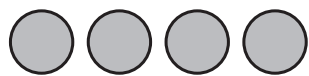

1 2 3 4 5

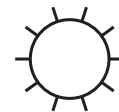

1 2 3 4 5

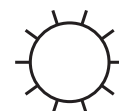

13.

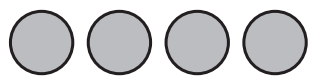

1 2 3 4 5

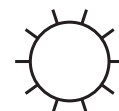

1 2 3 4 5

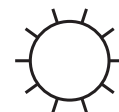

14.



1 2 3 4 5

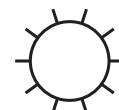

1 2 3 4 5

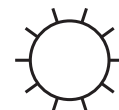

COPYRIGHT © 2017 JUMP MATH: PROHIBIDA LA REPRODUCCIÓN. EDICIÓN EN ESPAÑOL

CCInf-23 Cero

Colorea el ☀ para indicar cuál es 0.

1.



2.

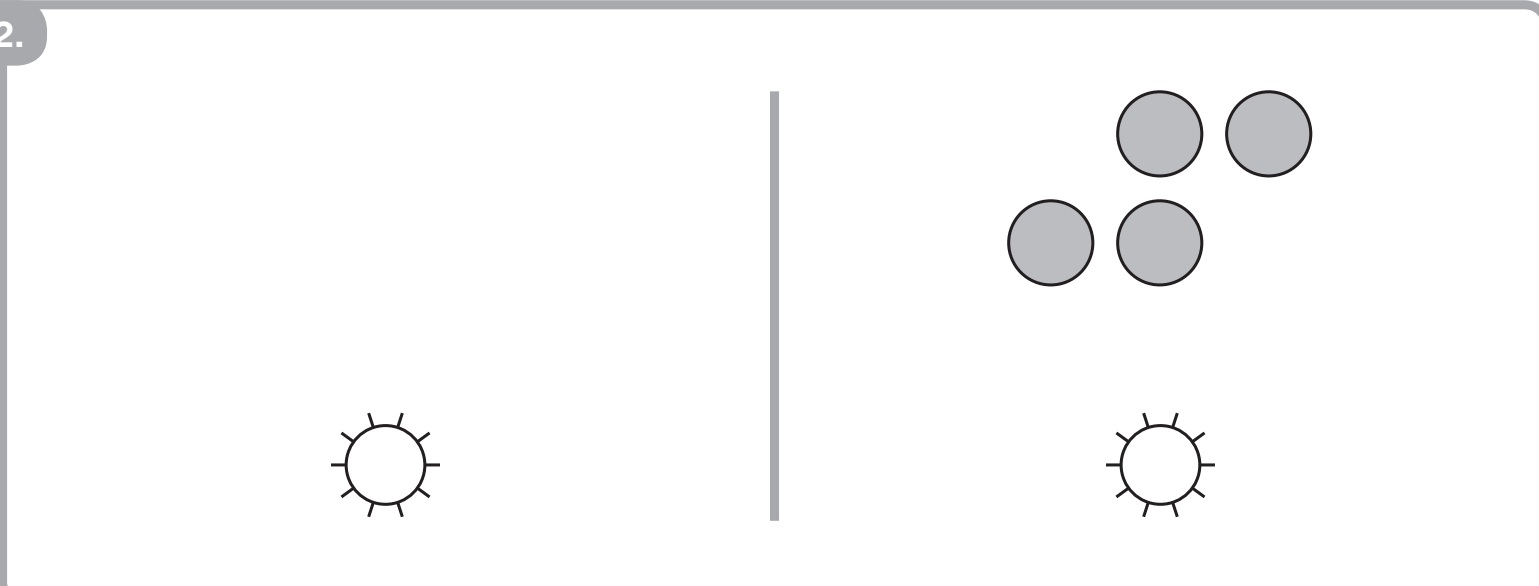

3.



COPYRIGHT © 2017 JUMP MATH: PROHIBIDA LA REPRODUCCIÓN. EDICIÓN EN ESPAÑOL

Colorea los puntos que indican los números.

4.

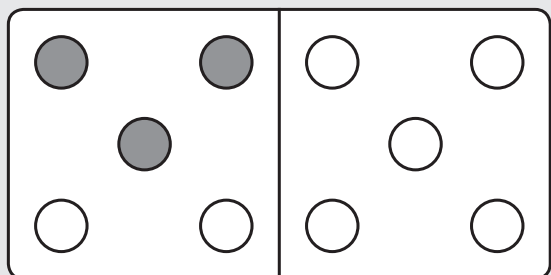

3

0

5.

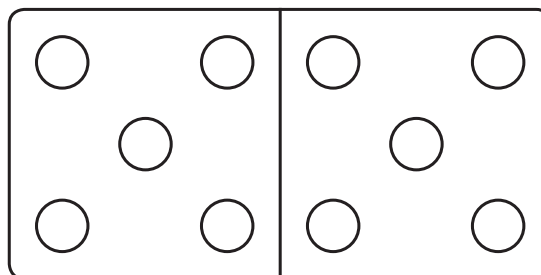

1

4

6.

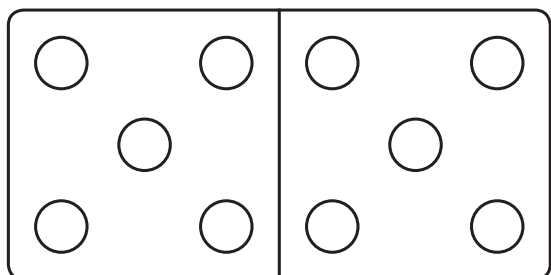

5

1

7.

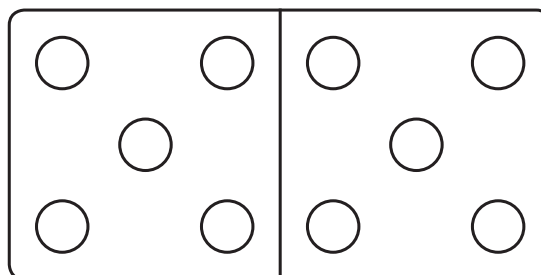

0

2

8.

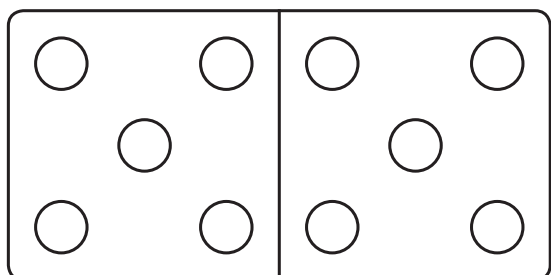

0

4

9.

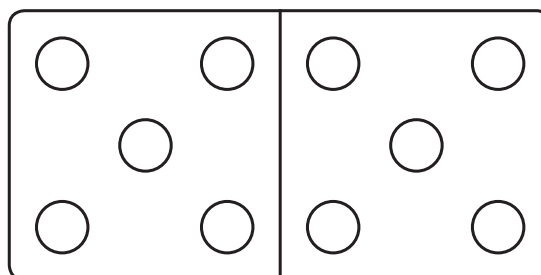

3

5

0 1 2 3 4 5

Rodea el número **menor**.

10.

2

0

11.

0

4

12.

0

1

13.

3

1

14.

4

0

15.

2

5

16.

4

5

17.

3

0

Repasa.

18.

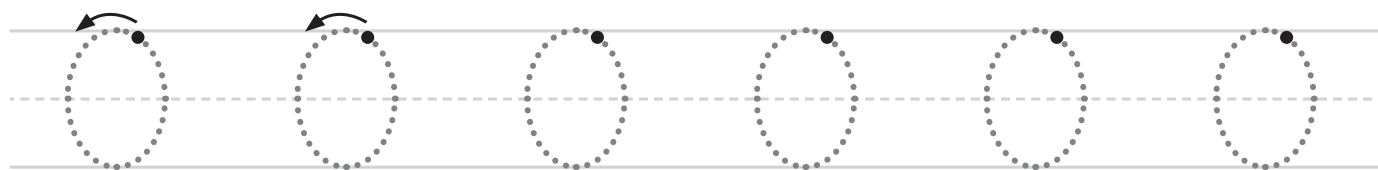
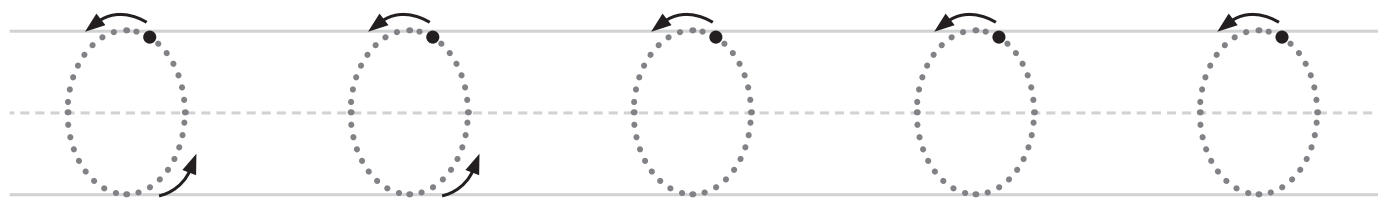
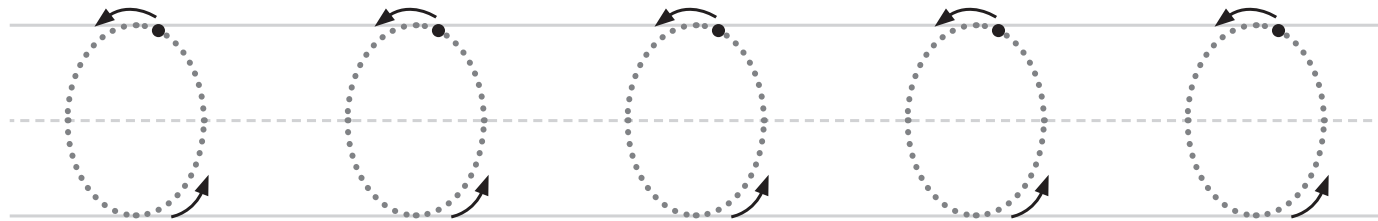
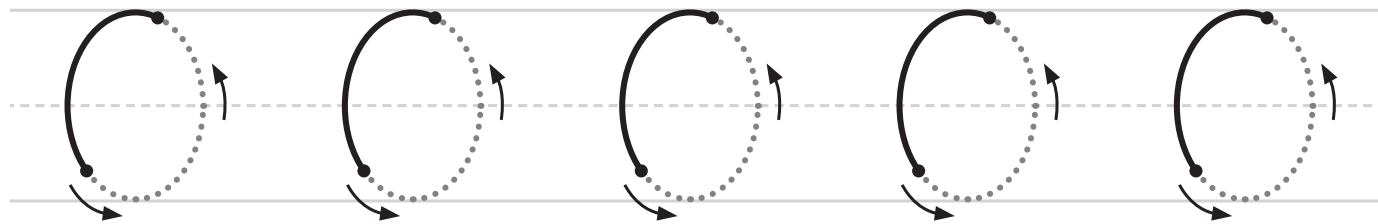
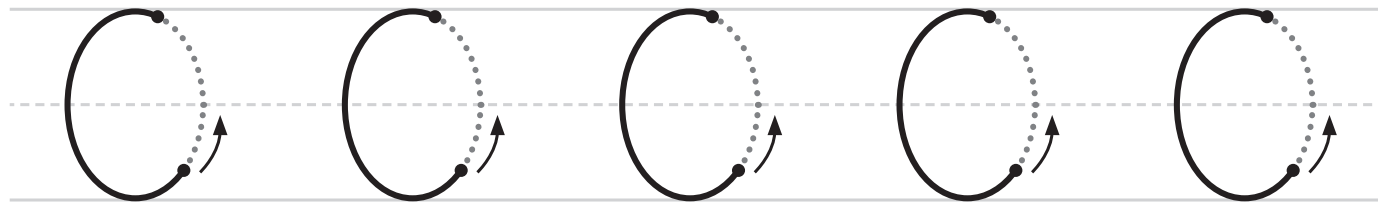
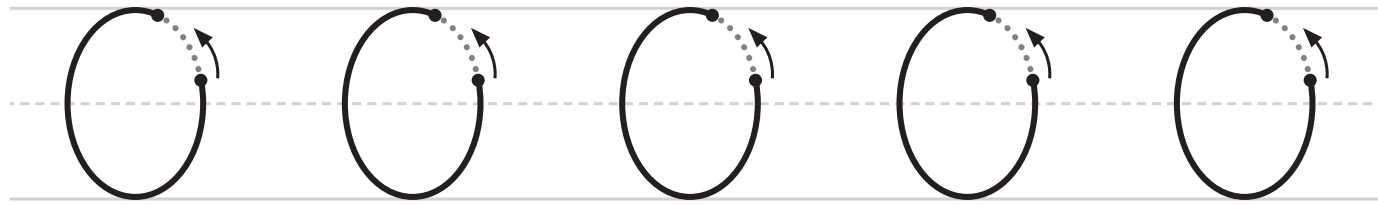

COPYRIGHT © 2017 JUMP MATH: PROHIBIDA LA REPRODUCCIÓN. EDICIÓN EN ESPAÑOL

CCInf-24 Comparar números del 1 al 5

- Colorea los círculos que indican los números.
- Únelos con una línea.

1.

1 **2**

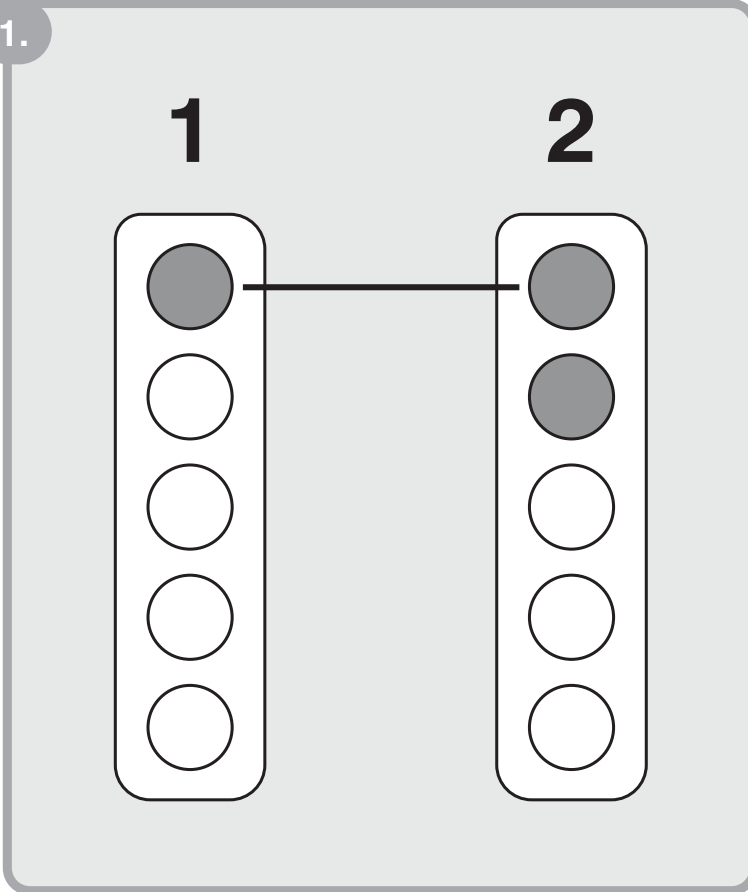

2.

3 **1**

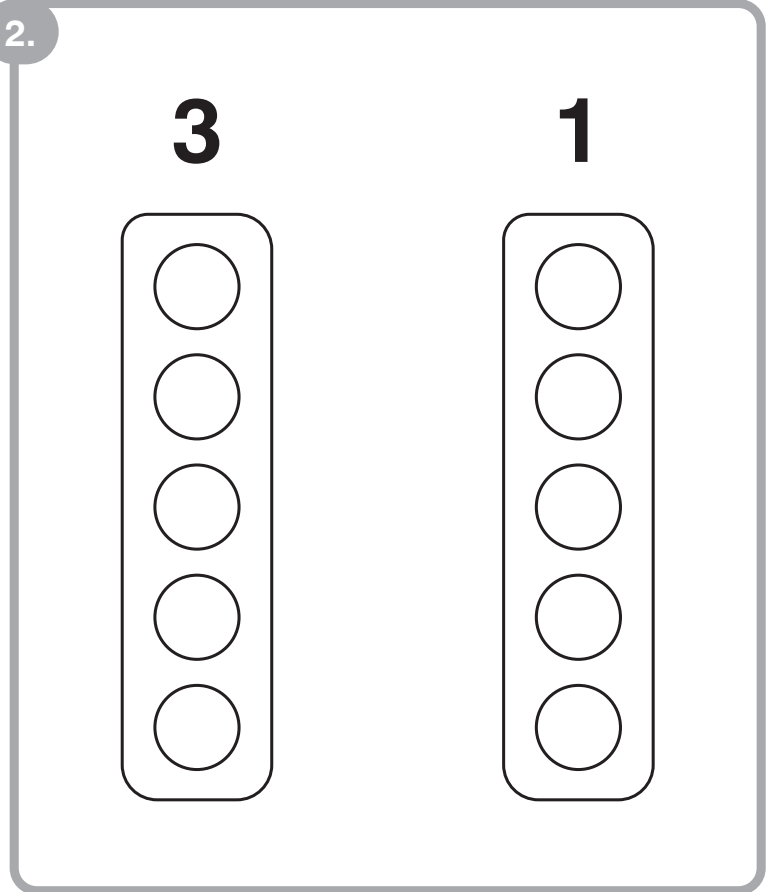

3.

2 **5**

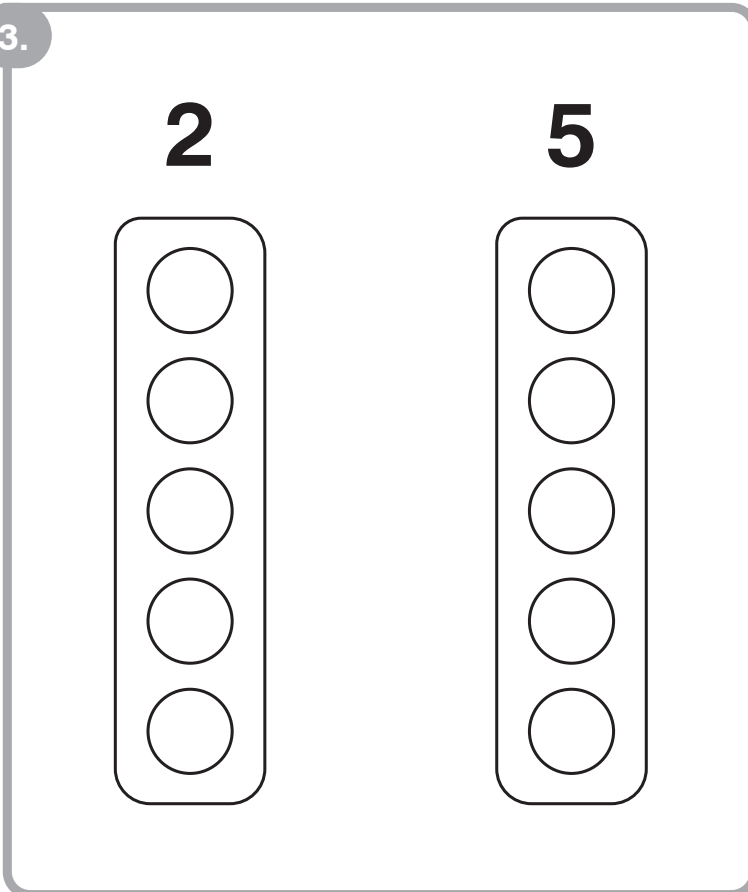

4.

4 **3**

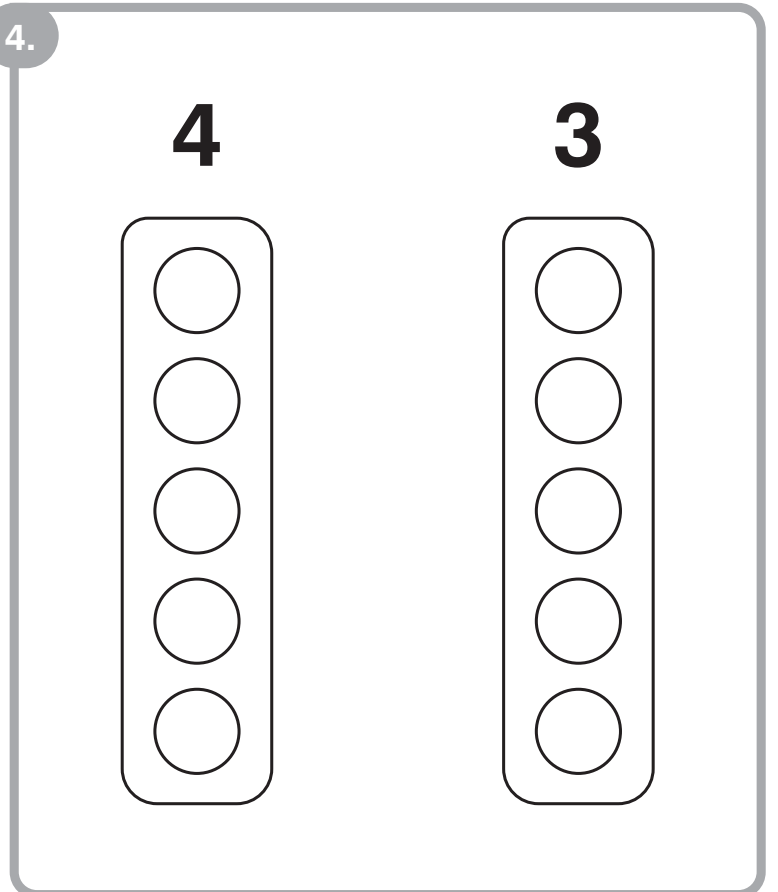

Colorea los círculos que indican los números y únelos.

Colorea el ☀ del número mayor.

5.

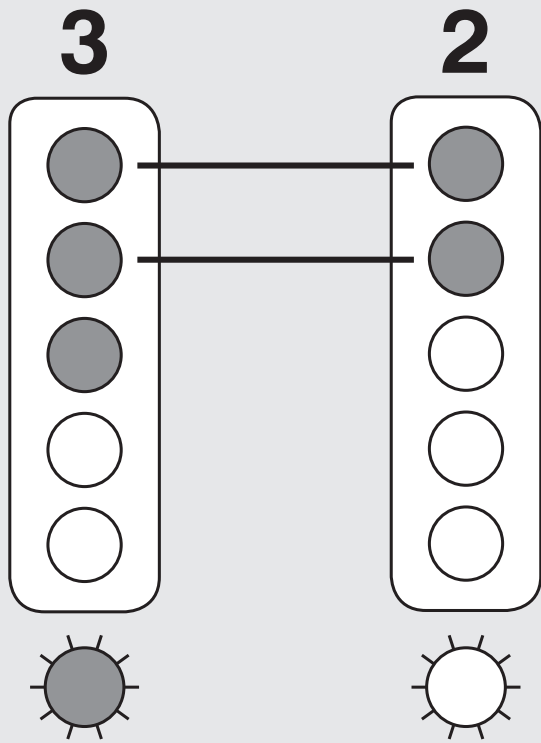

6.

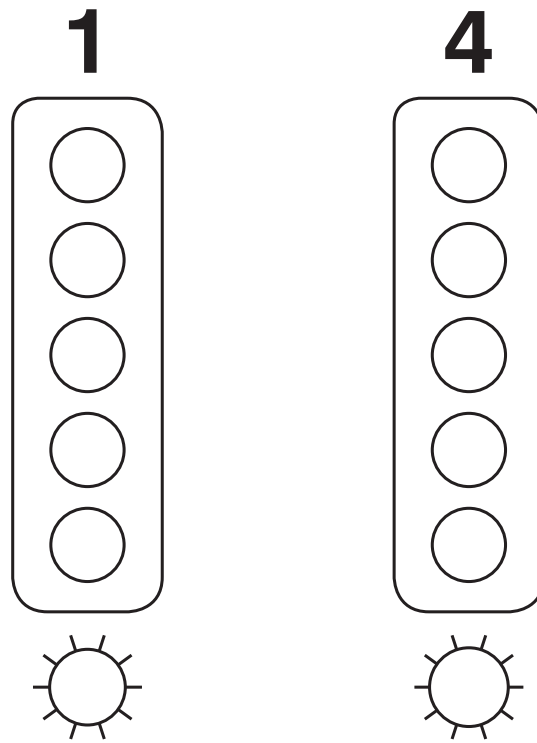

7.

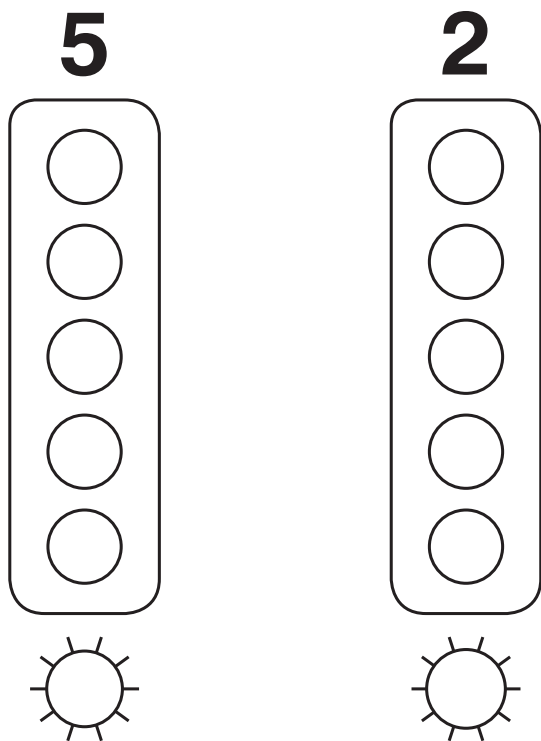

8.

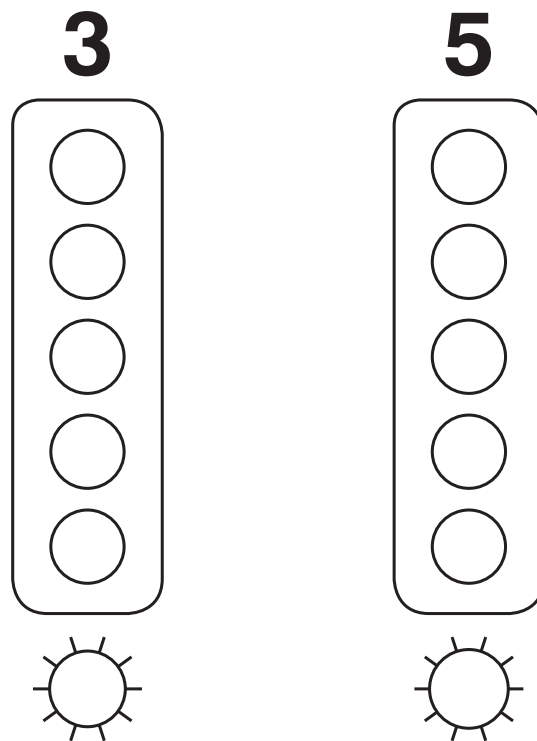

Colorea los círculos que indican los números y únelos.

Colorea el ☀ del número menor.

9.

3 **1**

☀ ☀

10.

2 **4**

☀ ☀

11.

5 **4**

☀ ☀

12.

2 **3**

☀ ☀

GIInf-1 Contar hasta el 30

Repasa.

1.

20

21

22

23

24

25

26

27

28

29

30

2.

2 2 2 2 2 2 2

Escribe el 2.

3.

GInf-2 Círculos

Cuenta los ○.

1.

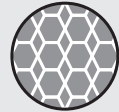
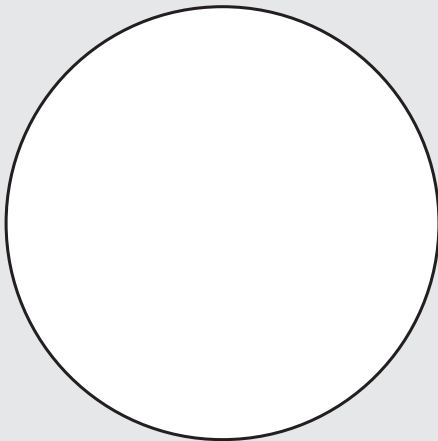
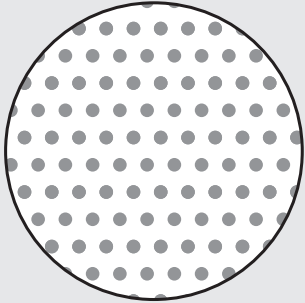

1

2

3

4

5

2.

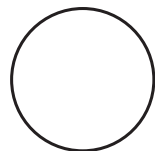
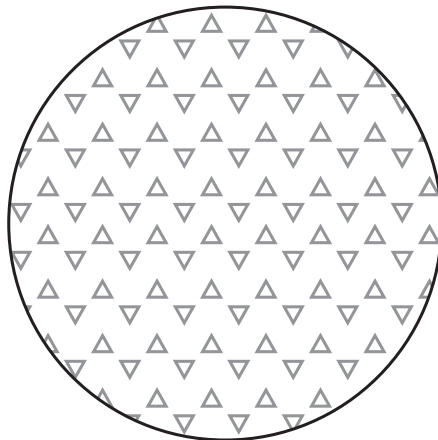
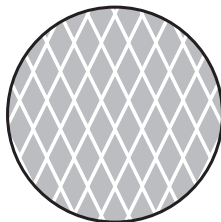
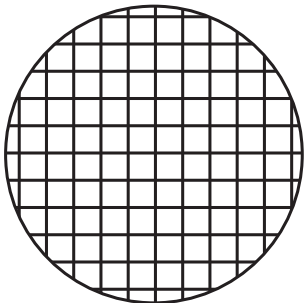

1

2

3

4

5

COPYRIGHT © 2017 JUMP MATH: PROHIBIDA LA REPRODUCCIÓN. EDICIÓN EN ESPAÑOL

- Colorea los ○.
- Dibuja una ✕ en las otras figuras.

3.

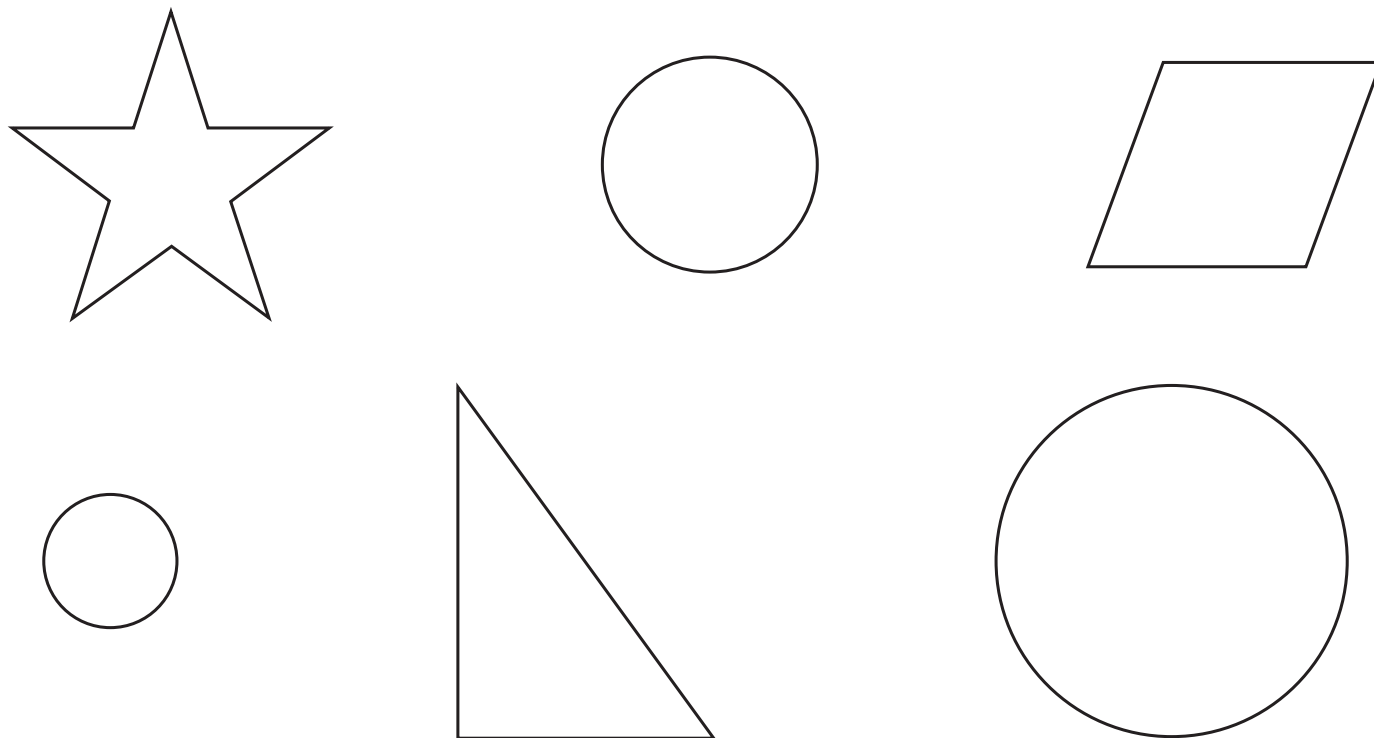

4.

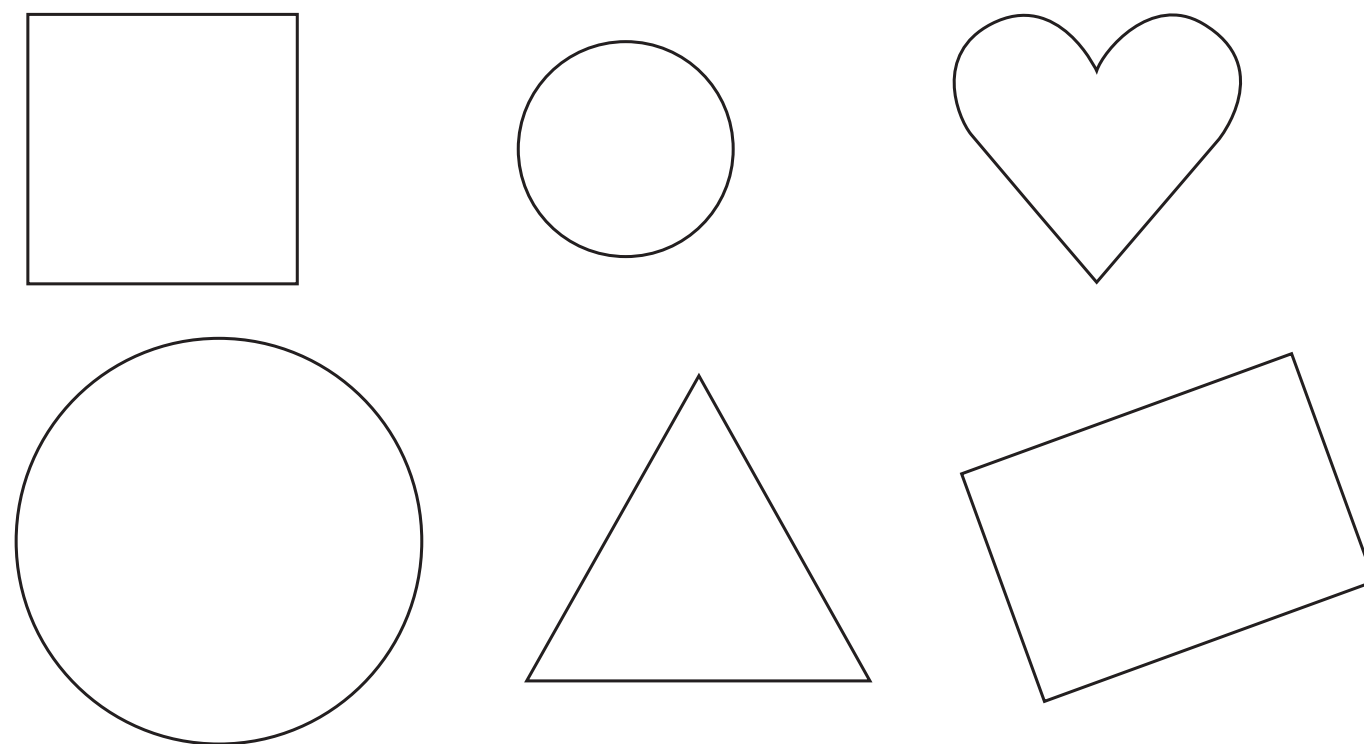

Colorea los ○.

Dibuja una ✕ en las otras figuras.

5.

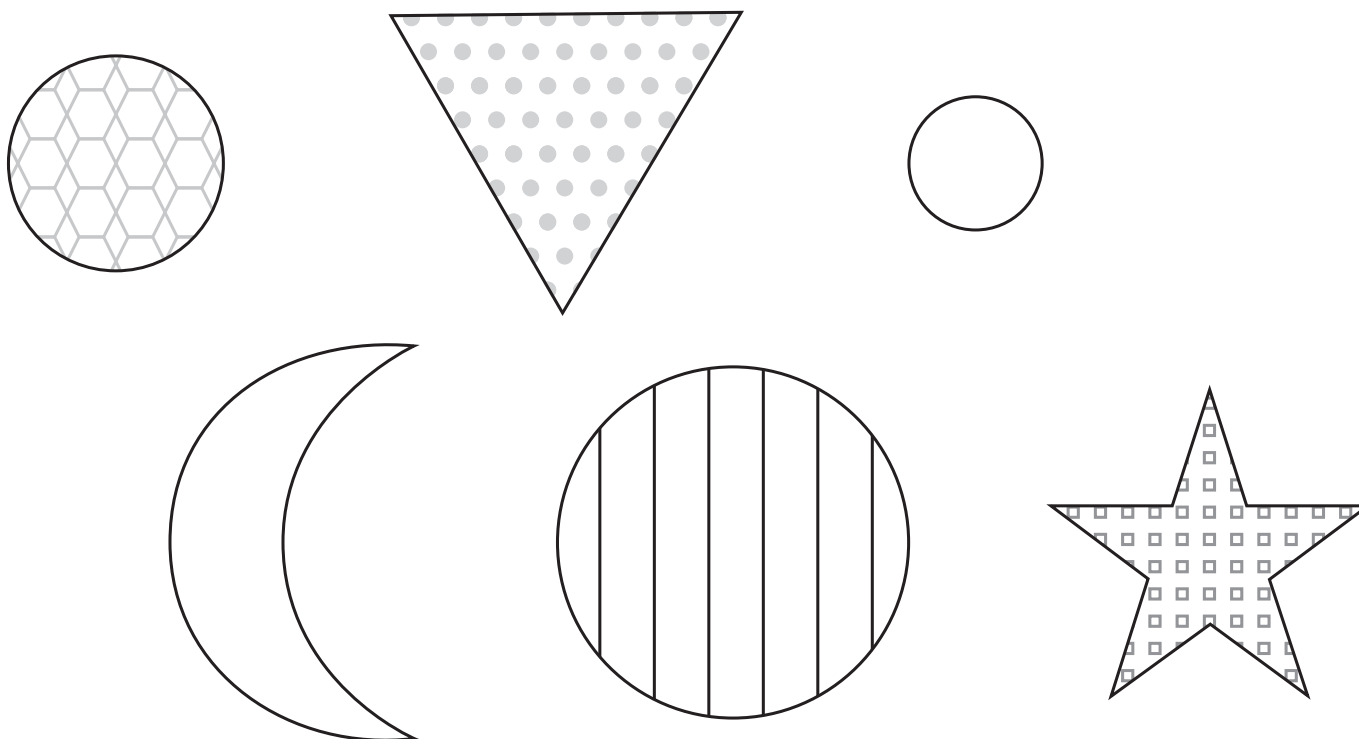

6.

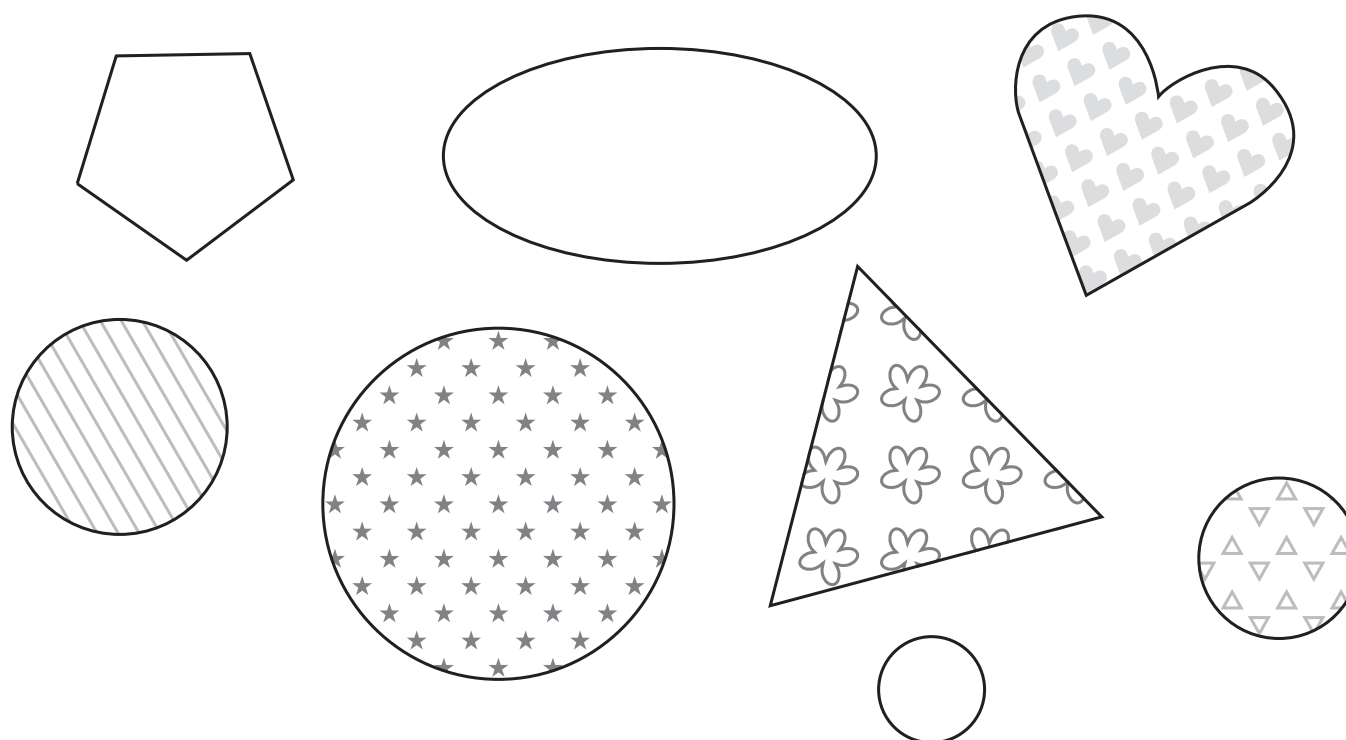

GInf-3 Cuadrados

Cuenta los .

1.

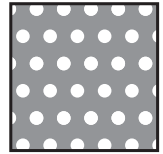
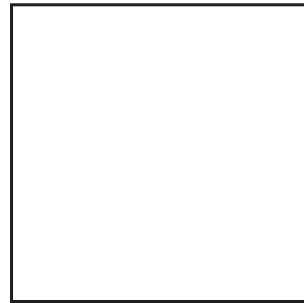
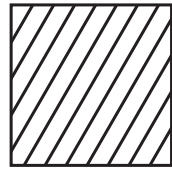
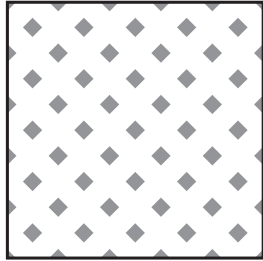

1

2

3

4

5

2.

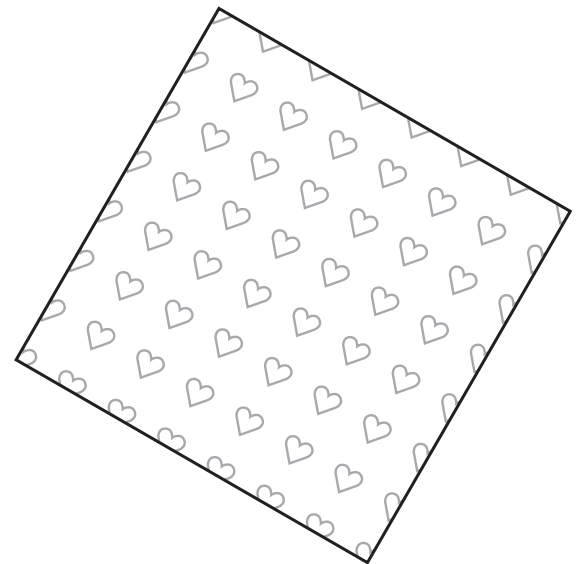
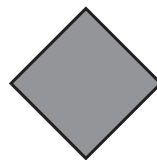
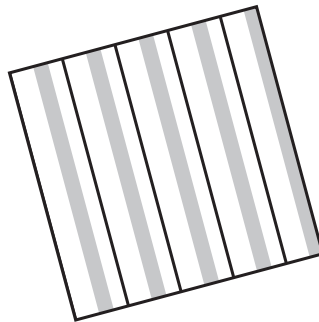
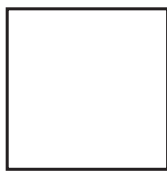

1

2

3

4

5

Colorea los .

Dibuja una  en las otras figuras.

3.

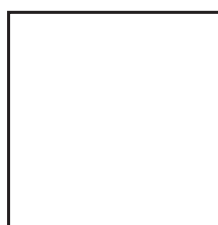
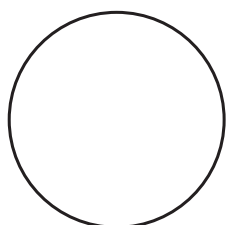
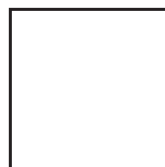
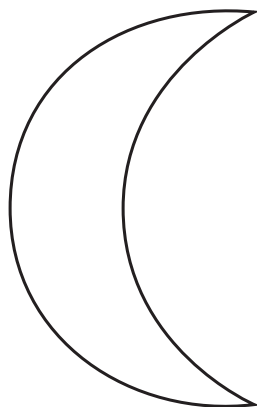
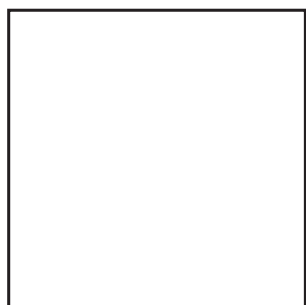

4.

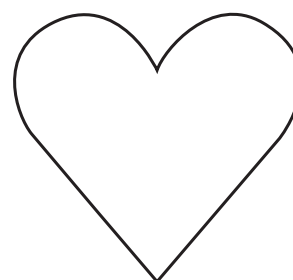
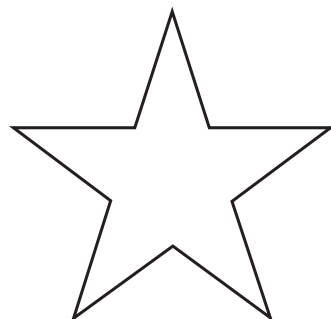
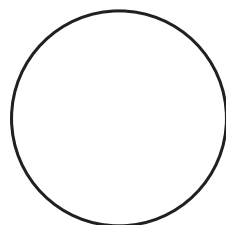
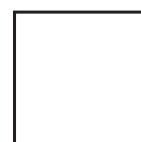
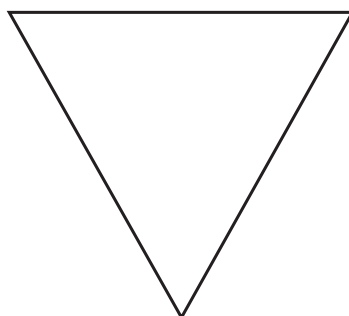
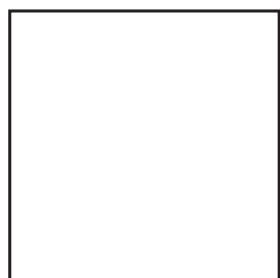

- Colorea los .
- Dibuja una  en las otras figuras.

5.

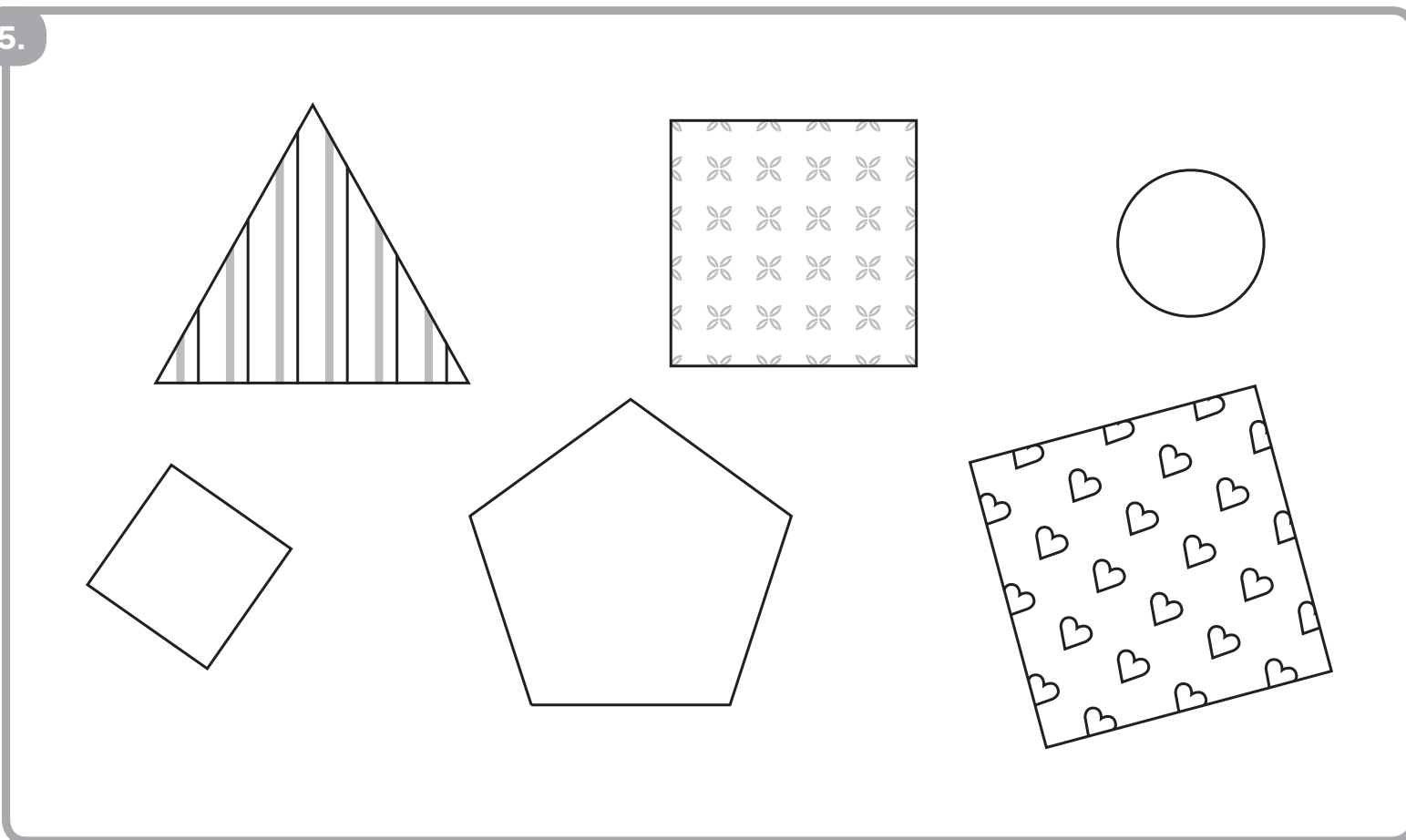

6.

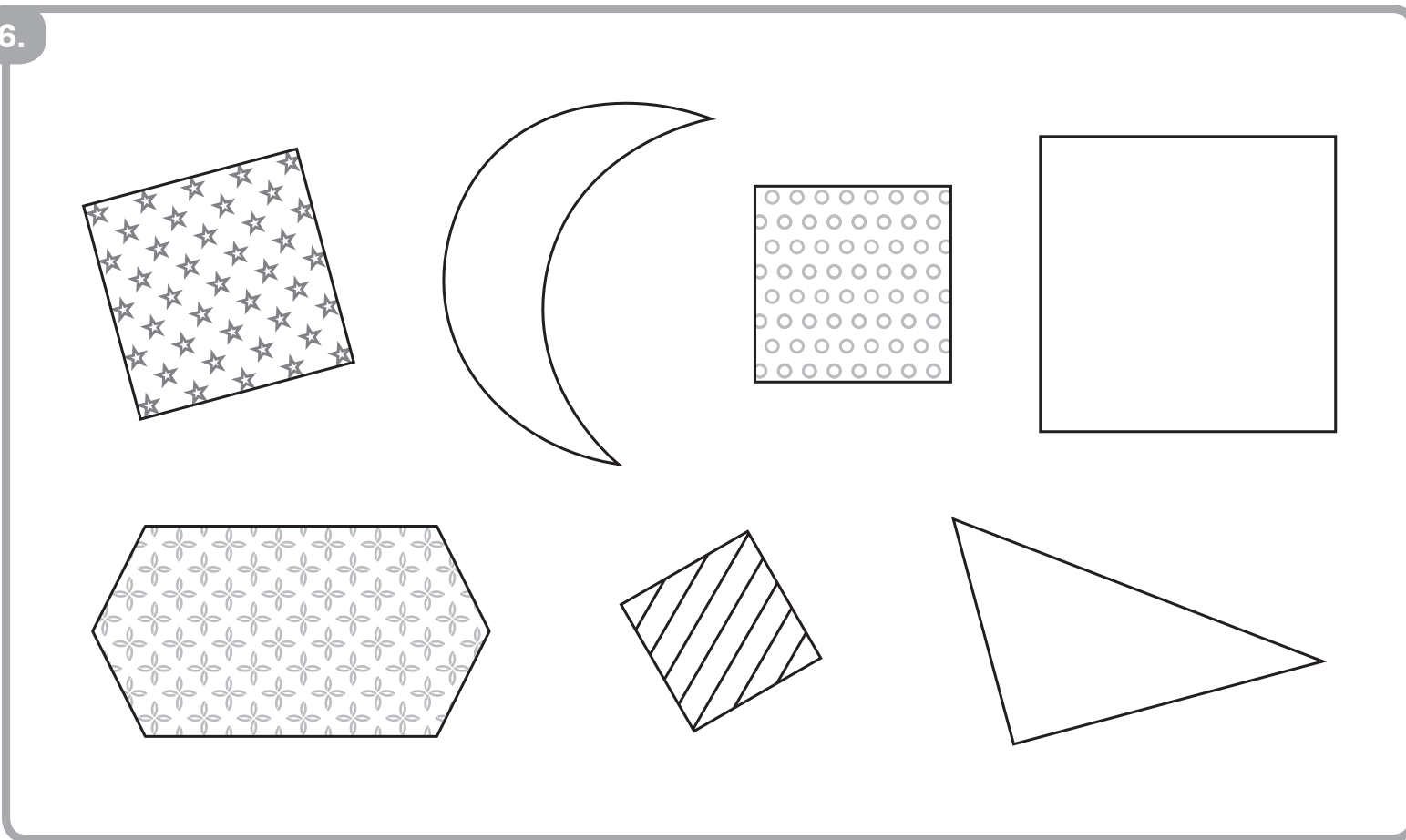

Inf-4 Rectángulos

Cuenta los .

1.

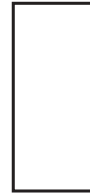
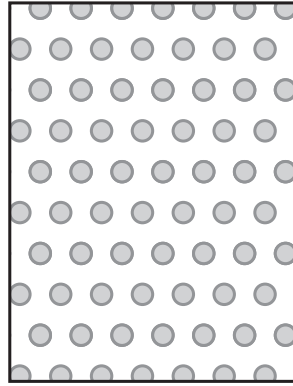
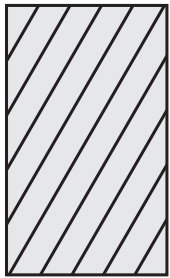

1

2

3

4

5

2.

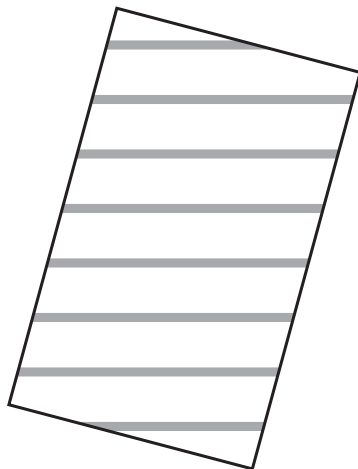
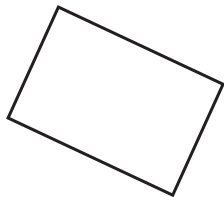
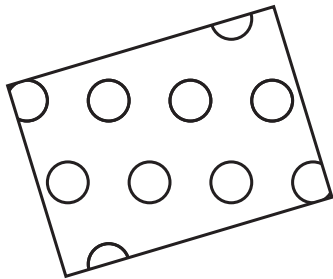
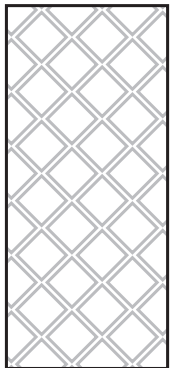

1



2

3

4

5

COPYRIGHT © 2017 JUMP MATH: PROHIBIDA LA REPRODUCCIÓN. EDICIÓN EN ESPAÑOL

- Colorea los .
- Dibuja una  en las otras figuras.

3.

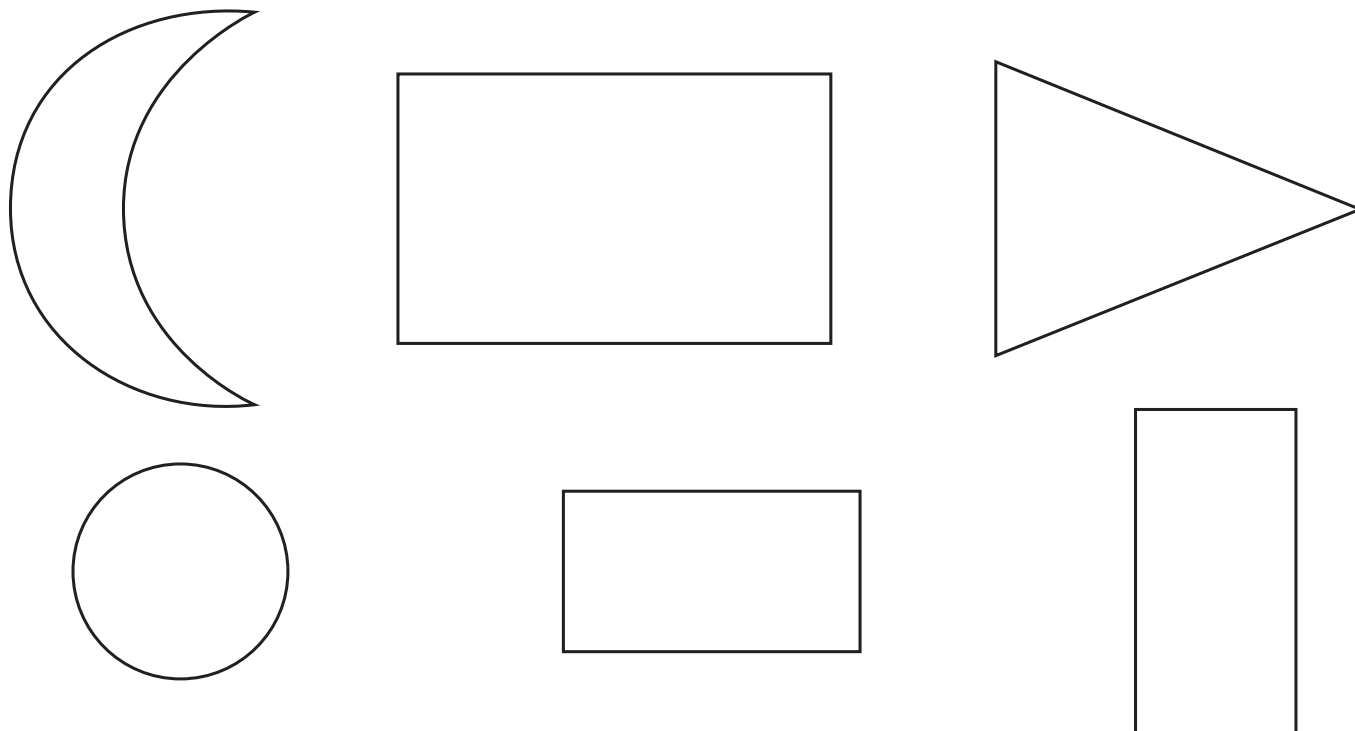

4.

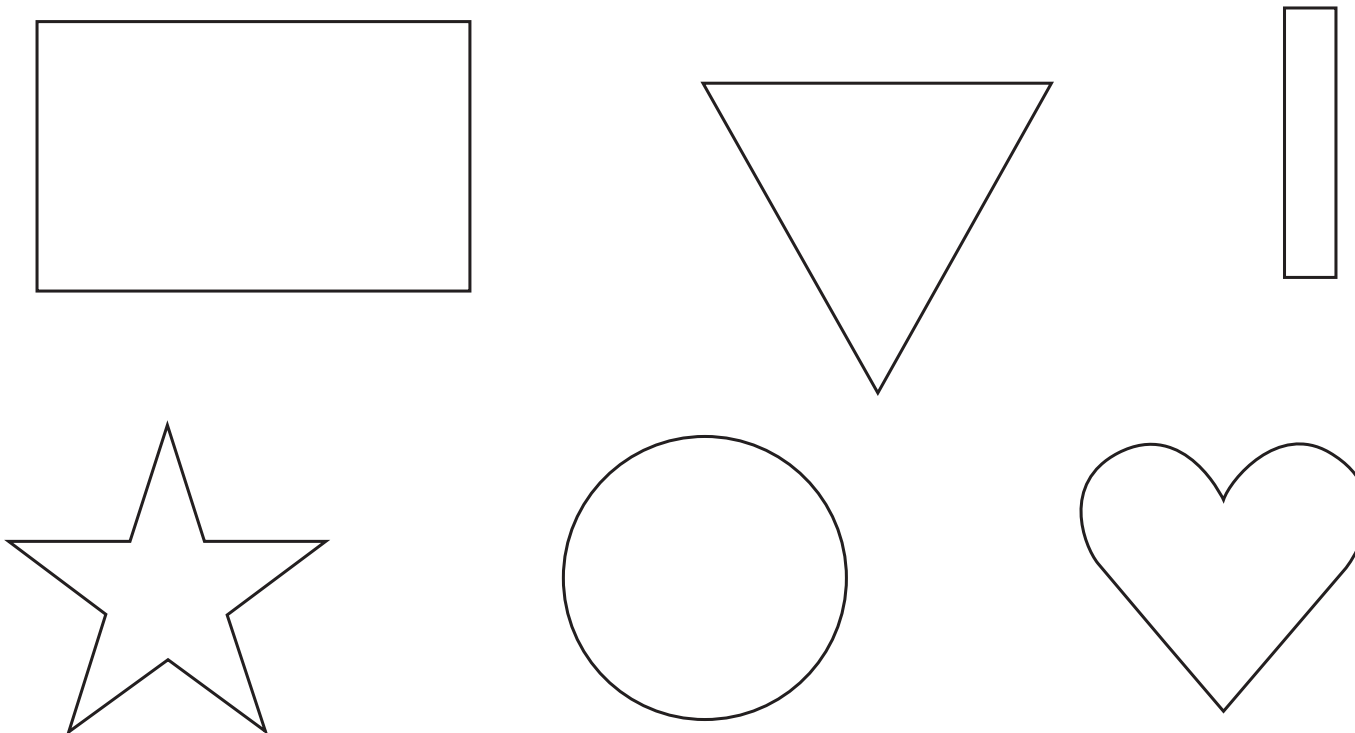

Colorea los .

Dibuja una  en las otras figuras.

5.

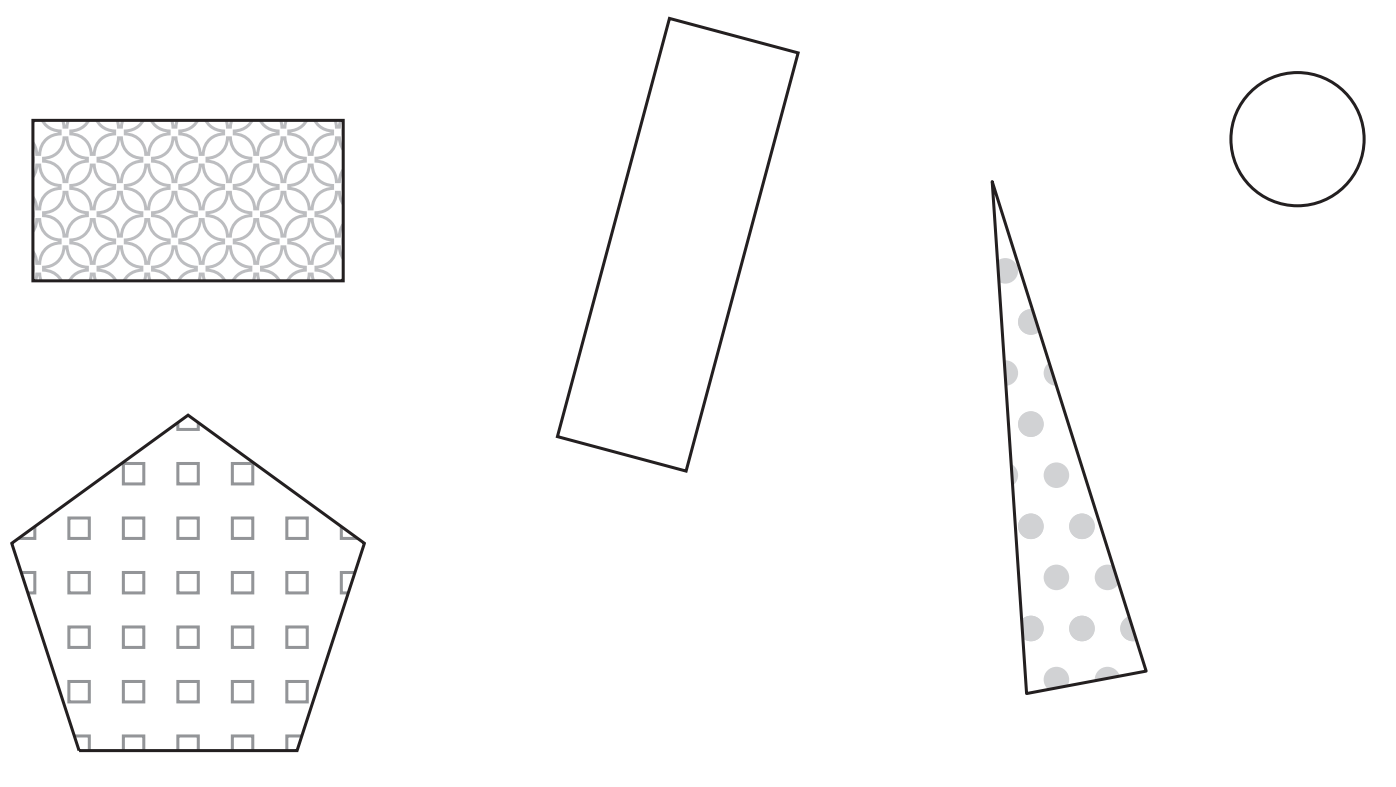

6.

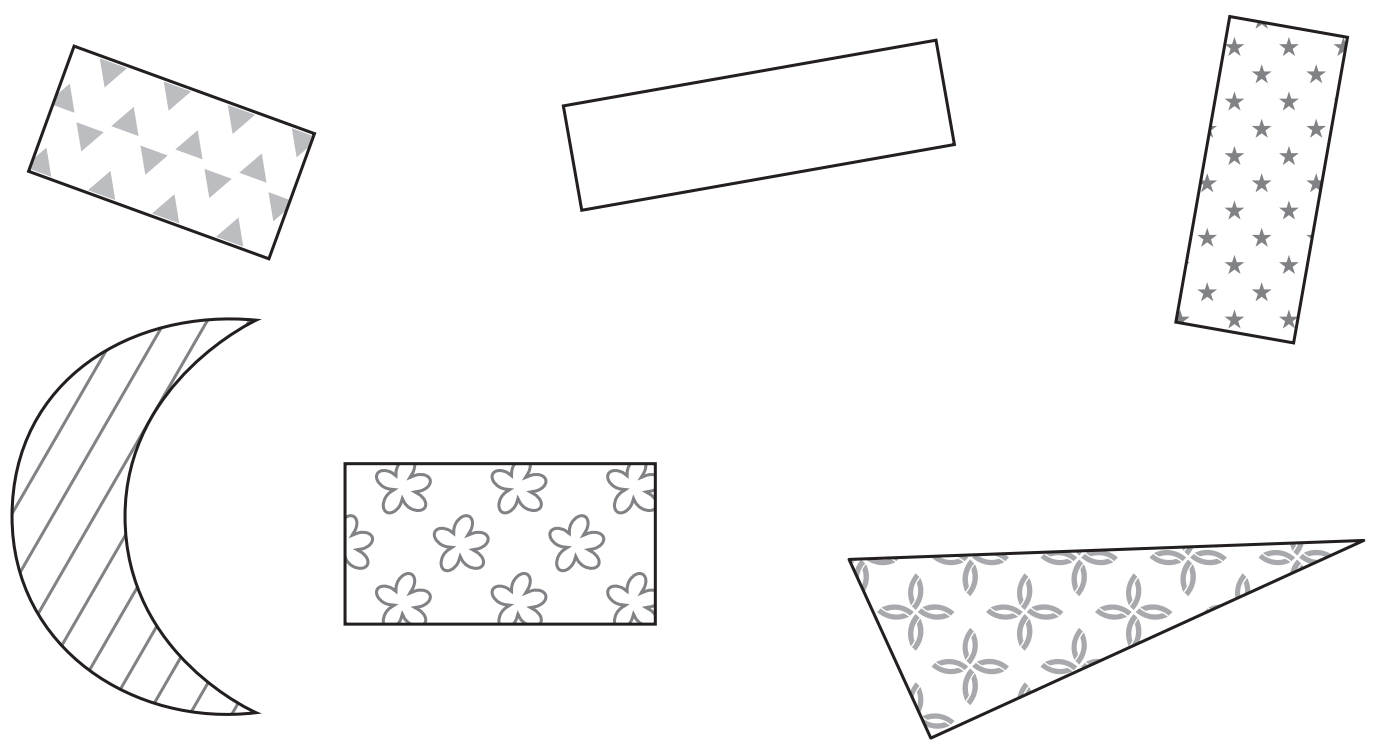

COPYRIGHT © 2017 JUMP MATH: PROHIBIDA LA REPRODUCCIÓN. EDICIÓN EN ESPAÑOL

GIInf-5 Esquinas y lados

Dibuja ● en cada esquina.

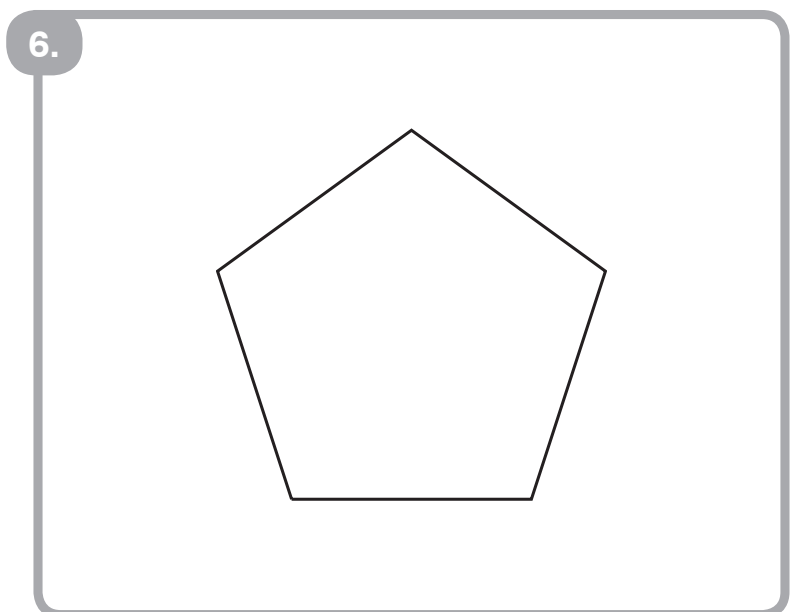
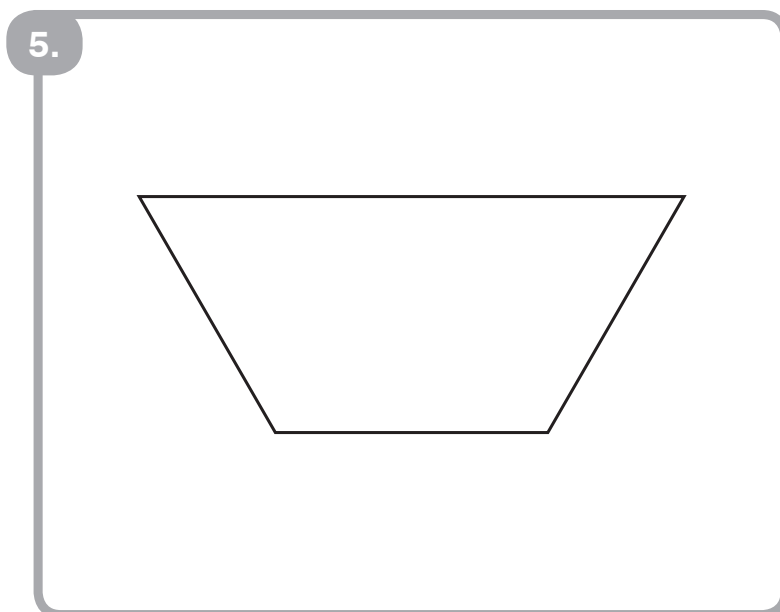
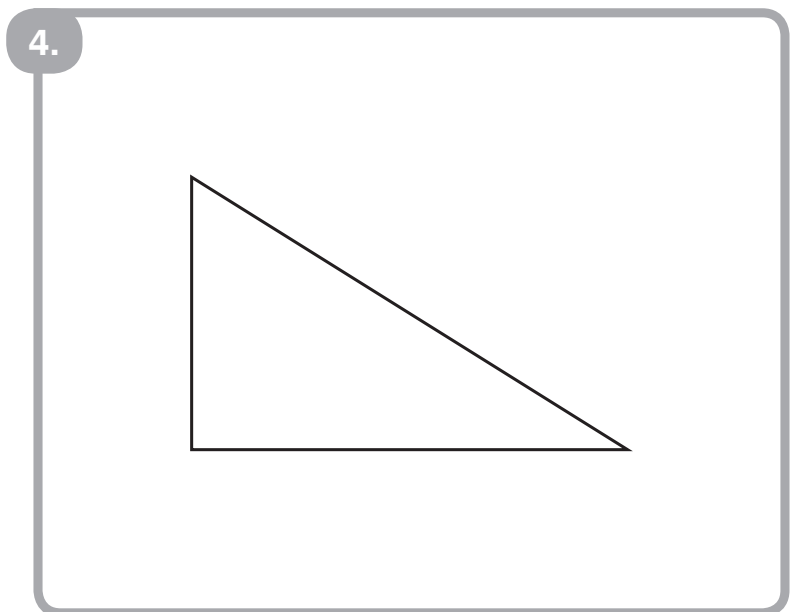
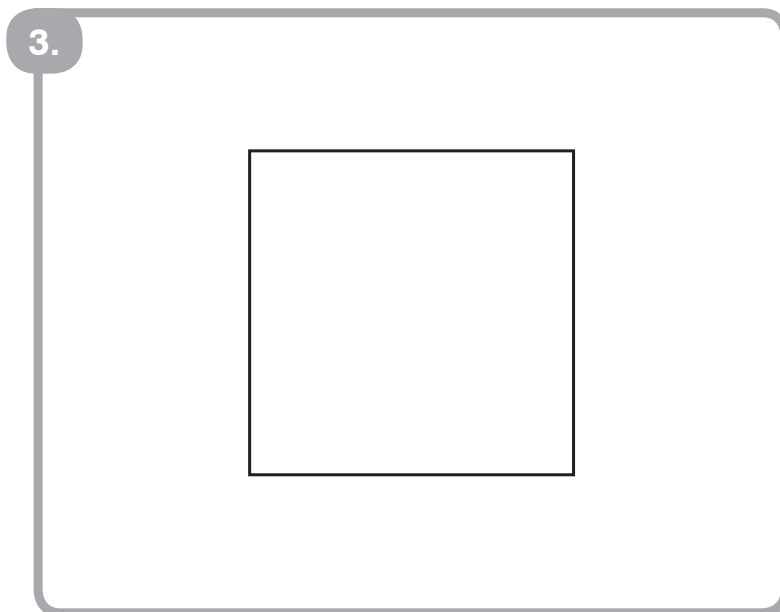
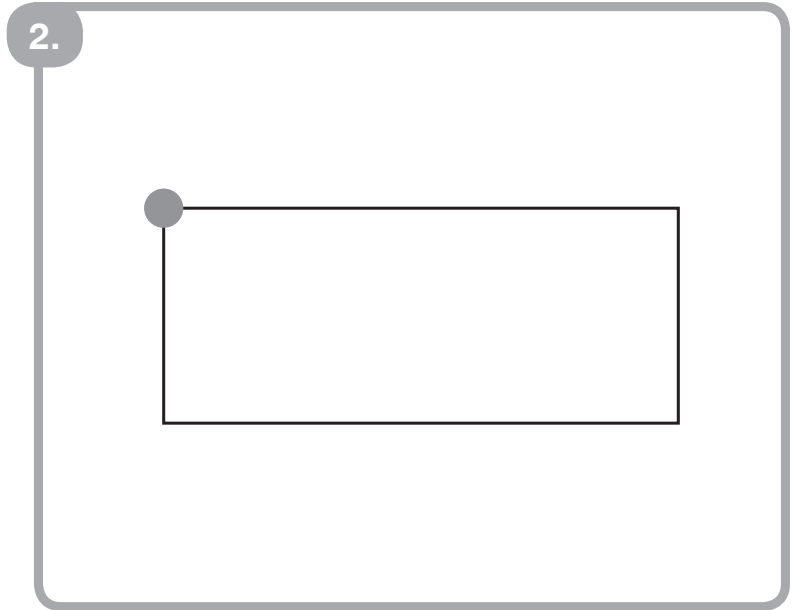
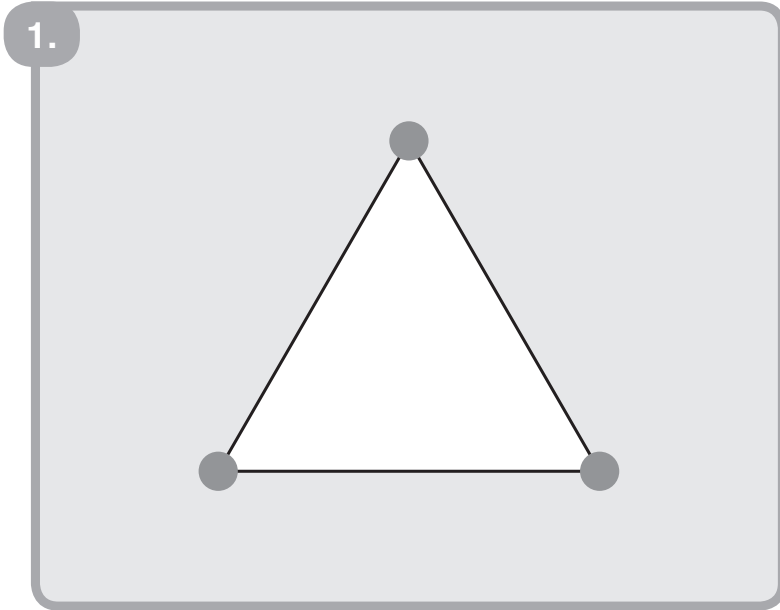

Colorea los lados.

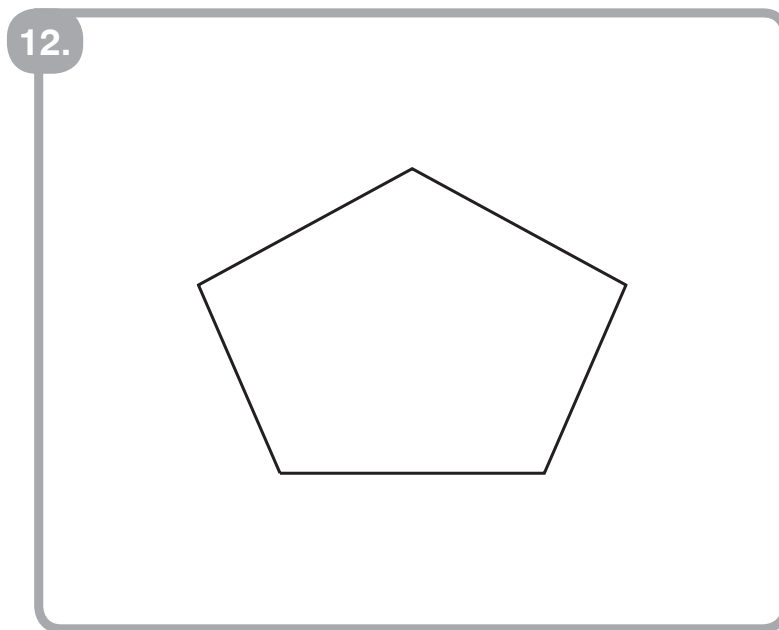
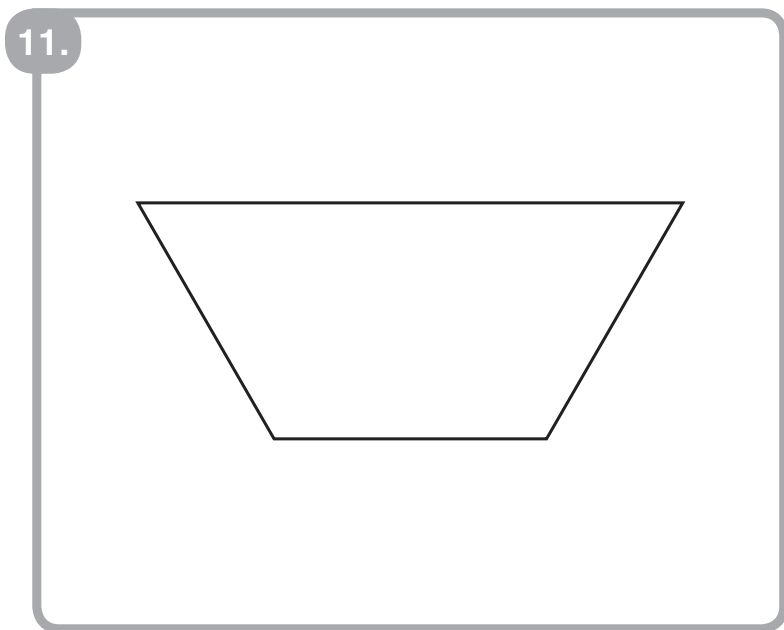
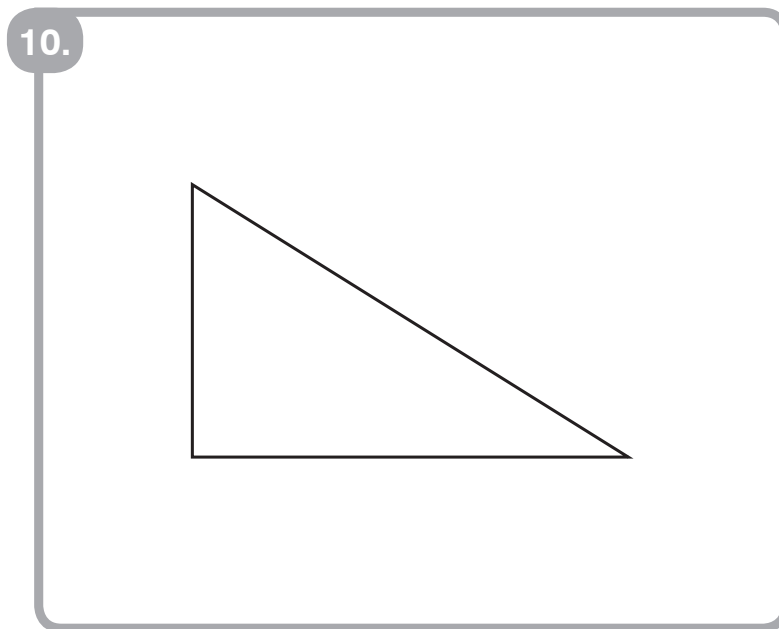
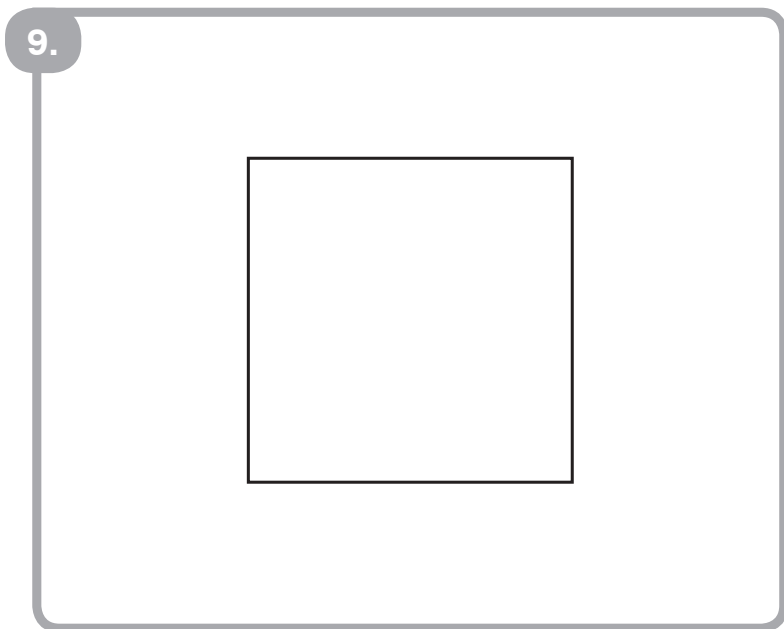
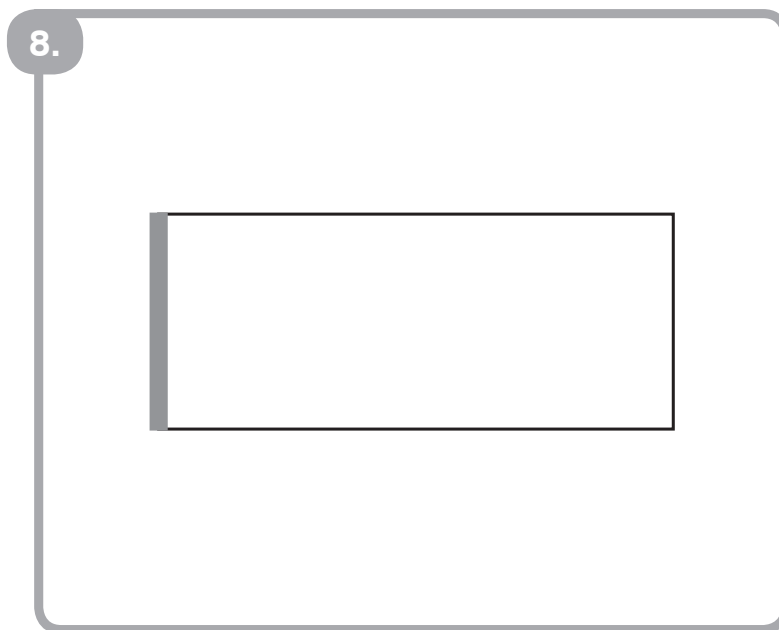
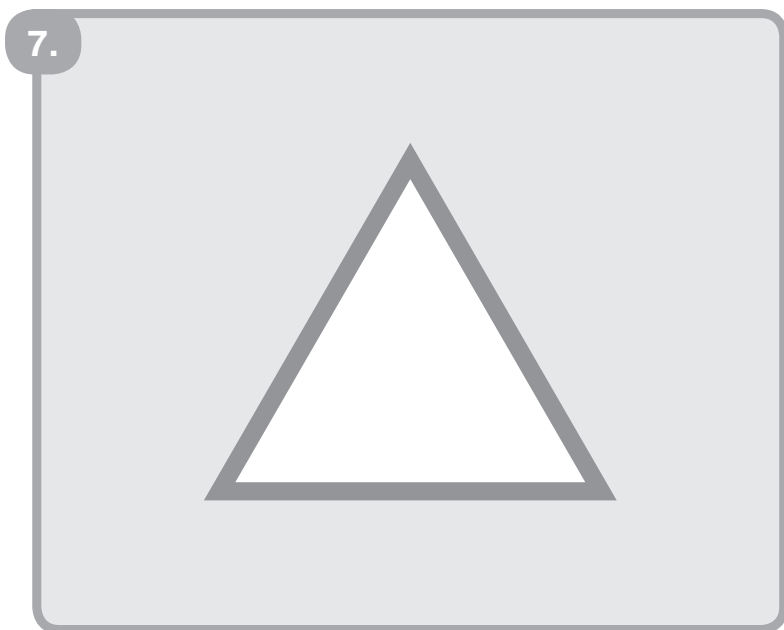

COPYRIGHT © 2017 JUMP MATH: PROHIBIDA LA REPRODUCCIÓN. EDICIÓN EN ESPAÑOL

GIInf-6 Contar esquinas y lados

Dibuja ● en cada esquina.

Cuenta las esquinas.

1.



1 2 3 4 5

2.

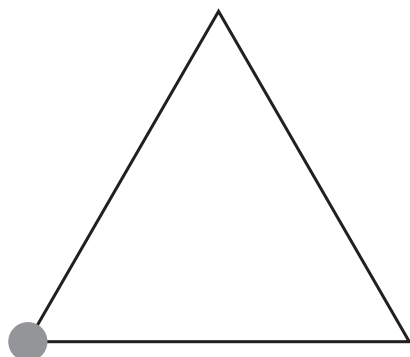

1 2 3 4 5

3.

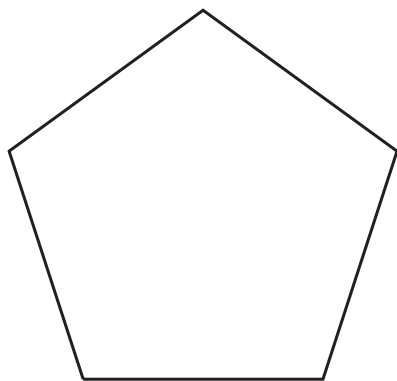

1 2 3 4 5

Dibuja ● en cada esquina.

Cuenta las esquinas.

4.

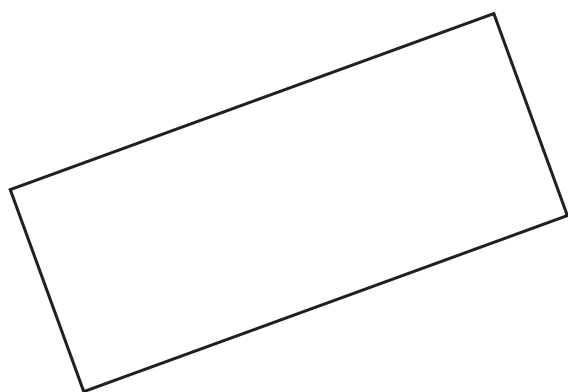

1 2 3 4 5

5.

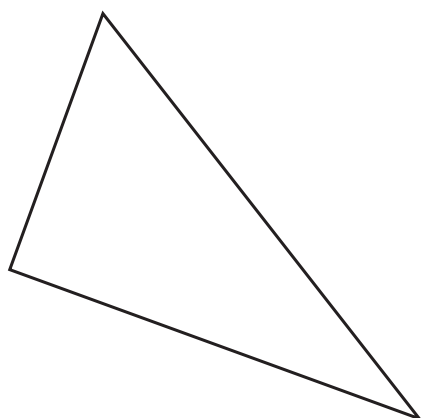

1 2 3 4 5

6.

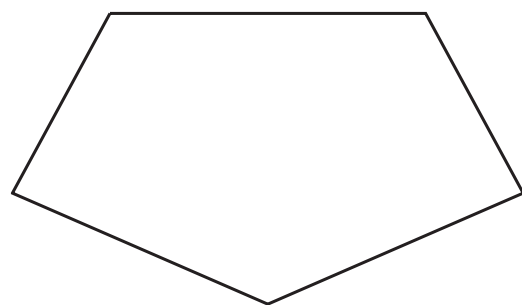

1 2 3 4 5

Colorea los lados.

Cuenta los lados.

7.



1 2 ③ 4 5

8.

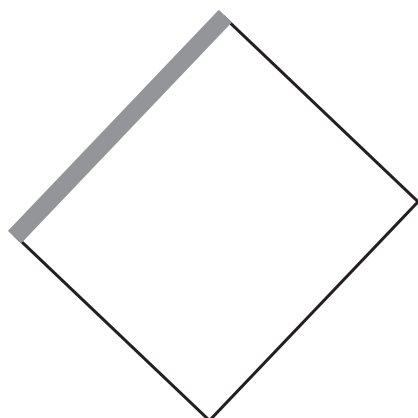

1 2 3 4 5

9.

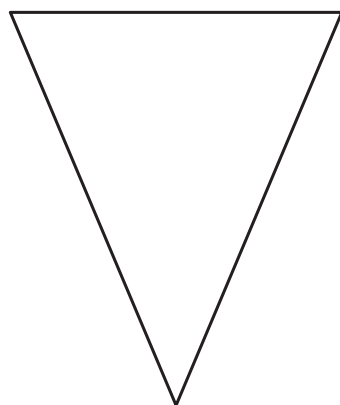

1 2 3 4 5

Colorea los lados.

Cuenta los lados.

10.

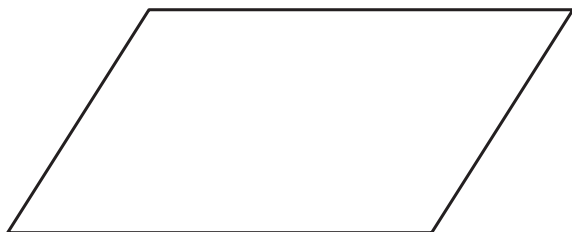

1 2 3 4 5

11.

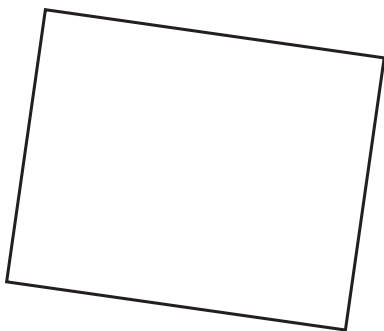

1 2 3 4 5

12.

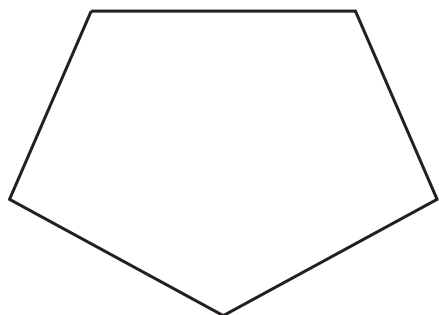

1 2 3 4 5

Inf-7 Más cuadrados y rectángulos

Cuenta los .

1.

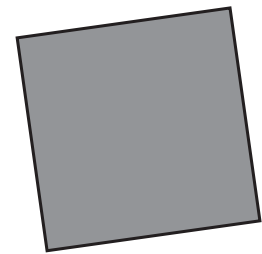
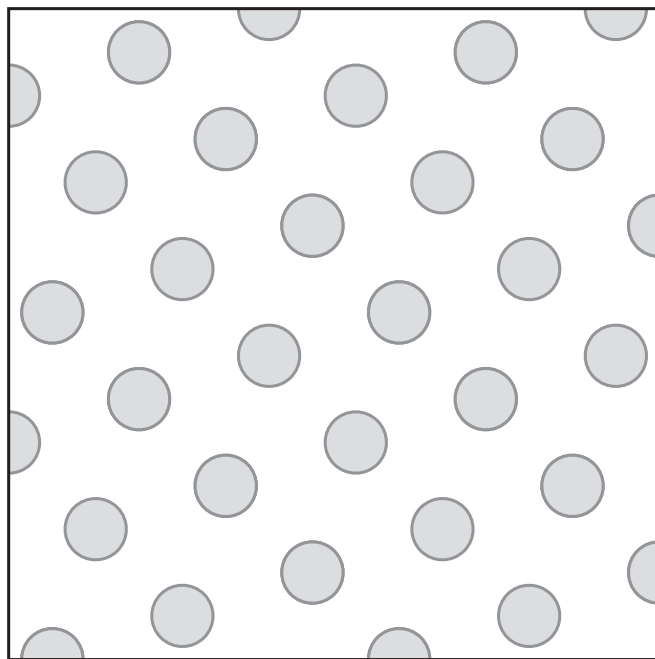
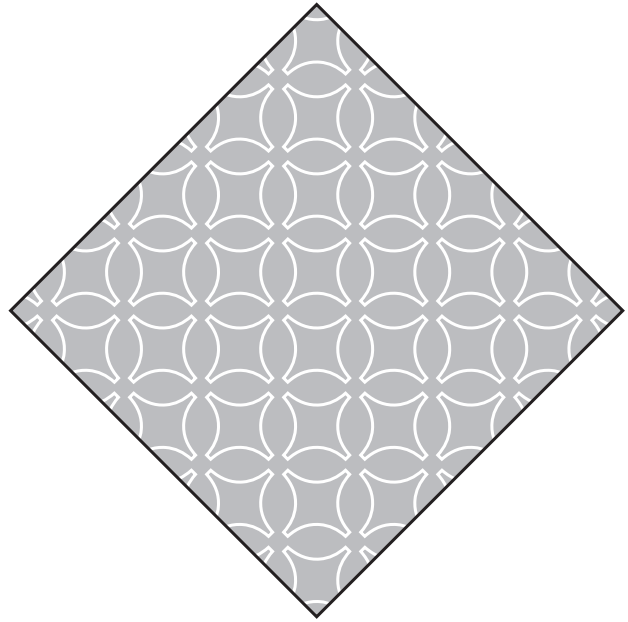
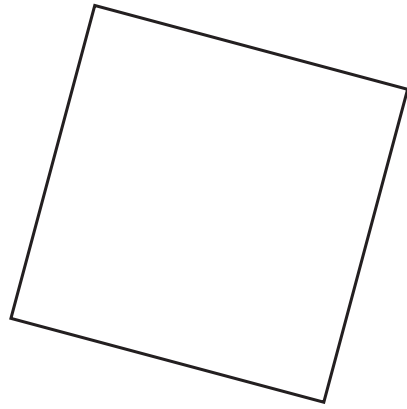

1

2

3

4

5

Colorea los .

Dibuja  en las otras figuras.

2.

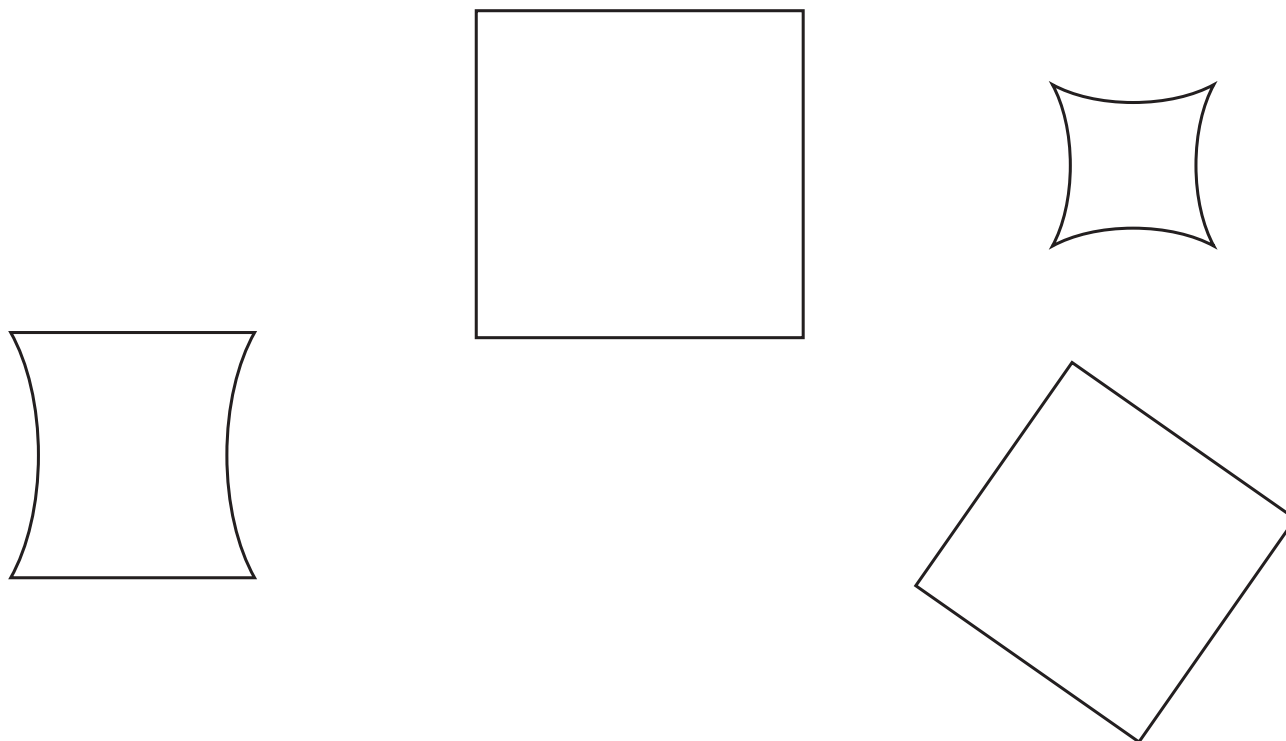

3.

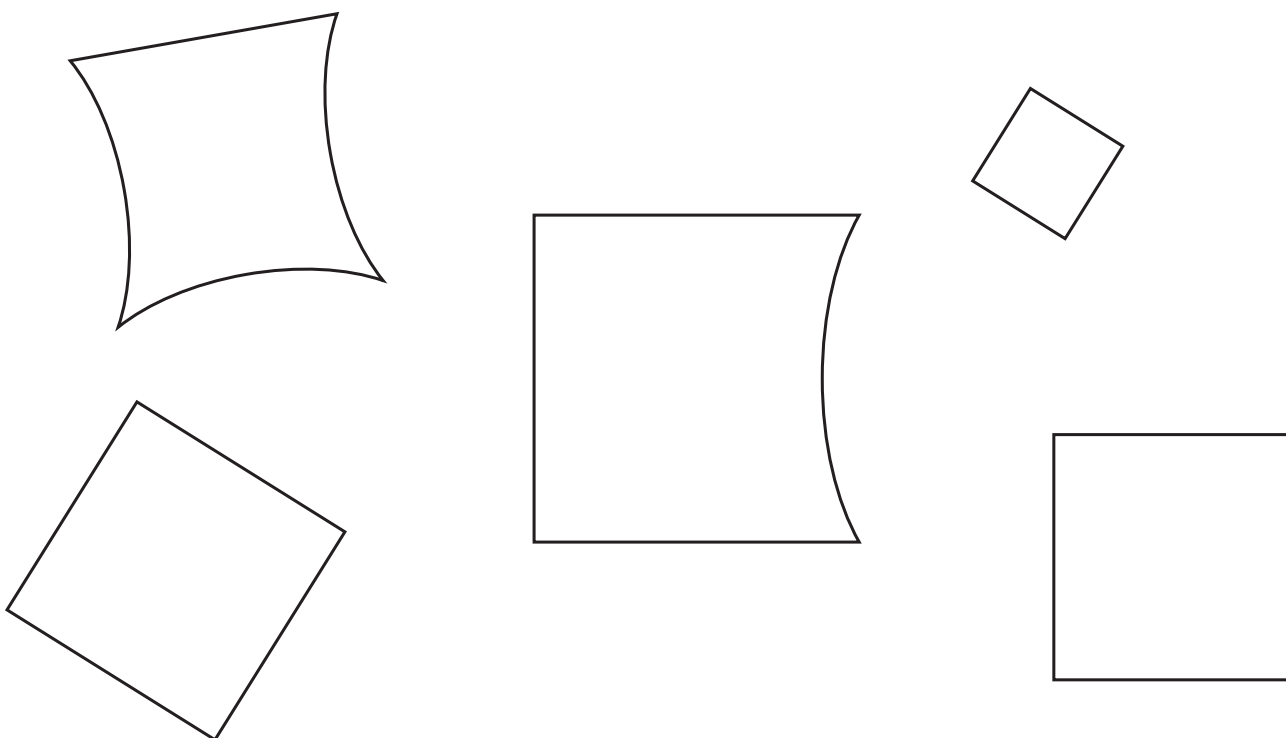

Cuenta los .

4.

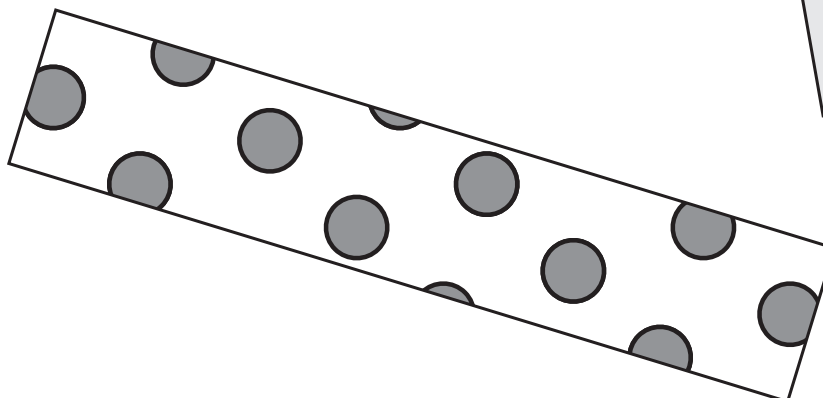
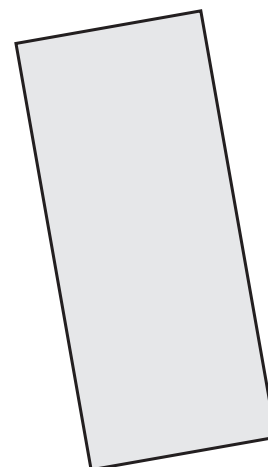
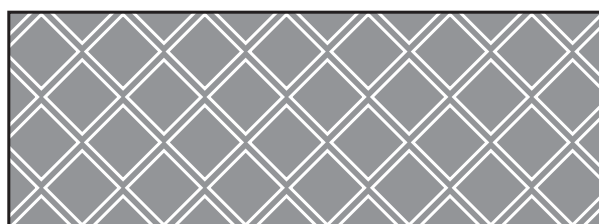
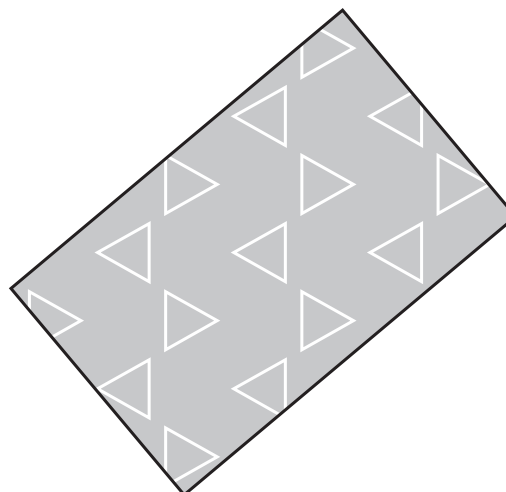
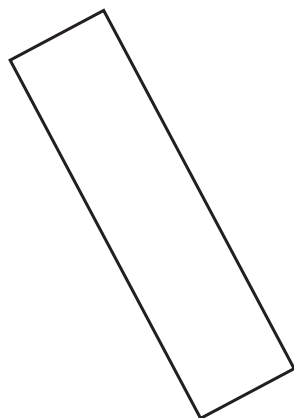

1

2

3

4

5

Colorea los .

Dibuja  en las otras figuras.

5.

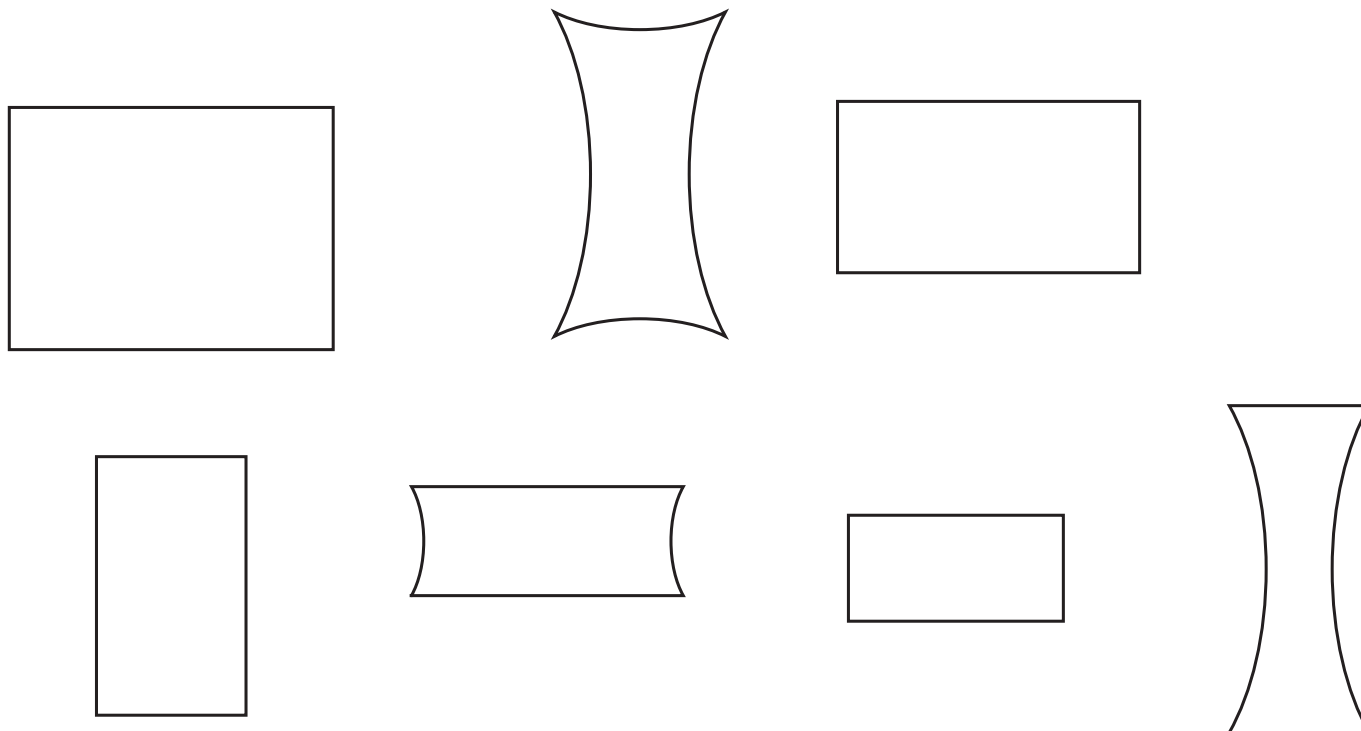

6.

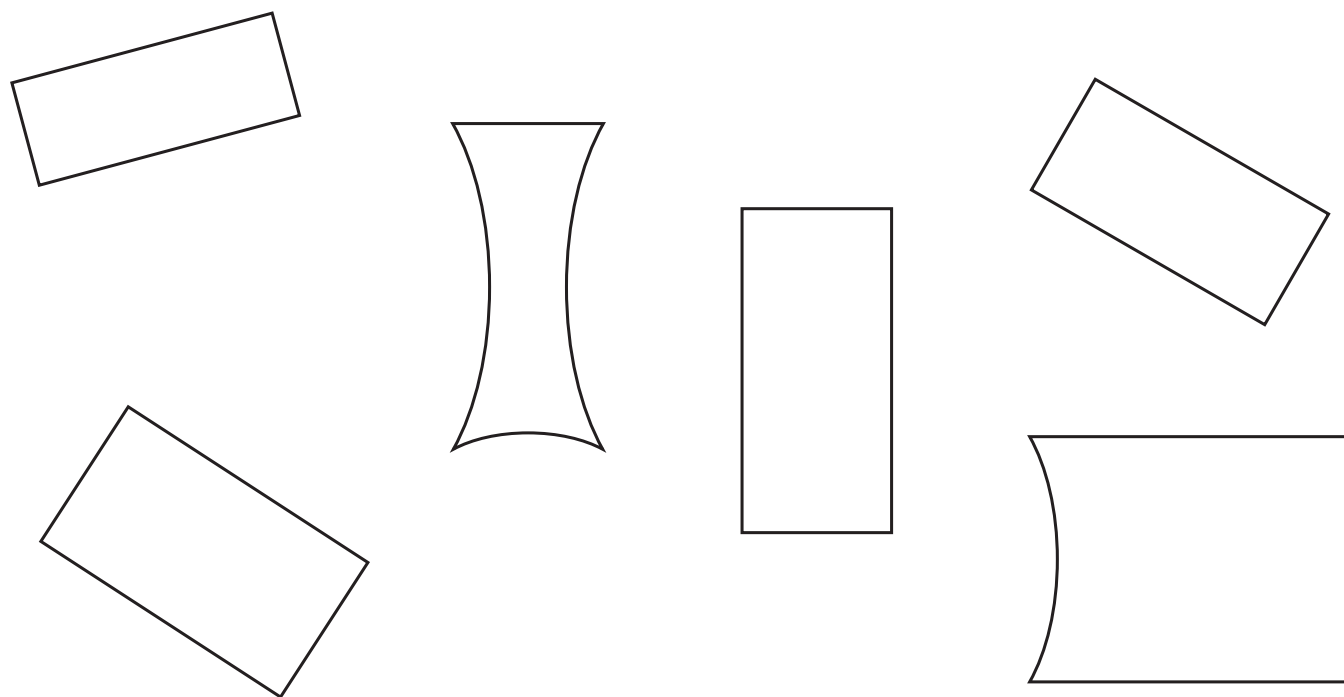

GInf-8 Triángulos

Cuenta los .

1.

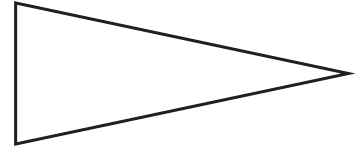
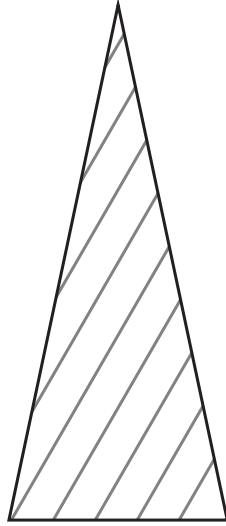
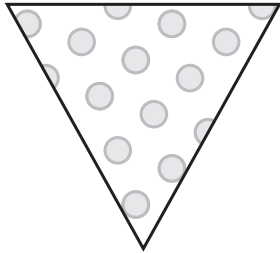
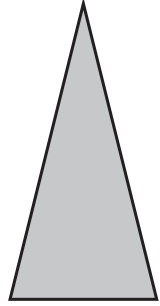

1

2

3

4

5

2.

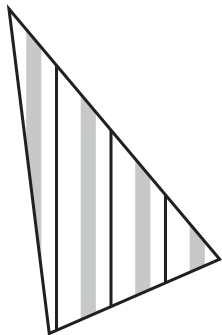
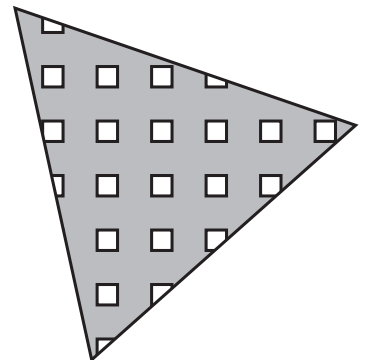
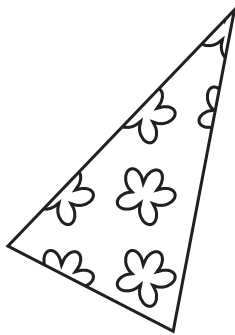
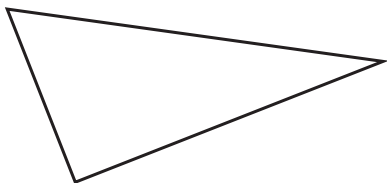

1

2

3

4

5

Colorea los \triangle .

Dibuja \times en las otras figuras.

3.

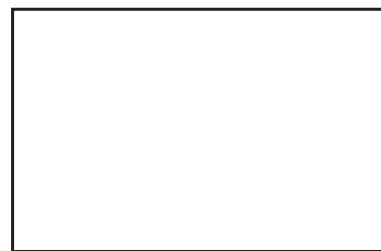
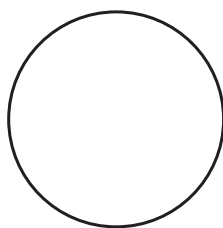
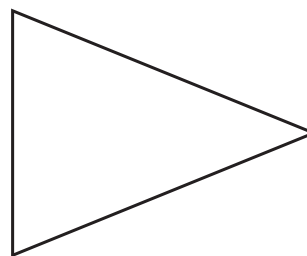
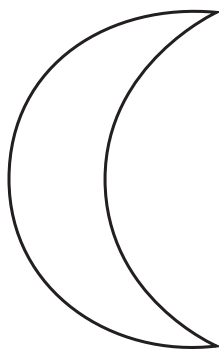
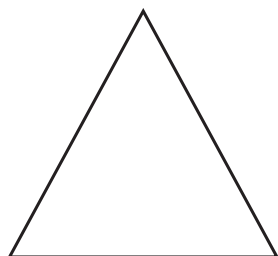

4.

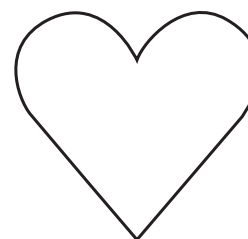
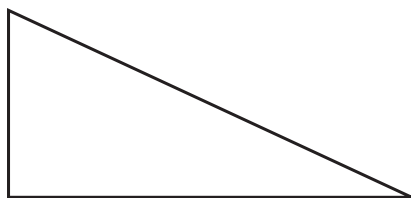
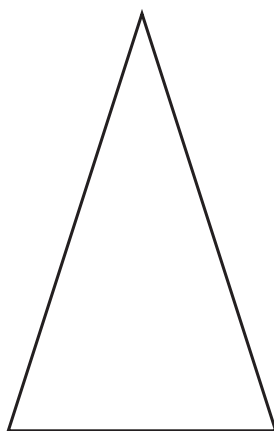
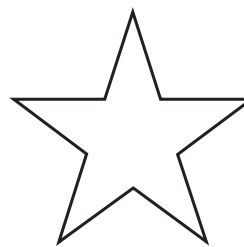
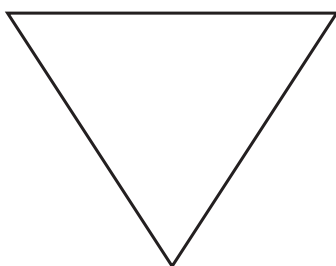
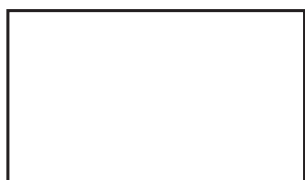

- Colorea los \triangle .
- Dibuja \times en las otras figuras.

5.

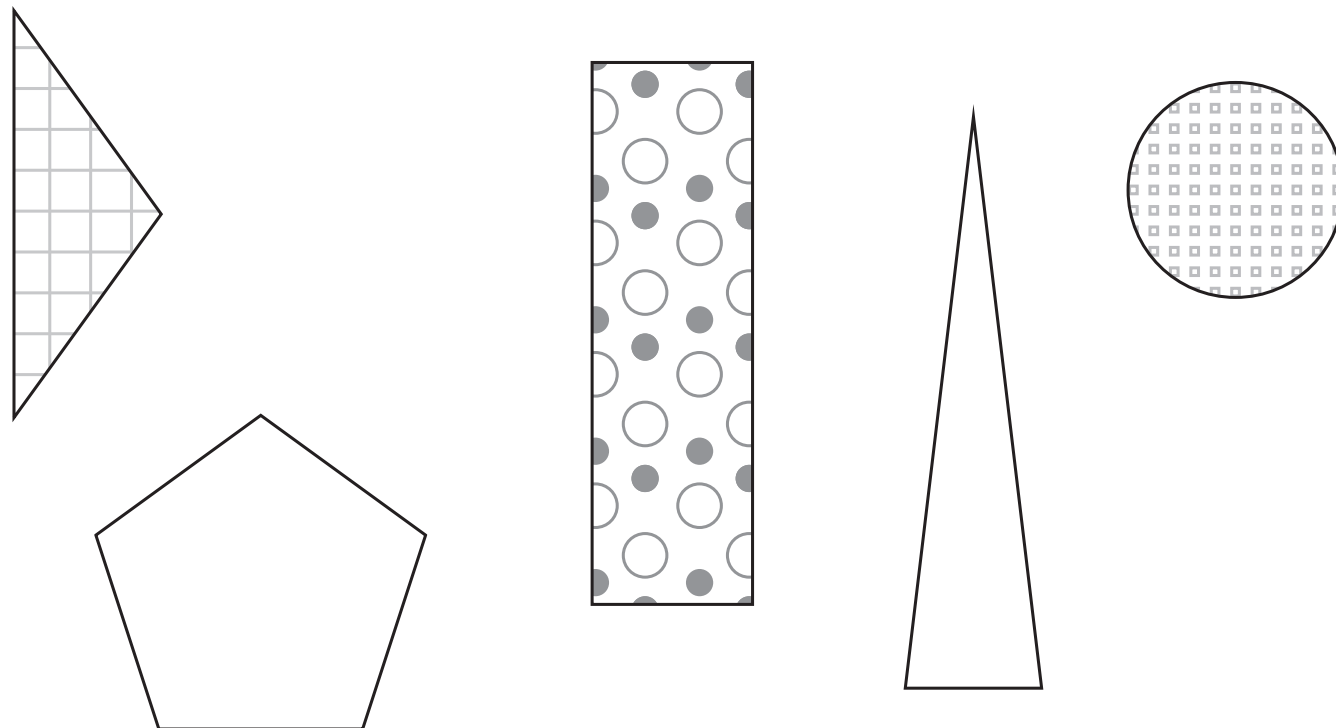

6.

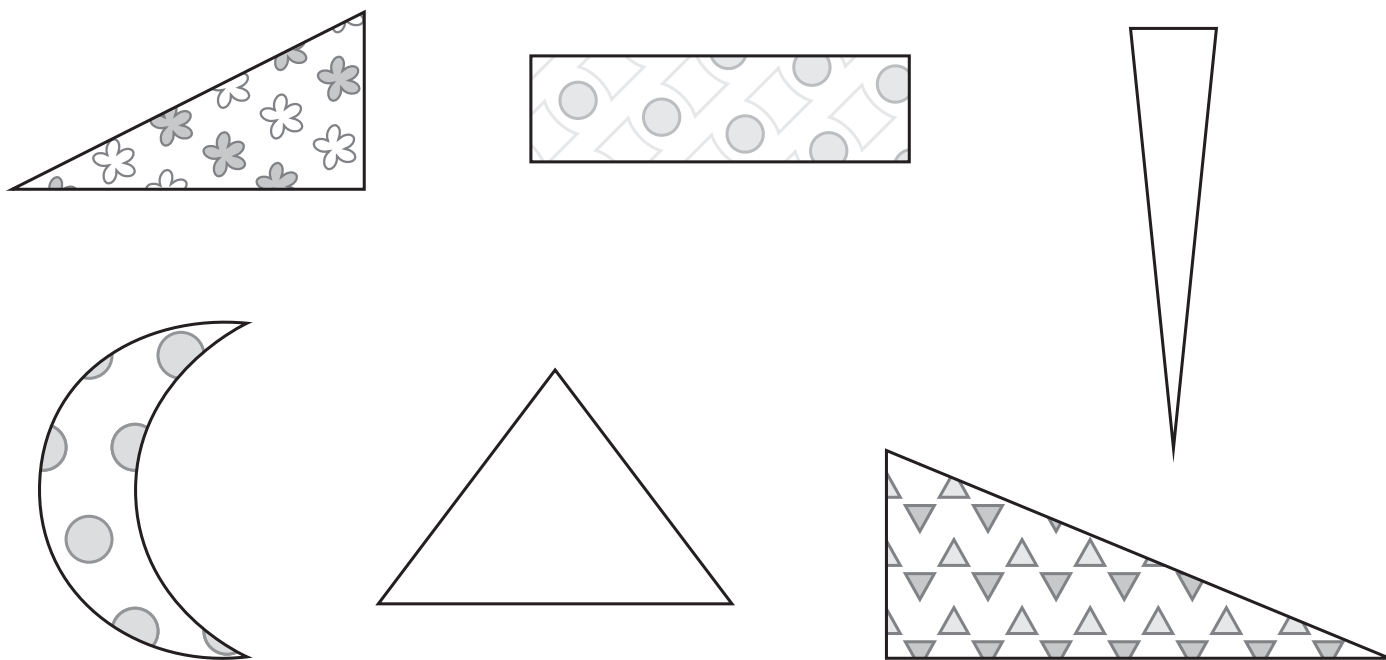

GInf-9 Describir y comparar figuras

Rodea las figuras que tienen la **misma** forma.

1.

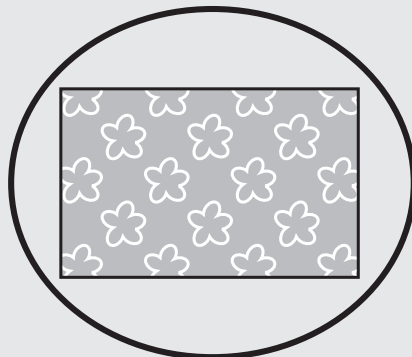
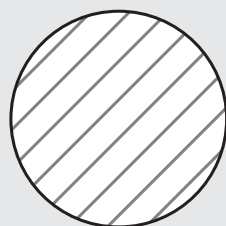
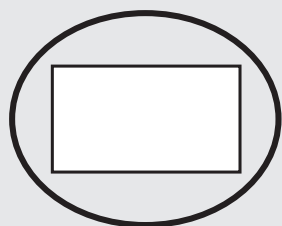

2.

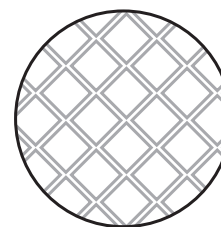
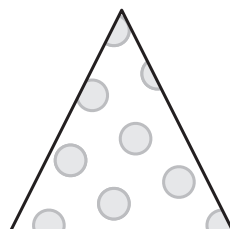
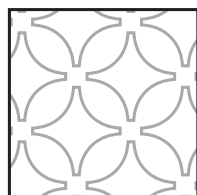

3.

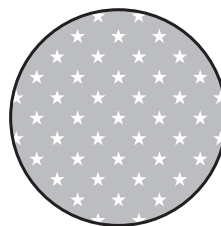
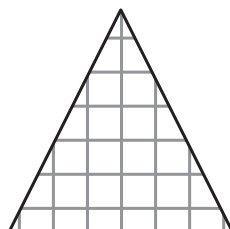
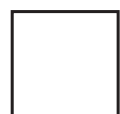

Rodea las figuras que tienen la **misma** forma.

4.

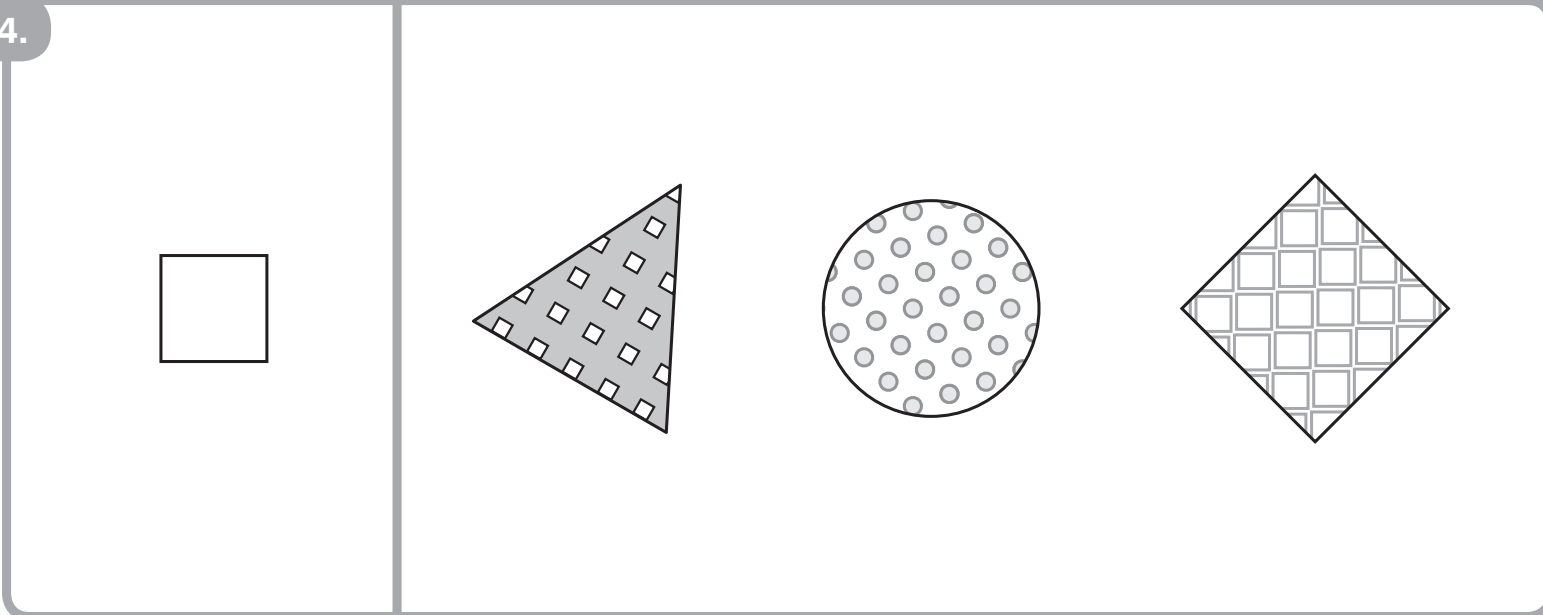

This exercise shows a reference square on the left. To its right are three options: a triangle filled with a grid of small squares, a circle filled with small circles, and a diamond filled with a grid of squares.

5.

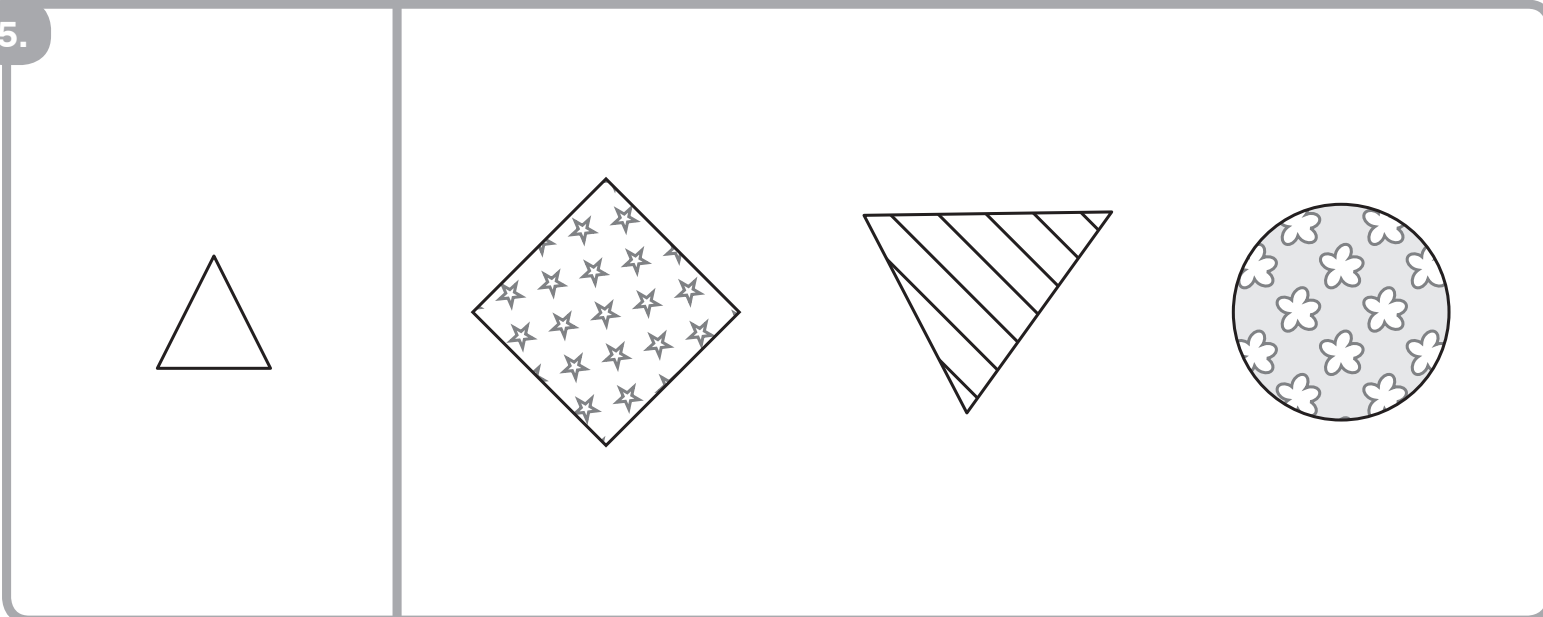

This exercise shows a reference triangle on the left. To its right are three options: a diamond filled with small stars, a triangle filled with diagonal lines, and a circle filled with small flowers.

6.

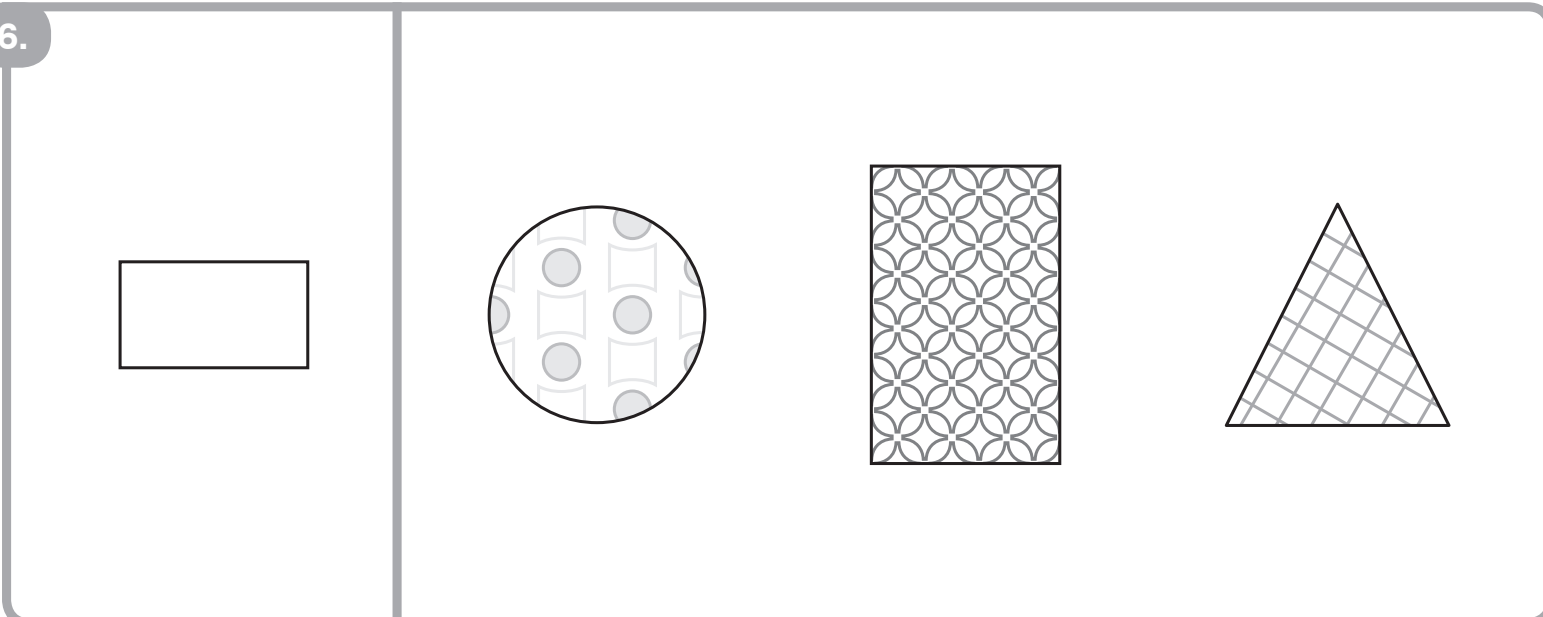

This exercise shows a reference rectangle on the left. To its right are three options: a circle filled with a pattern of small circles and rectangles, a rectangle filled with a pattern of overlapping circles, and a triangle filled with a grid of squares.

GInf-10 Figuras abiertas y figuras cerradas

- Colorea las **figuras cerradas**.
- Dibuja una **X** en las **figuras abiertas**.

1.

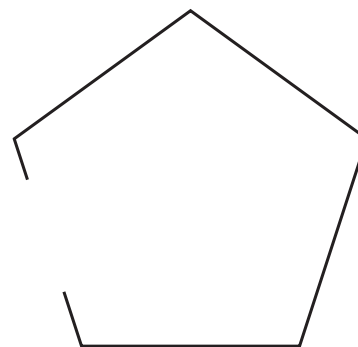
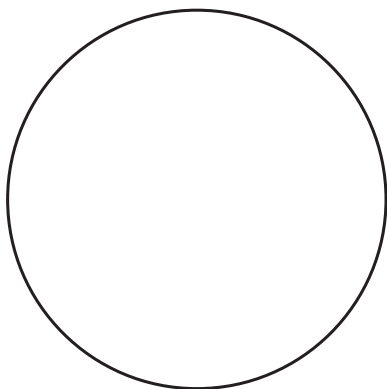
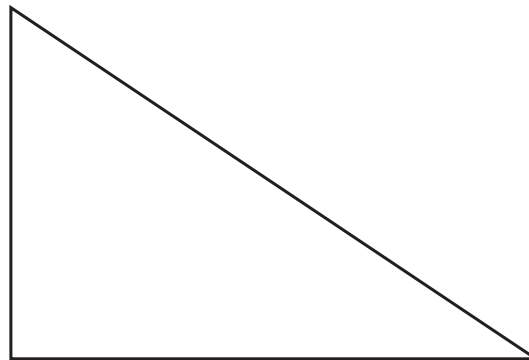
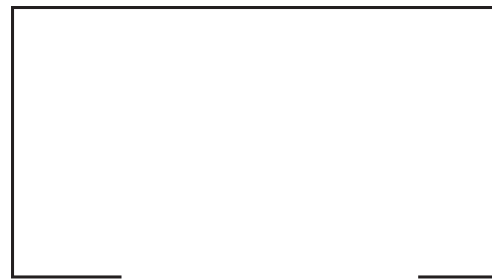
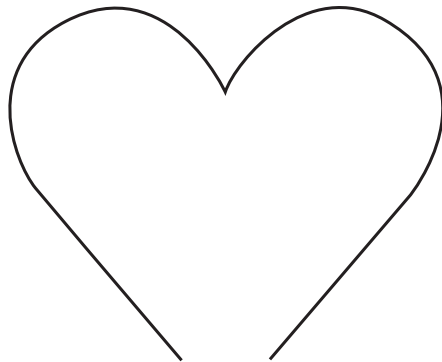
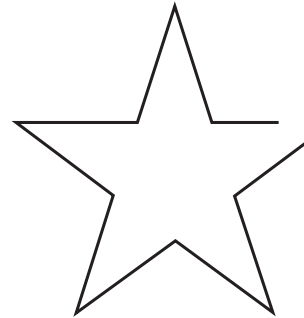
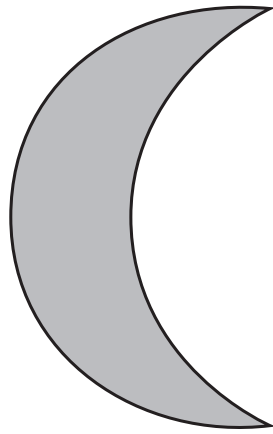
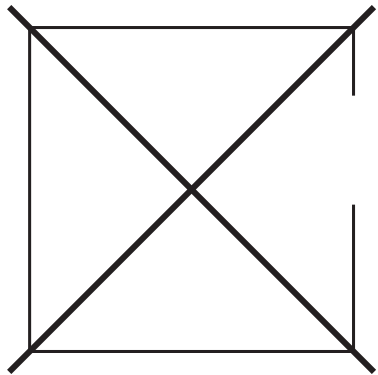

- Colorea las **figuras cerradas**.
- Dibuja una **X** en las **figuras abiertas**.

2.

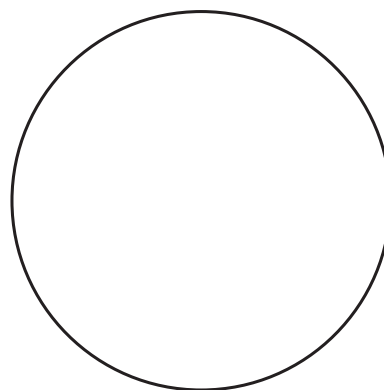
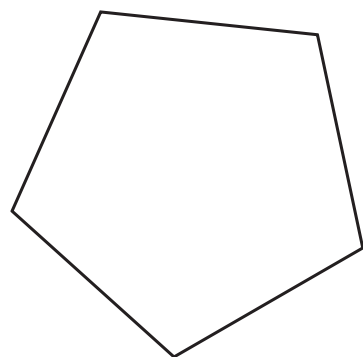
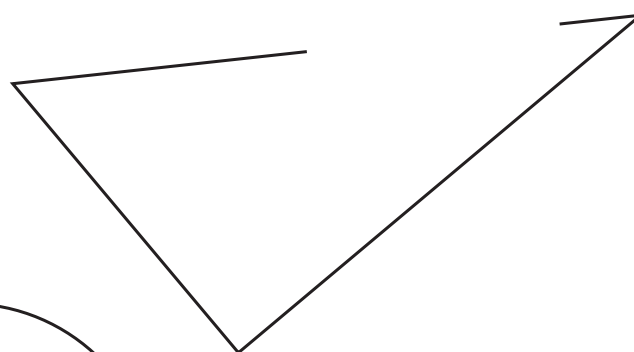
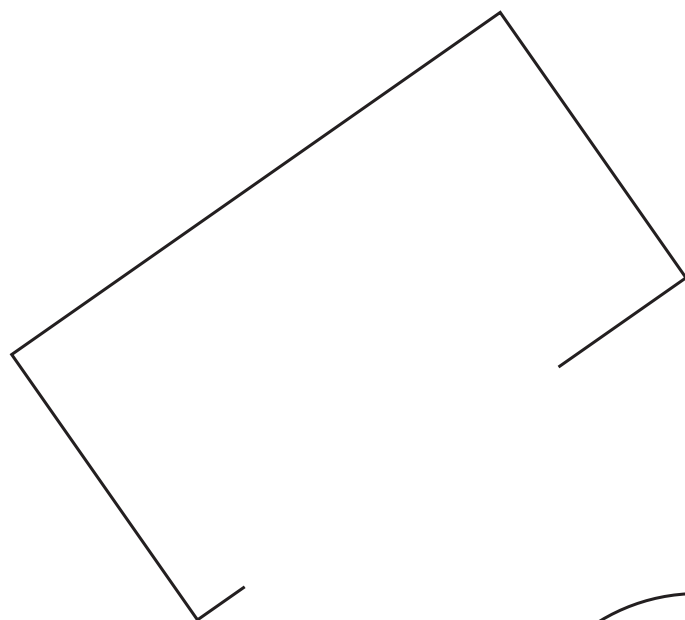
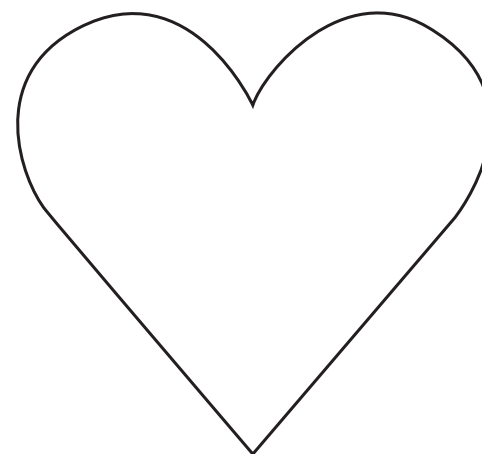
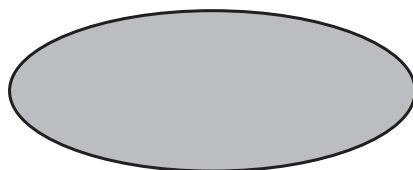
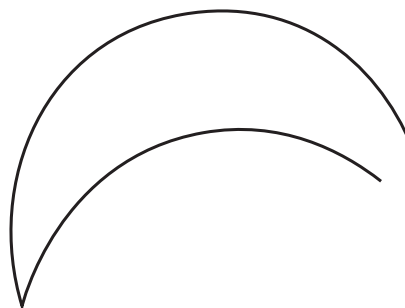
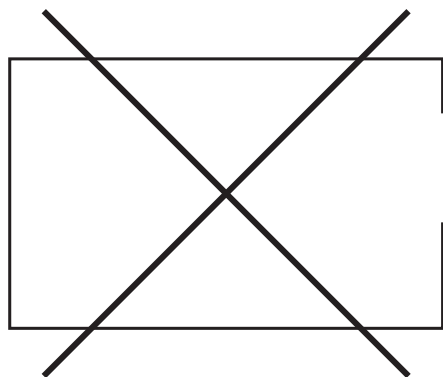

GInf-11 *Encima*

Rodea la figura que está **encima**.

1.

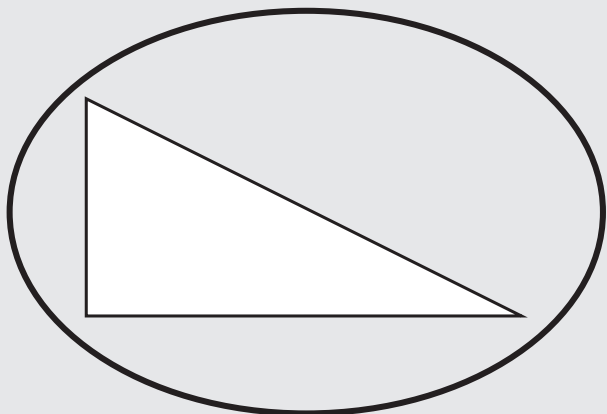

2.

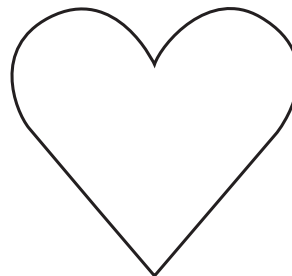

3.

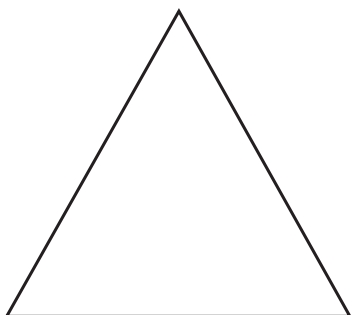
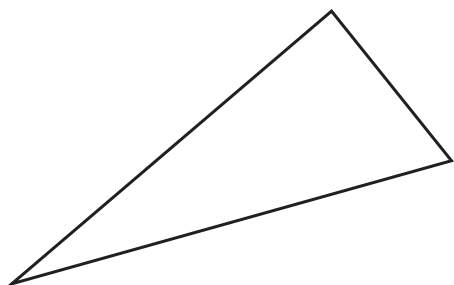

4.

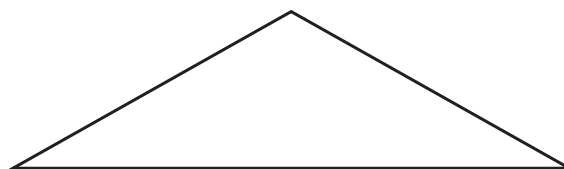
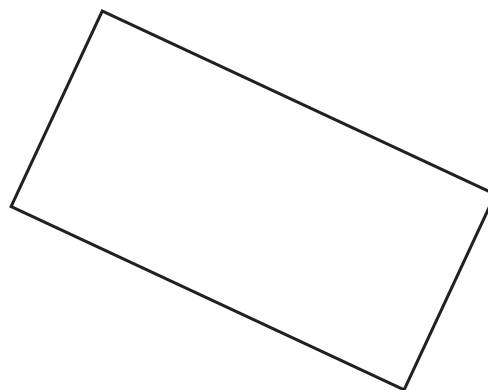

¿Cuántas figuras hay encima de la línea?

5.

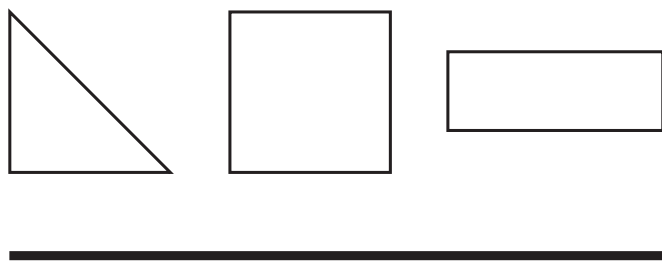

1 2 3 4 5

6.

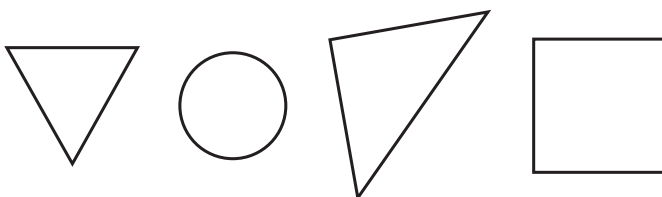

1 2 3 4 5

7.

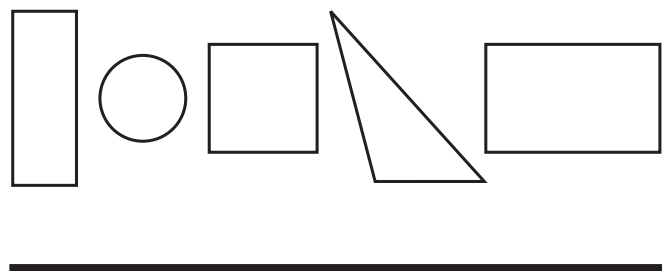

1 2 3 4 5

¿Cuántas figuras hay encima de la línea?

8.

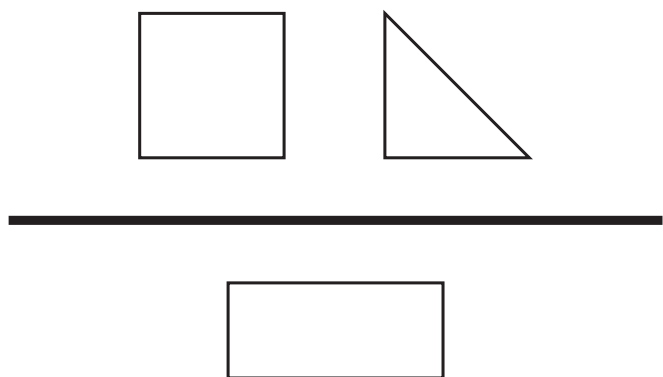

1 2 3 4 5

9.

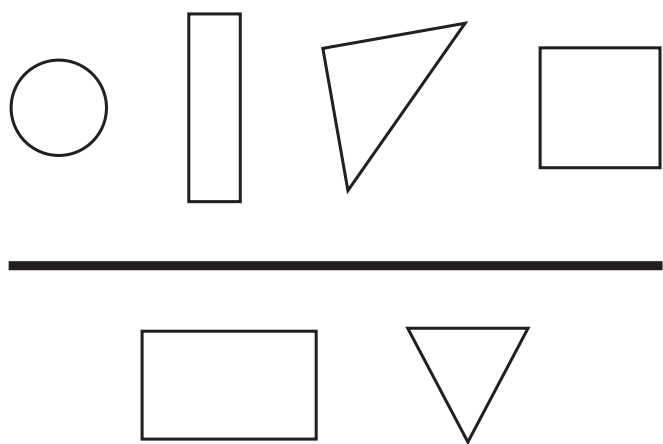

1 2 3 4 5

10.

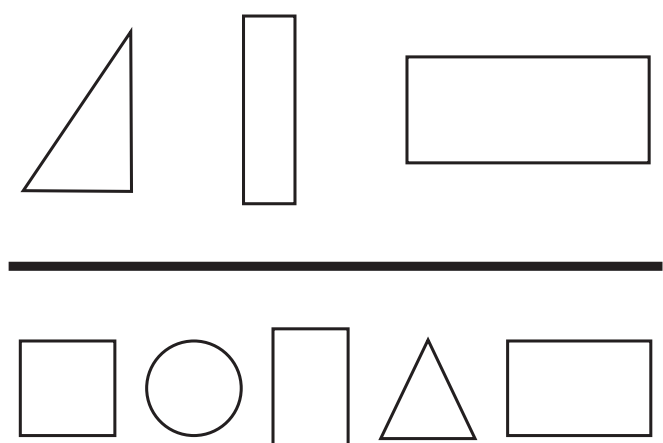

1 2 3 4 5

COPYRIGHT © 2017 JUMP MATH: PROHIBIDA LA REPRODUCCIÓN. EDICIÓN EN ESPAÑOL

GInf-12 *Debajo*

Rodea la figura que está **debajo**.

1.

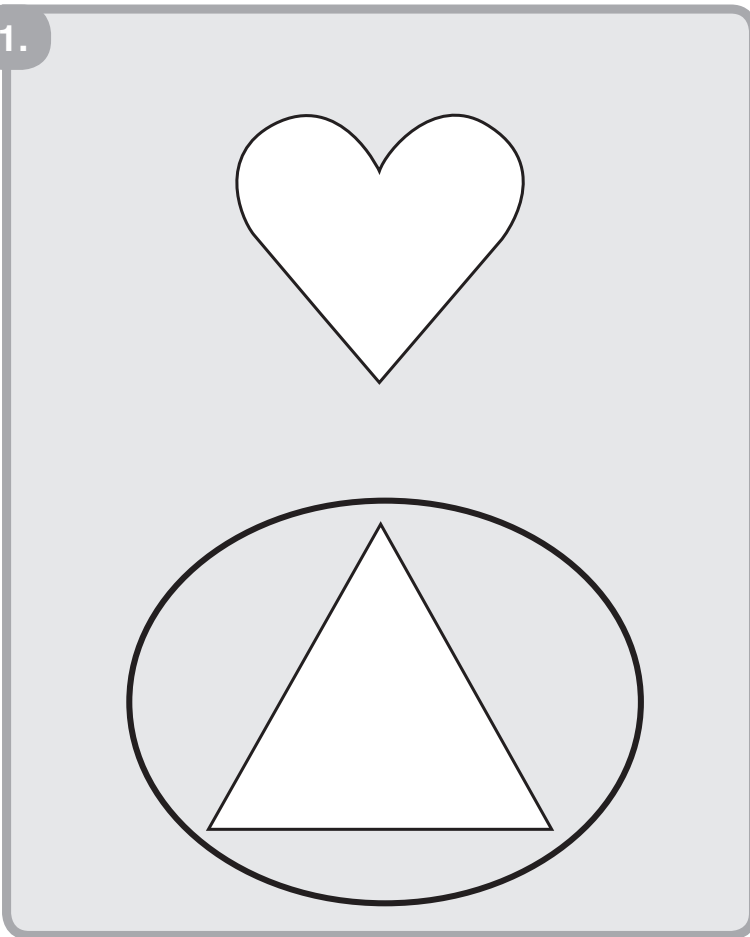

2.

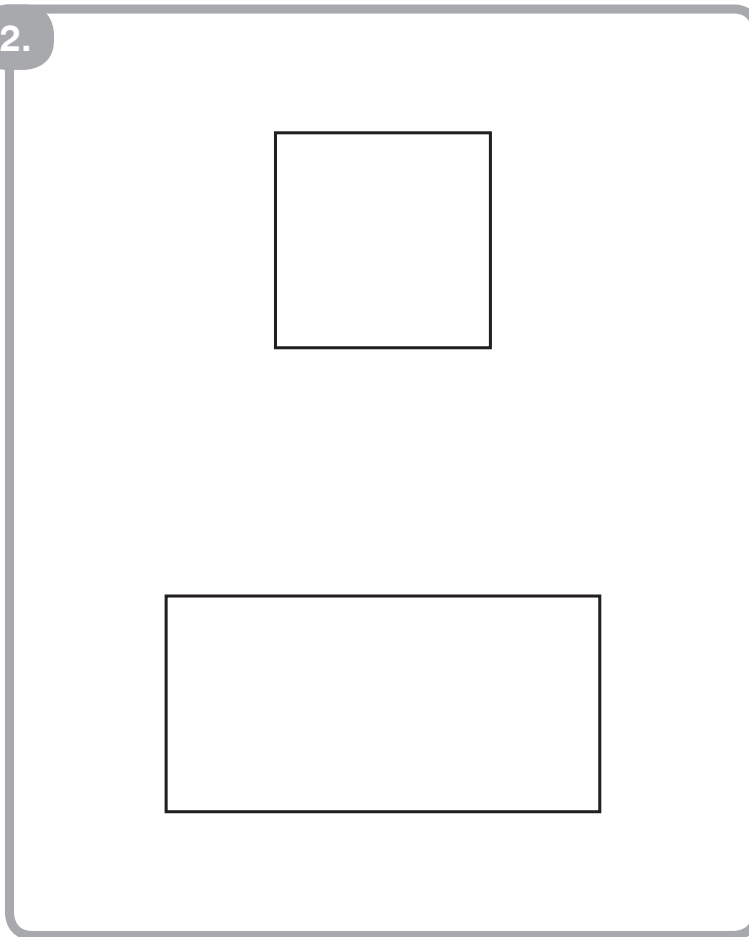

3.

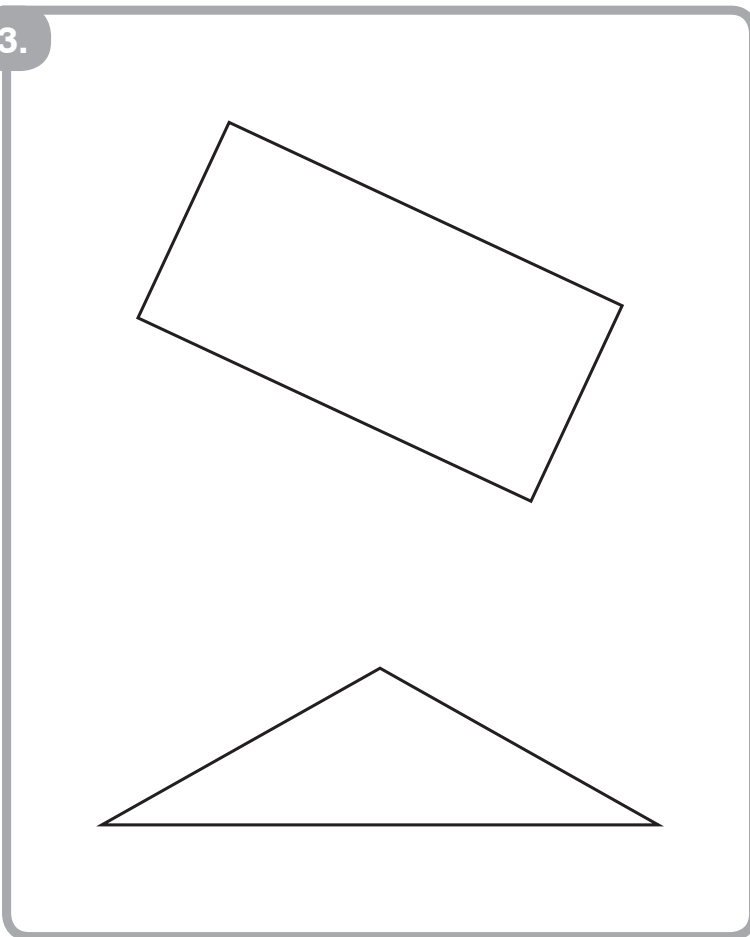

4.

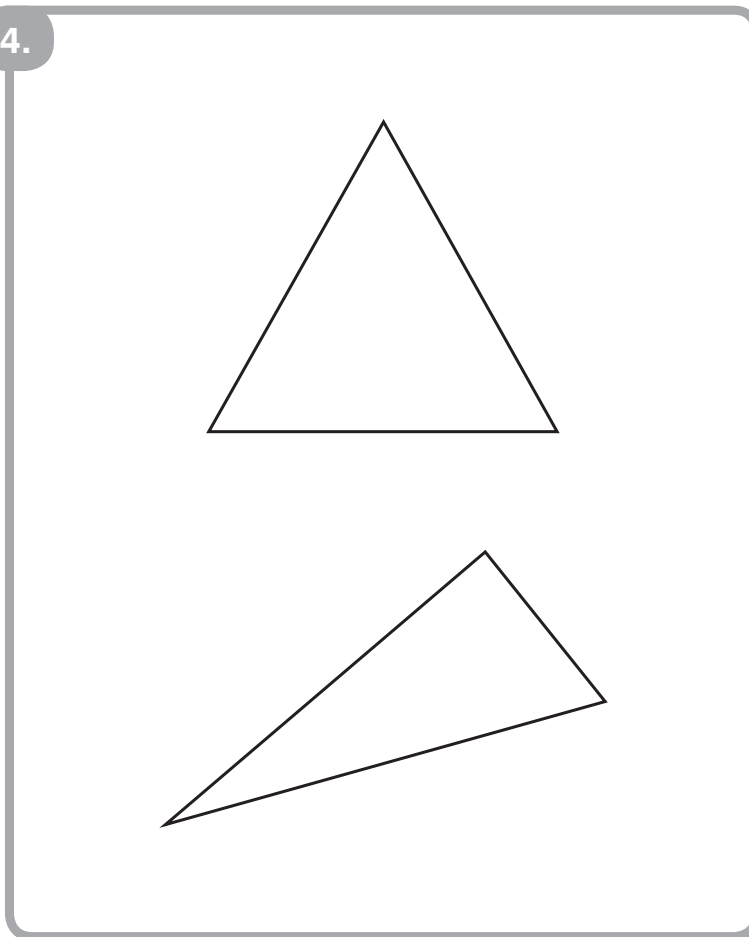

¿Cuántas figuras hay debajo de la línea?

5.



1 2 3 4 5

6.

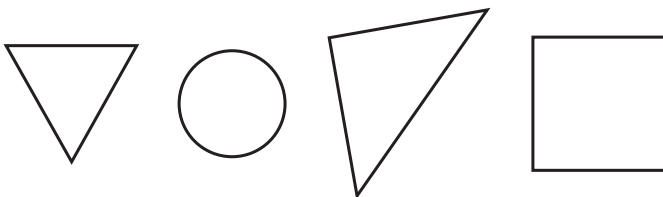

1 2 3 4 5

7.



1 2 3 4 5

¿Cuántas figuras hay debajo de la línea?

8.

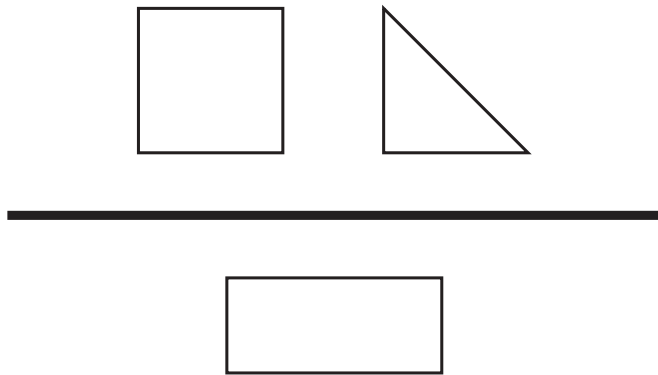

1 2 3 4 5

9.

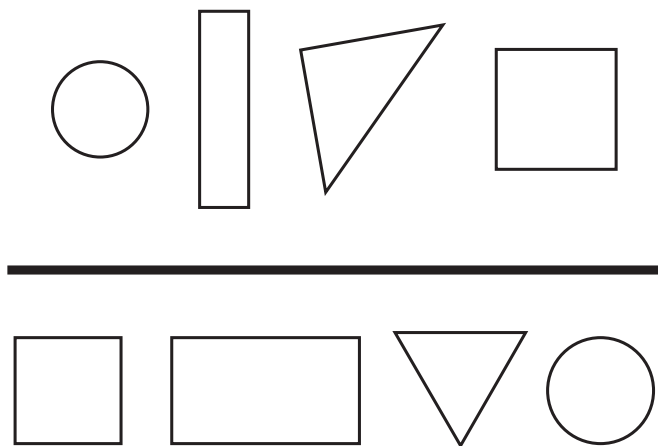

1 2 3 4 5

10.

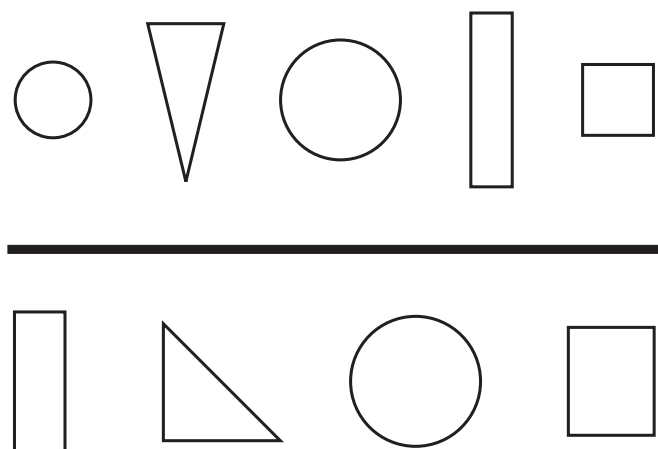

1 2 3 4 5

GInf-13 *Al lado*

Dibuja una ✕ en la figura que hay **al lado** del ○.

1.

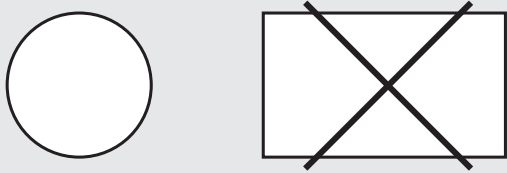

A circle is on the left and a rectangle with a large 'X' drawn across it is on the right.

2.

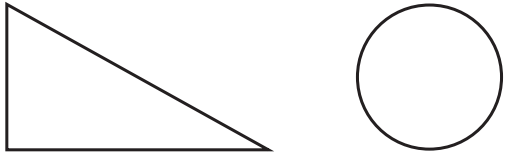

A right-angled triangle is on the left and a circle is on the right.

3.

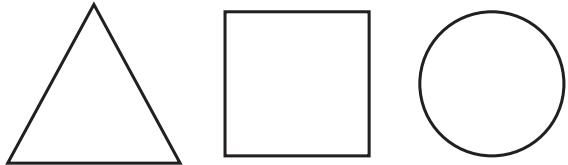

A triangle is on the left, a square is in the middle, and a circle is on the right.

4.

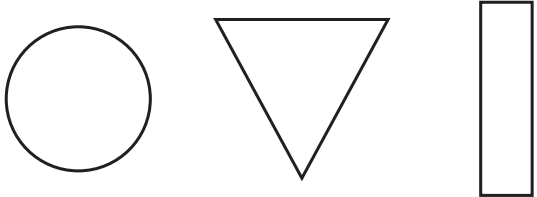

A circle is on the left, an inverted triangle is in the middle, and a vertical rectangle is on the right.

5.

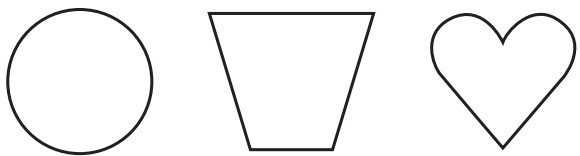

A circle is on the left, a trapezoid is in the middle, and a heart is on the right.

6.

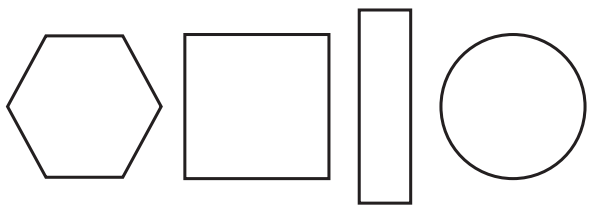

A hexagon is on the left, a square is in the middle, a vertical rectangle is to the right of the square, and a circle is on the far right.

COPYRIGHT © 2017 JUMP MATH: PROHIBIDA LA REPRODUCCIÓN. EDICIÓN EN ESPAÑOL

Dibuja una ✕ en la figura que hay al lado del ○.

7.

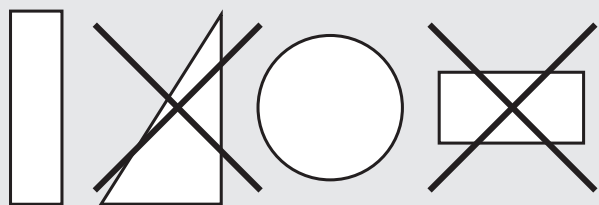

8.

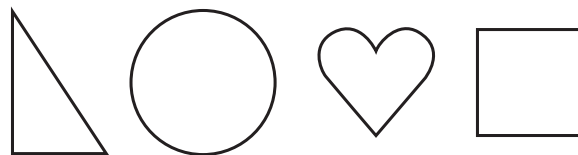

9.

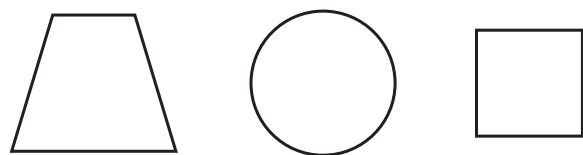

10.



11.

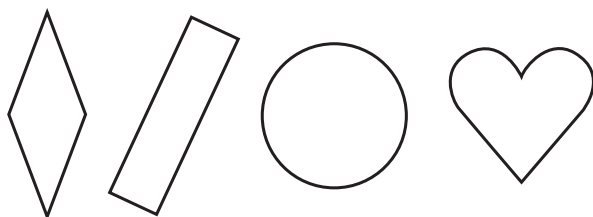

12.

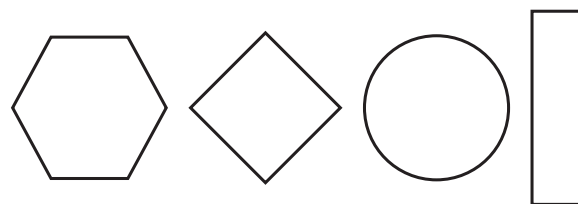

GInf-14 Componer figuras

Utiliza 2 bloques lógicos para componer la figura.

1.

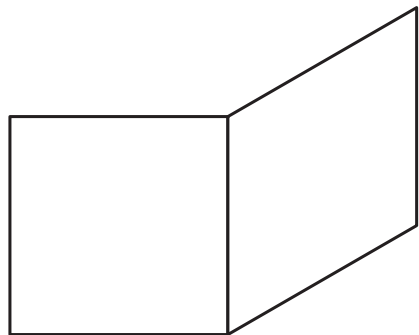

2.

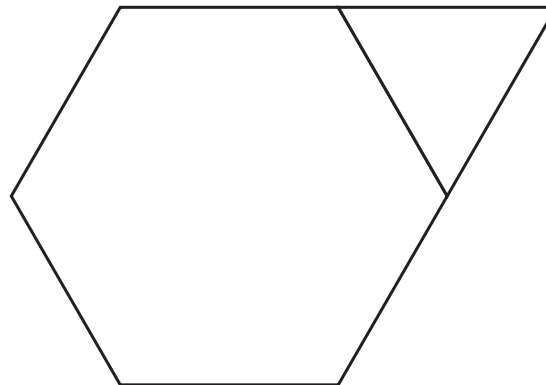

3.

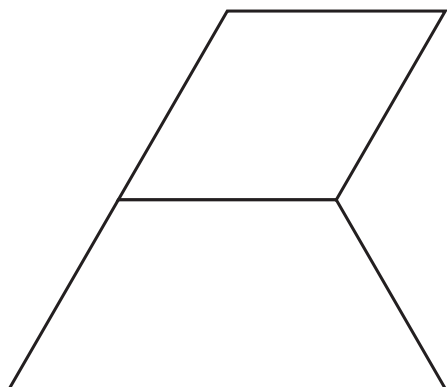

4.

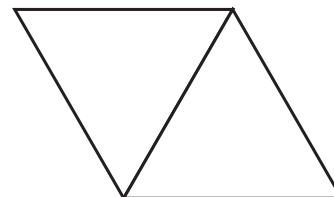

5.

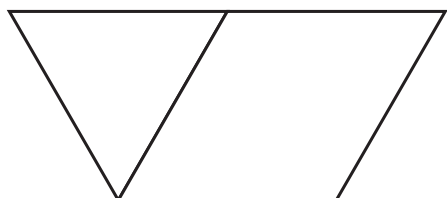

6.



Utiliza bloques lógicos para componer la figura.

7.

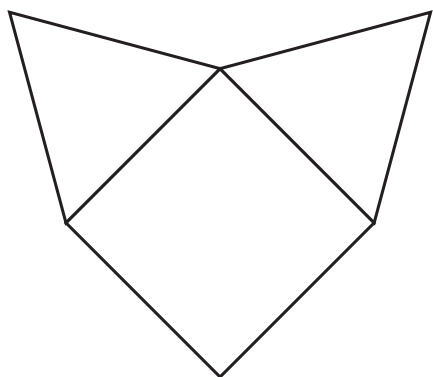

8.

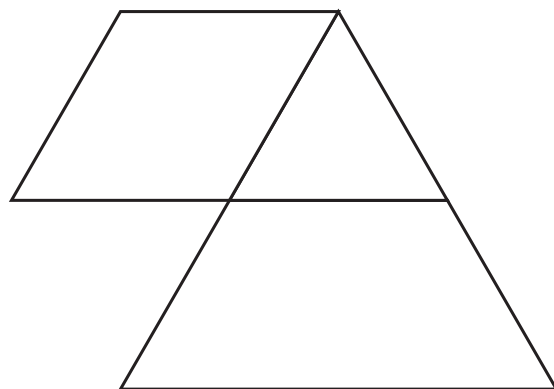

9.

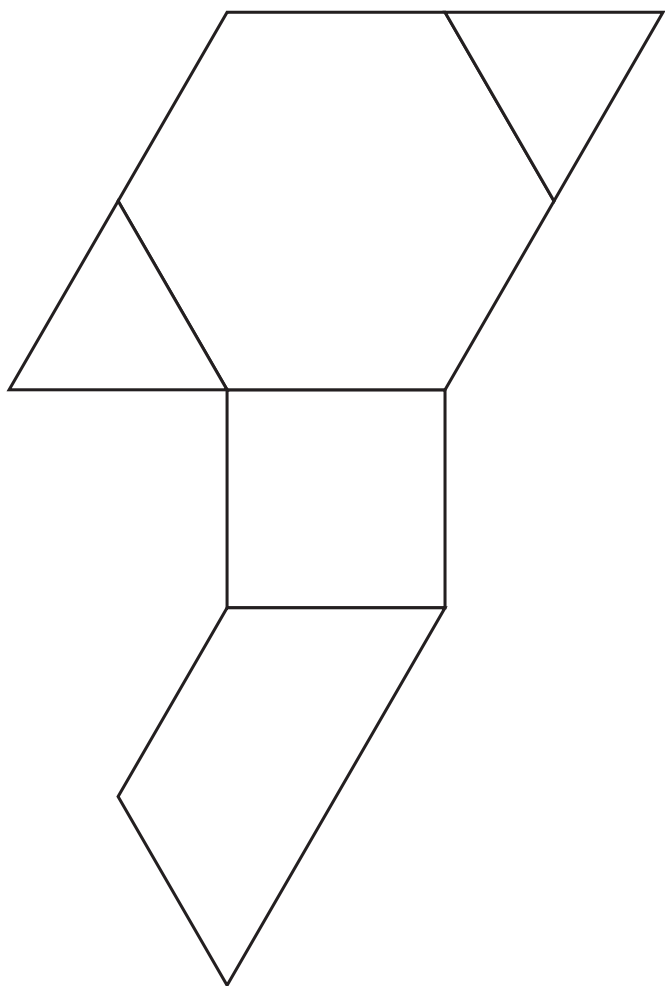

10.

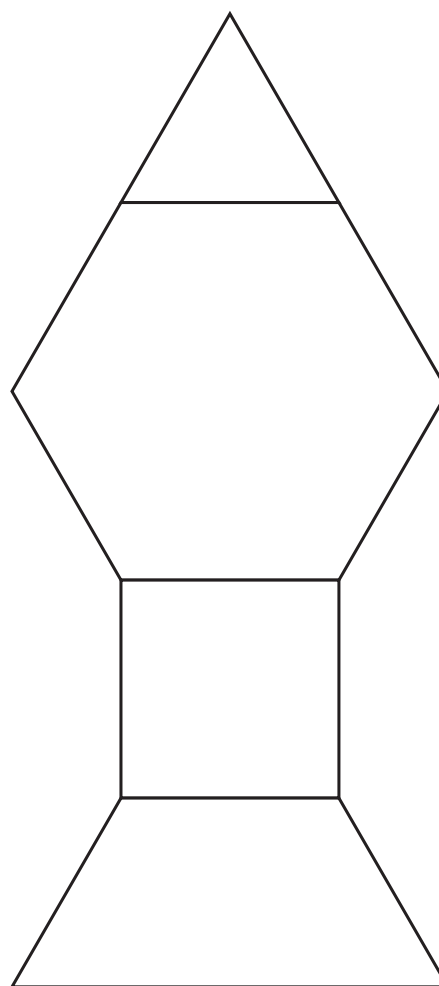

Utiliza bloques lógicos para componer la figura.

11.

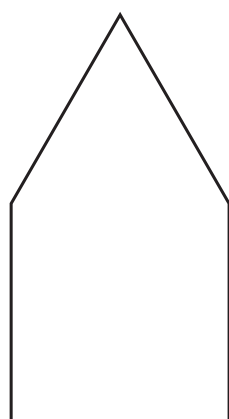

12.



13.

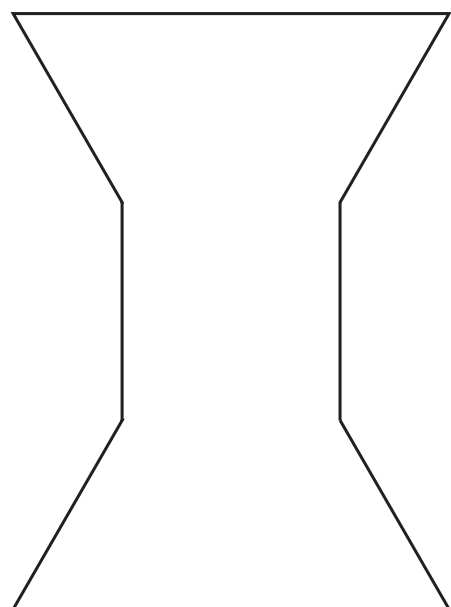

14.

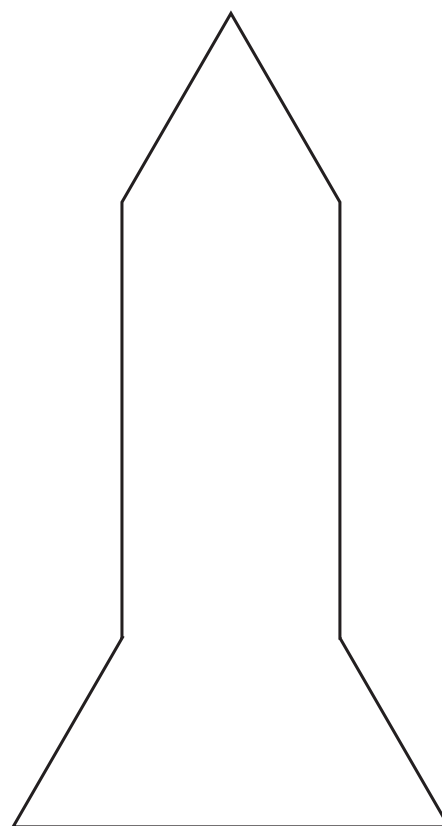

CCInf-25 Contar hasta el 40

Repasa.

1.

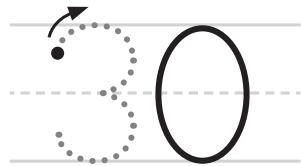
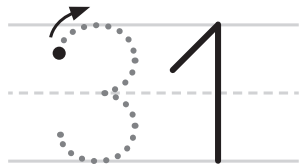
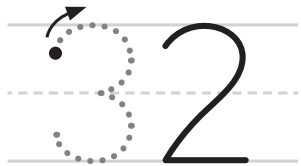
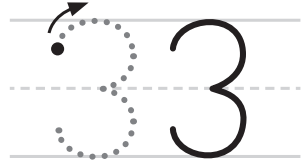
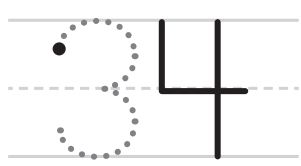
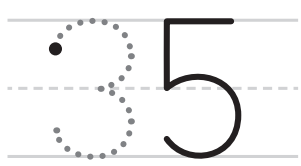
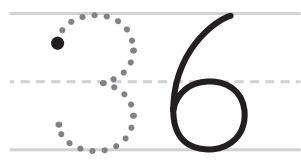
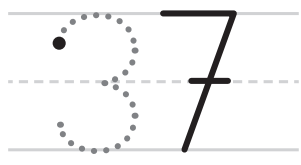
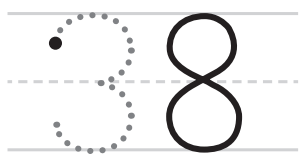
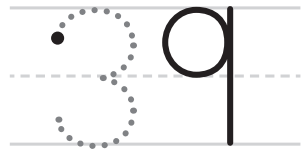
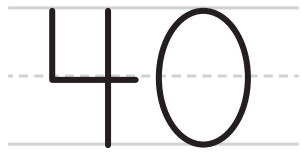
2.

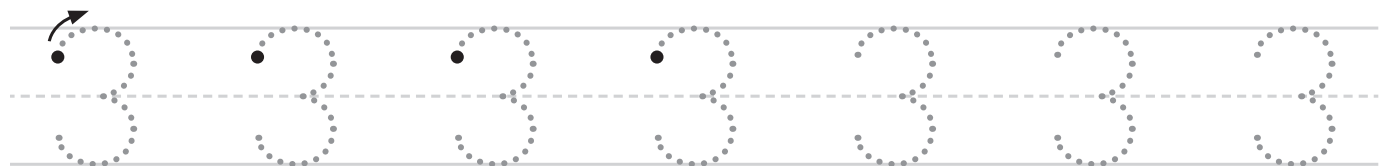

Escribe el 3.

3.

CCInf-26 Contar 6 y 7

¿Cuántos?

Cuenta. Rodea el número.

1.

1 ② 3 4 5 6 7

2.

○ ○ ○ ○ ○ ○

1 2 3 4 5 6 7

3.

□ □ □ □ □ □ □

1 2 3 4 5 6 7

4.

😊 😊 😊

😊 😊 😊

1 2 3 4 5 6 7

COPYRIGHT © 2017 JUMP MATH: PROHIBIDA LA REPRODUCCIÓN. EDICIÓN EN ESPAÑOL

¿Cuántos?

Cuenta. Rodea el número.

5.

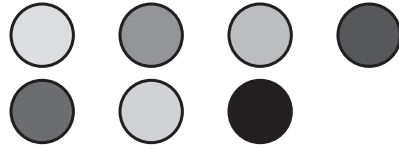

1 2 3 4 5 6 7

6.

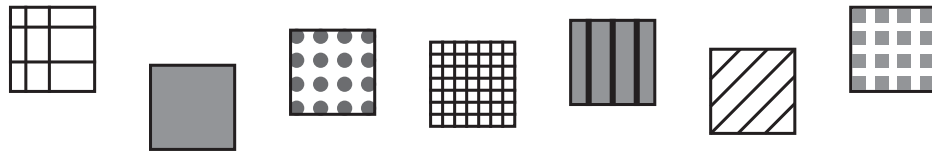

1 2 3 4 5 6 7

7.

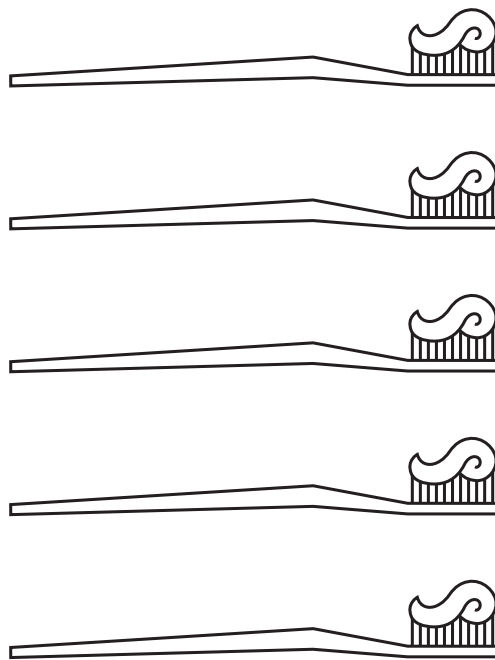

1 2 3 4 5 6 7

Cuenta y tacha.

8.

2

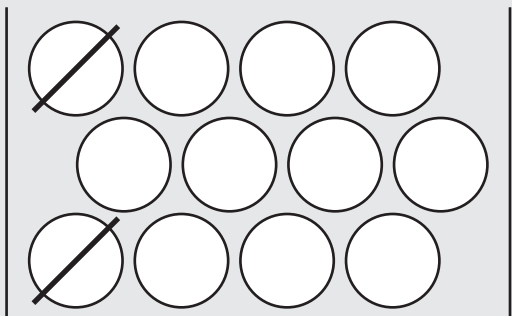

9.

5

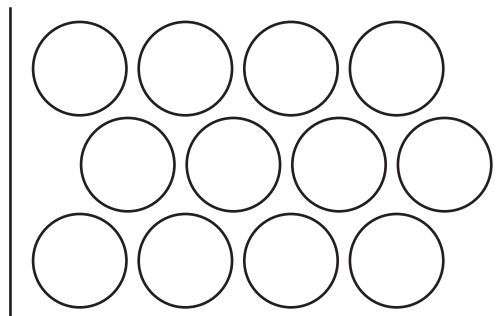

10.

3

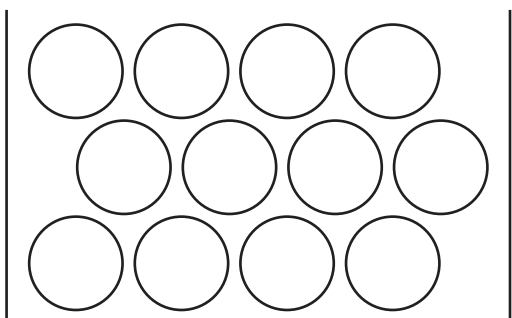

11.

6

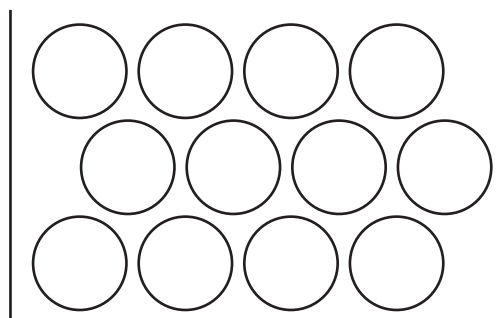

12.

7

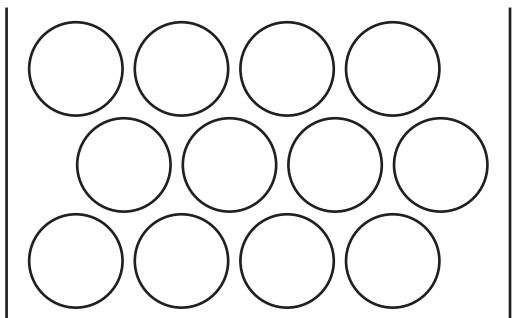

13.

4

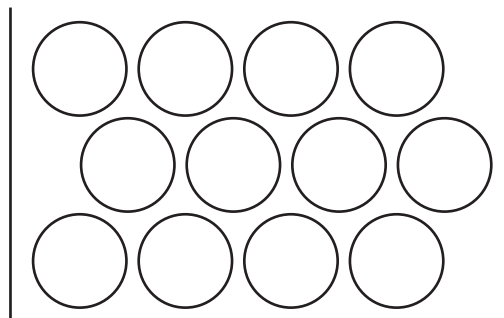

CCInf-27 Los números 6 y 7 Une con una línea.

1.



•4



•6

2.



•5



•7

3.



•6



•7

4.



•5



•6

Une con una línea.

5.

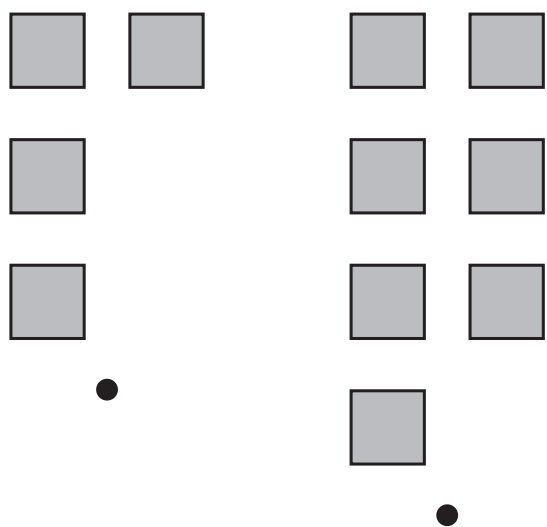

4

7

6.

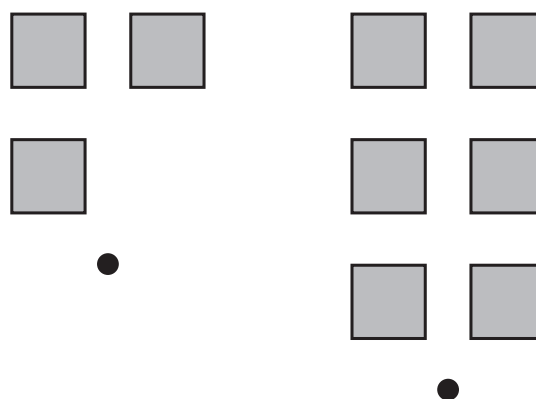

6

3

7.

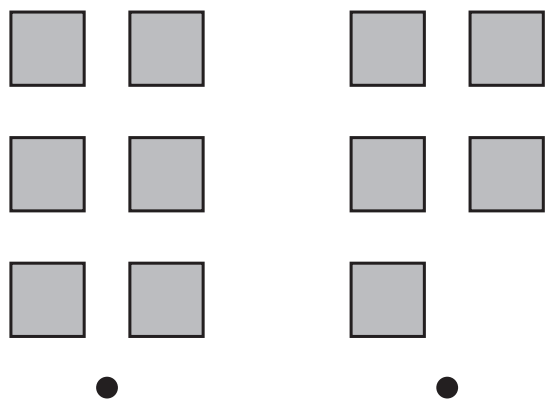

5

6

8.

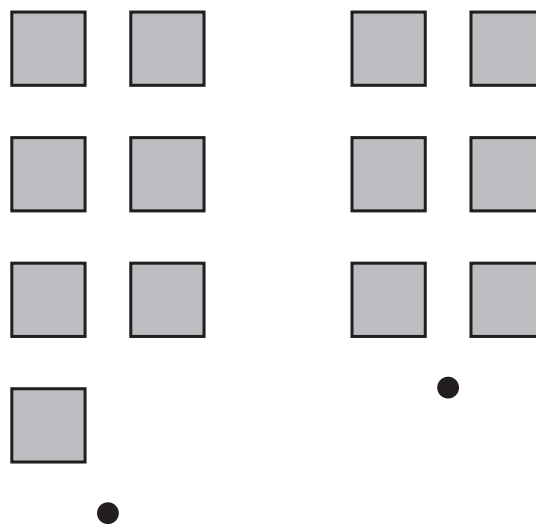

7

6

Une con una línea.

9.



•3

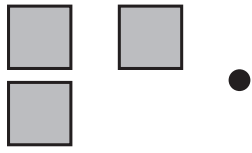

•7

10.

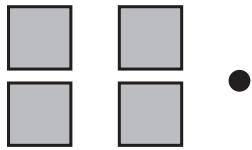

•4



•5

11.

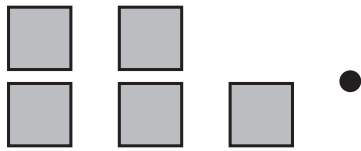

•6



•5

12.



•7

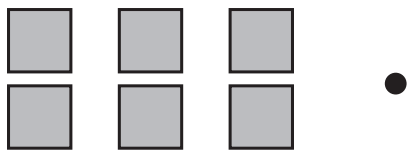

•6

CCInf-28 Escribir el 6 y el 7

Repasa.

1.

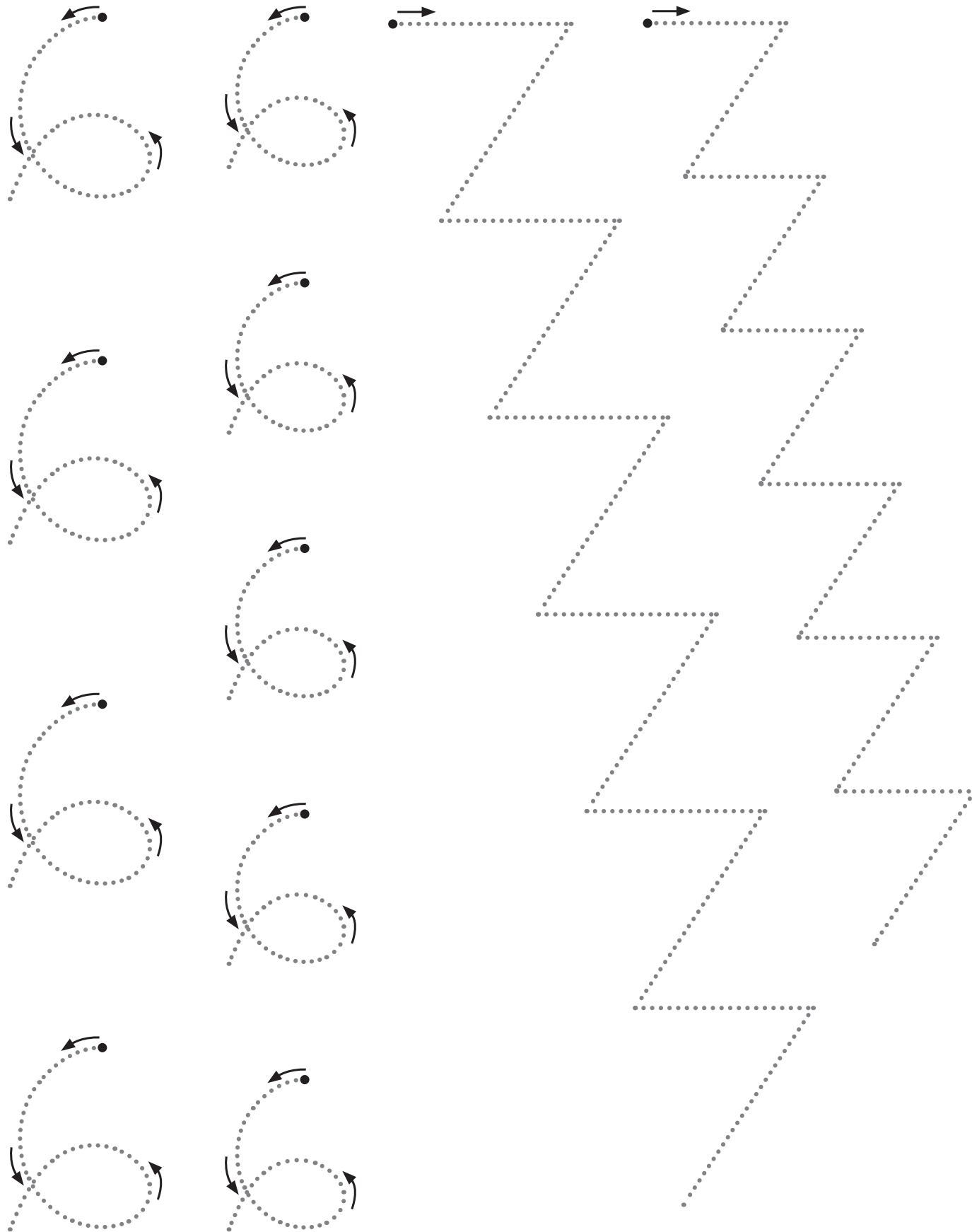

COPYRIGHT © 2017 JUMP MATH: PROHIBIDA LA REPRODUCCIÓN. EDICIÓN EN ESPAÑOL

Repasa.

2.

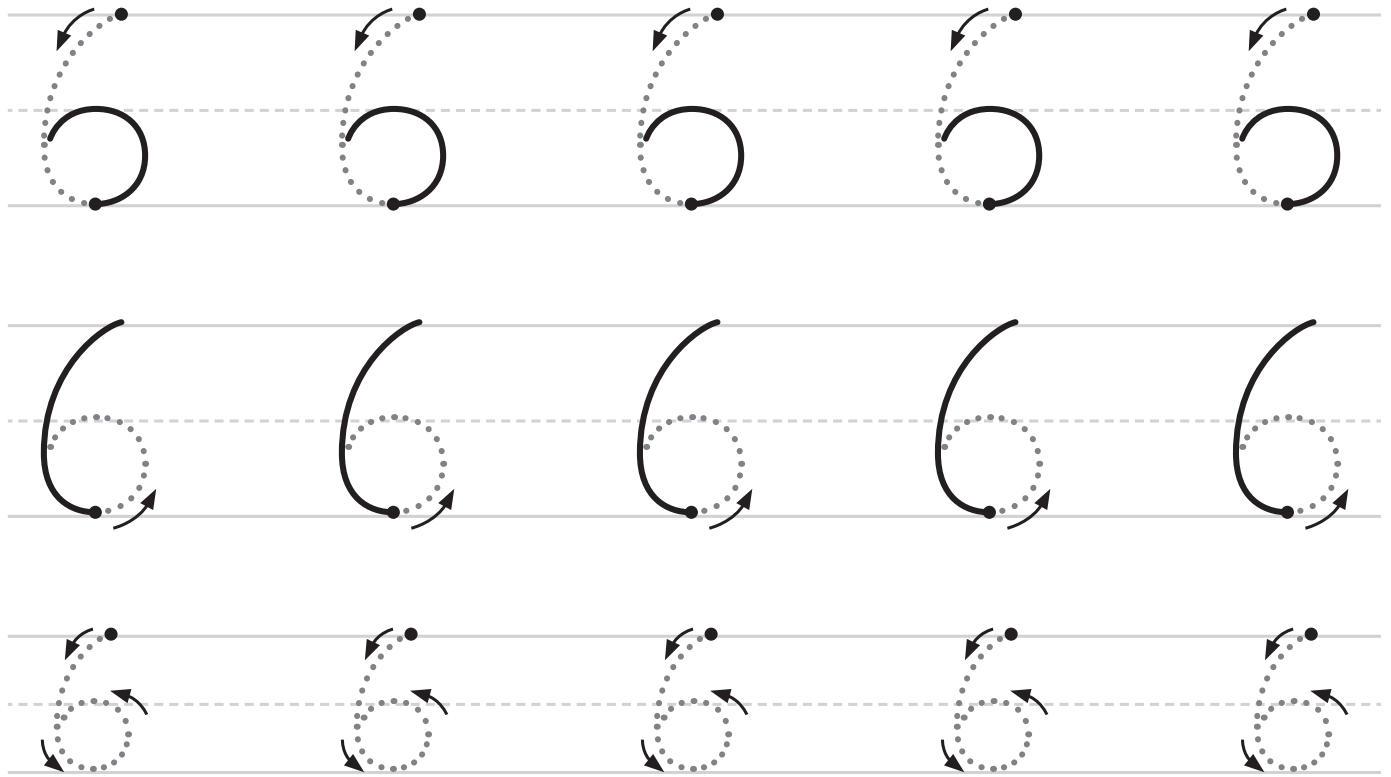

3.

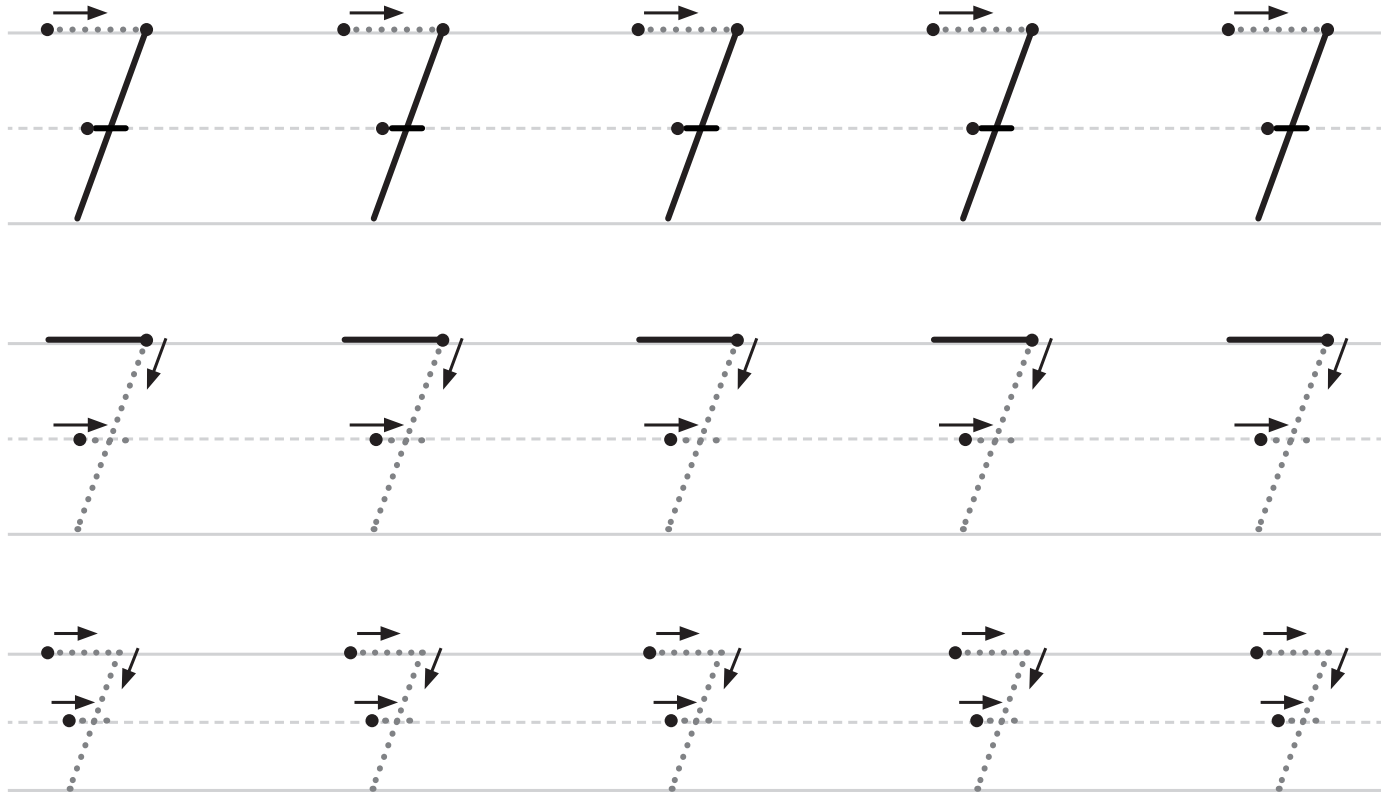

CCInf-29 Contar 8 y 9

Cuenta y tacha.

1.

4

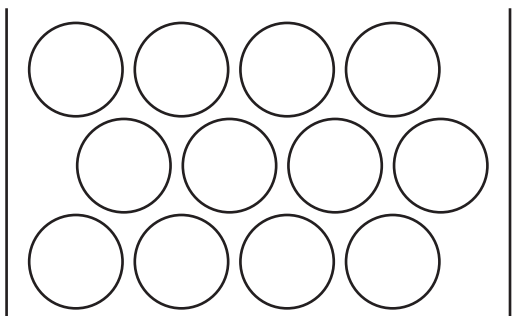

2.

6

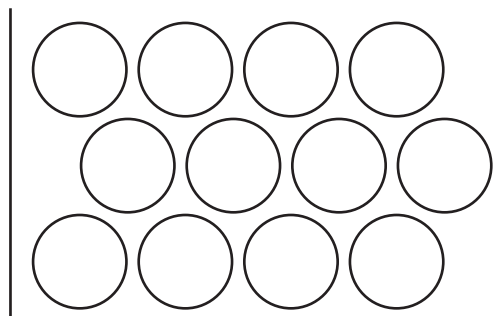

3.

9

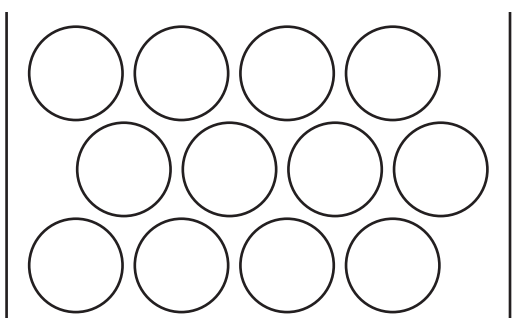

4.

8

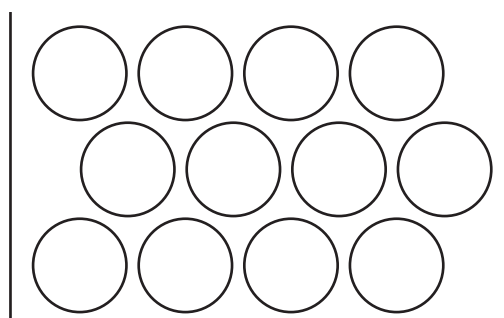

5.

7

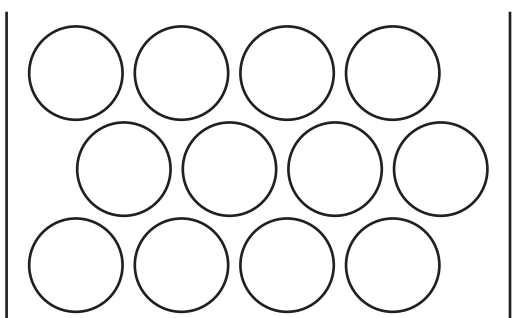

6.

5

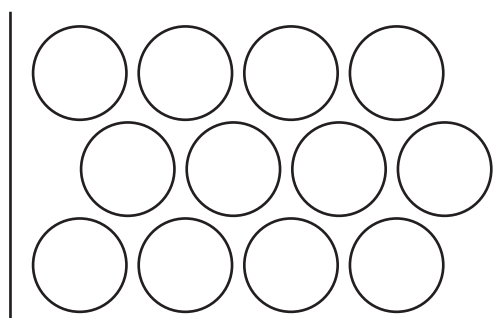

COPYRIGHT © 2017 JUMP MATH: PROHIBIDA LA REPRODUCCIÓN. EDICIÓN EN ESPAÑOL

- Usa ■.
- Mueve y cuenta cada ■.
- Rodea el número.

7.

8 9

8.

8 9

Usa ■.

Mueve y cuenta cada ■.

Rodea el número.

9.

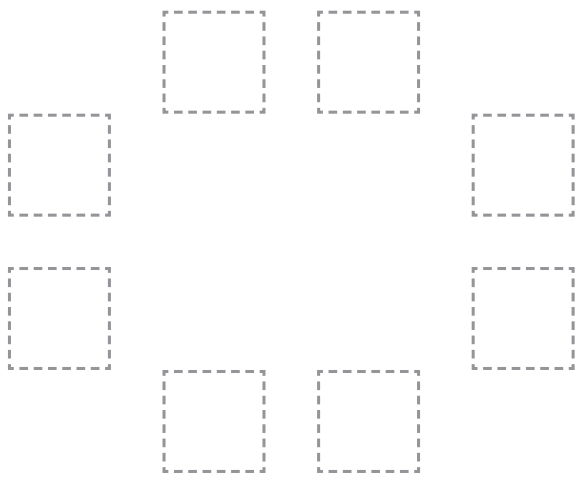

8

9

10.

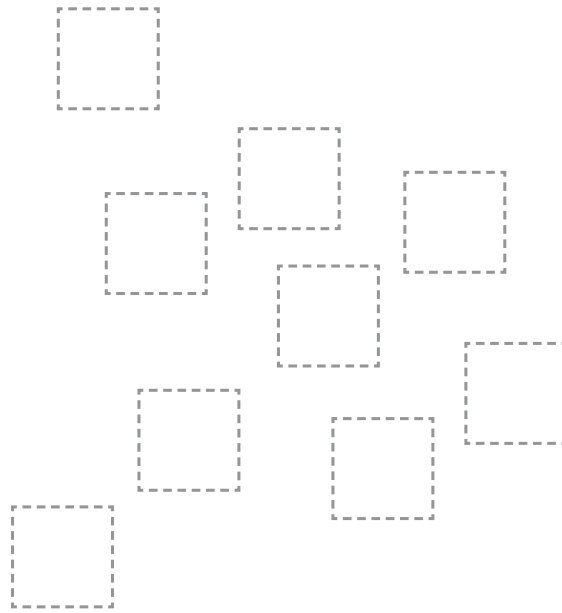

8

9

CCInf-30 Los números 8 y 9

Une con una línea.

1.

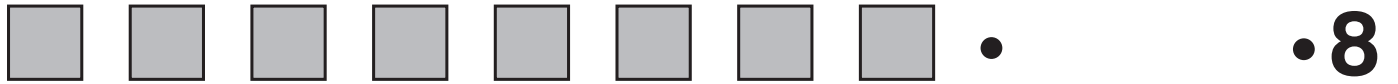

2.



3.



4.



Une con una línea.

5.

4 8

6.

6 9

7.

8 7

8.

9 8

EXTRA: Une con una línea.

9.

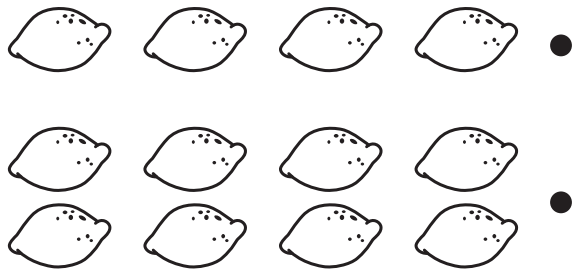

• 8

• 4

10.

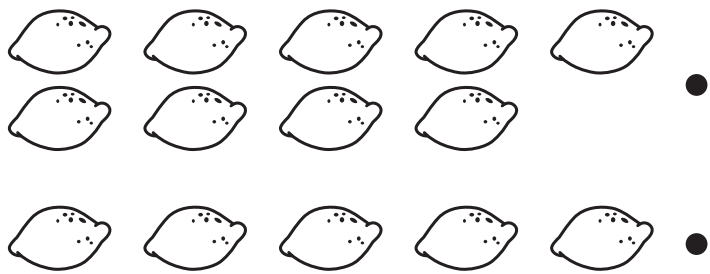

• 9

• 5

11.

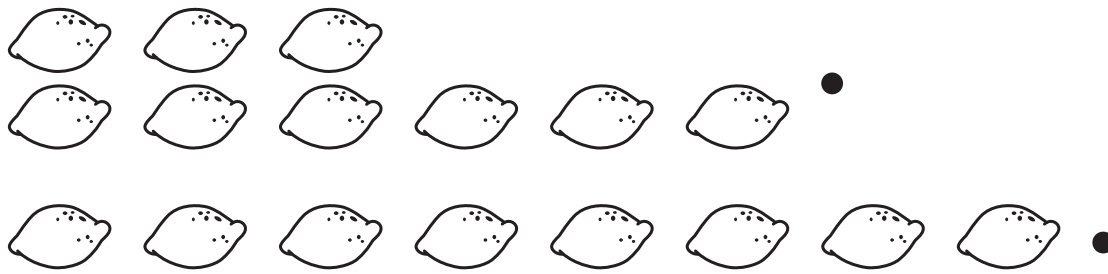

• 8

• 9

12.

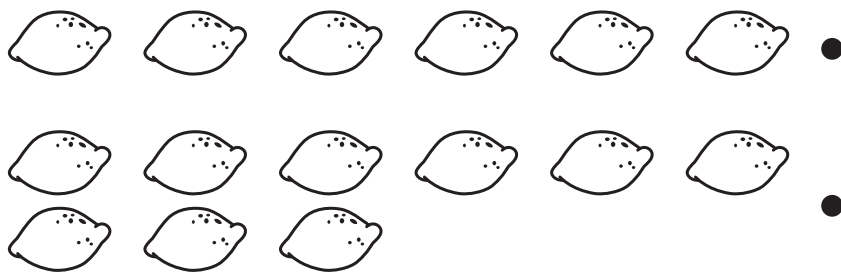

• 6

• 9

CCInf-31 Escribir el 8 y el 9

Repasa.

1.

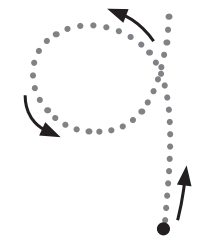
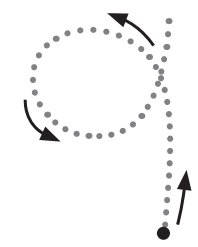
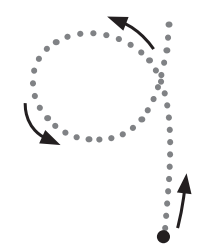
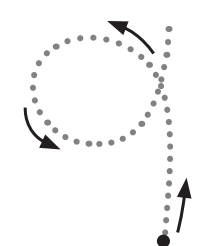
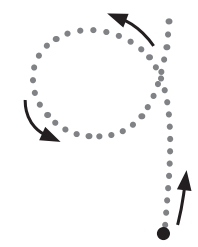
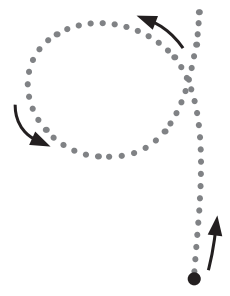
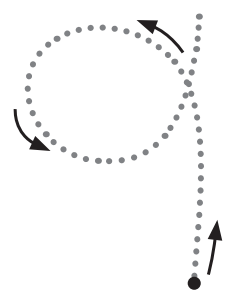
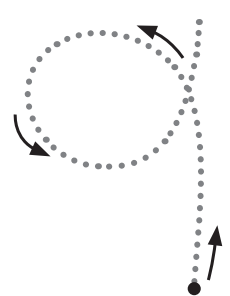
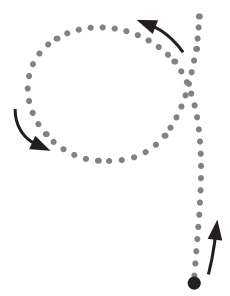
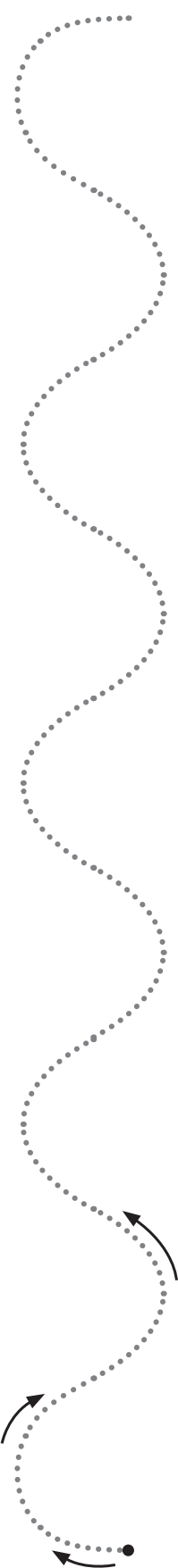
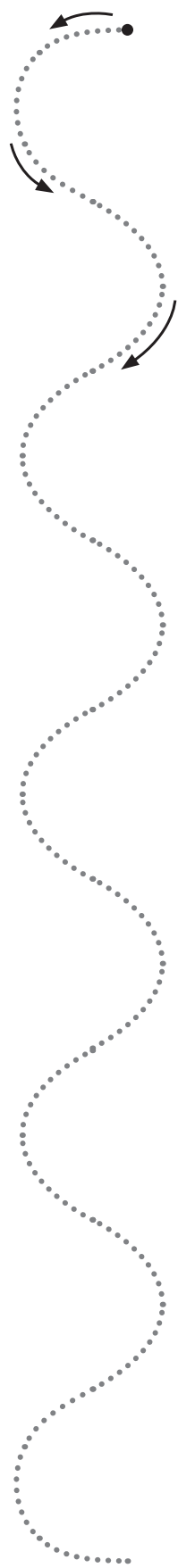

COPYRIGHT © 2017 JUMP MATH: PROHIBIDA LA REPRODUCCIÓN. EDICIÓN EN ESPAÑOL

Repasa.

2.

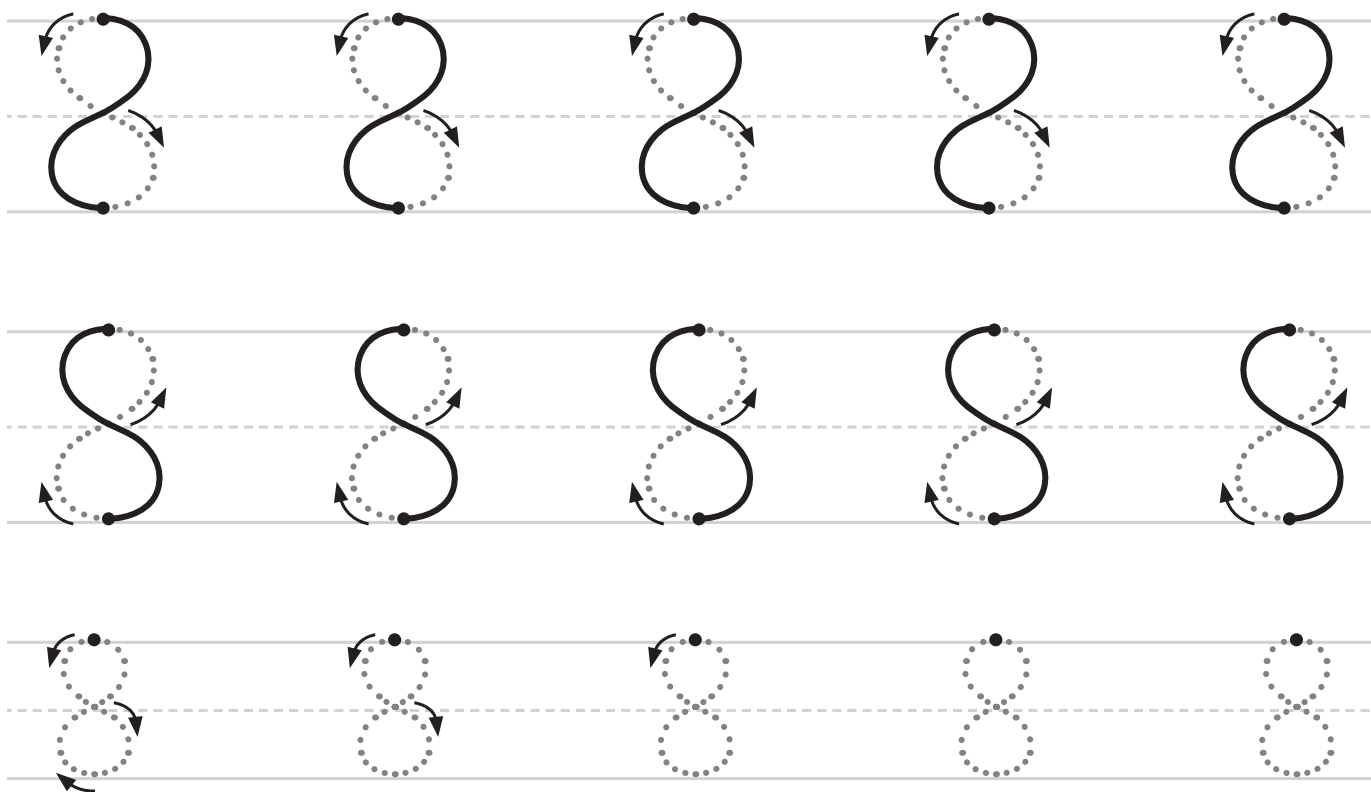

3.

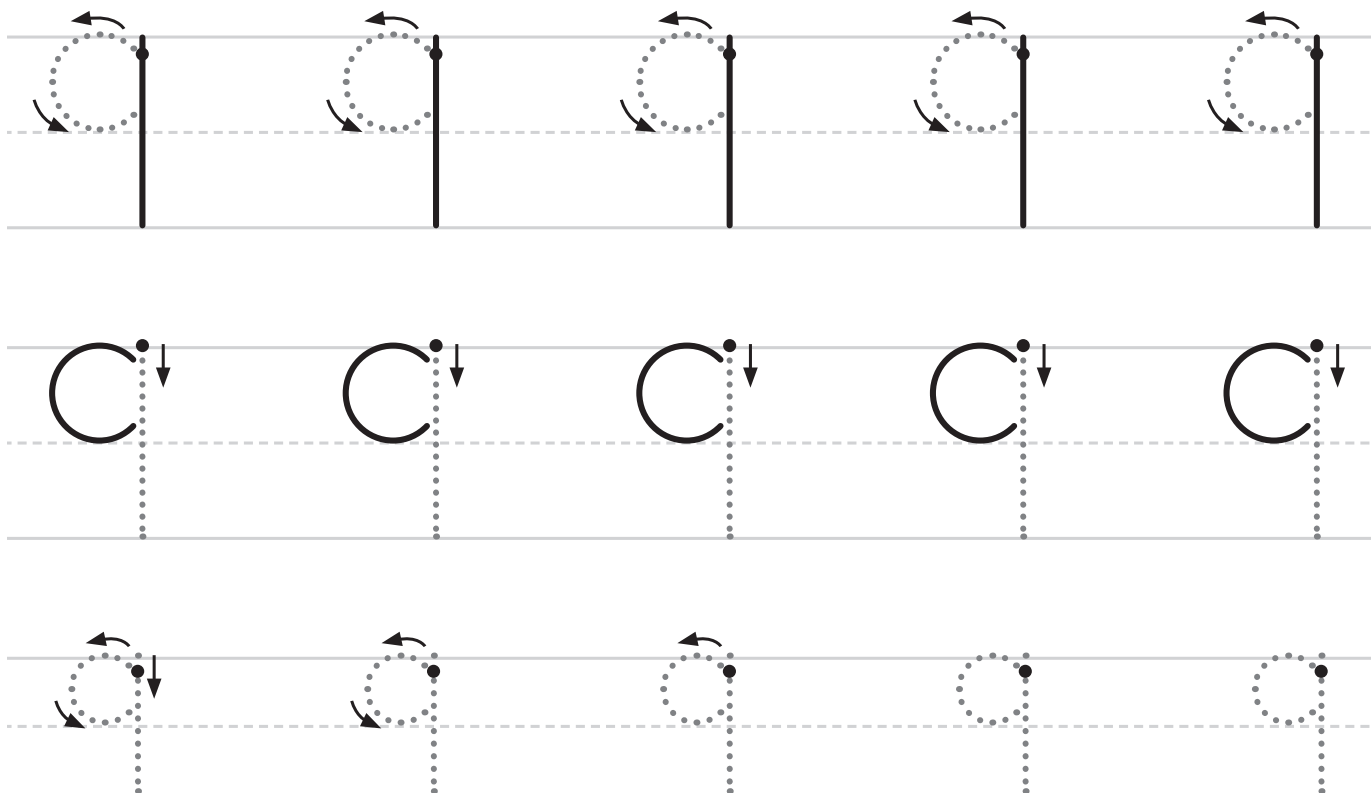

CCInf-32 Contar 10

¿Cuántos?

Cuenta. Rodea el número.

1.



1 2 3 4 5 6 7 8 9 10

2.

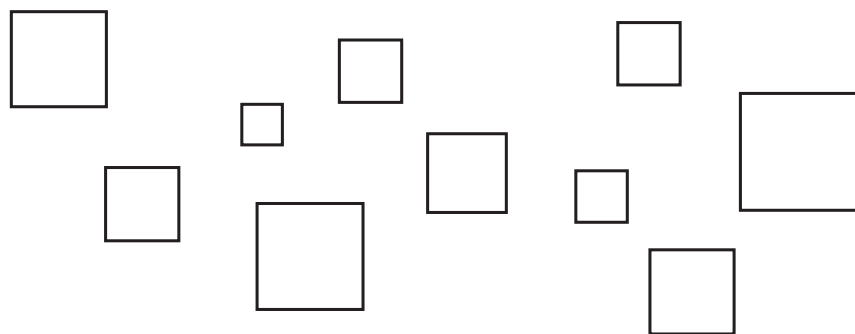

1 2 3 4 5 6 7 8 9 10

3.

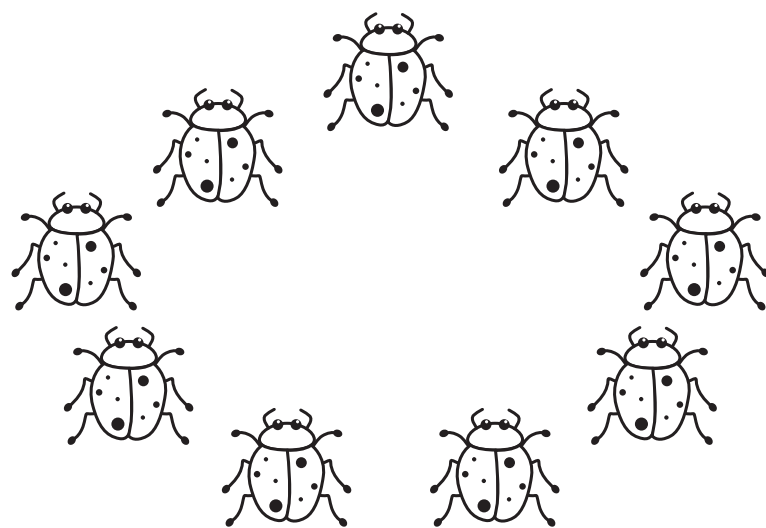

1 2 3 4 5 6 7 8 9 10

¿Cuántos?

Cuenta. Rodea el número.

4.



5.

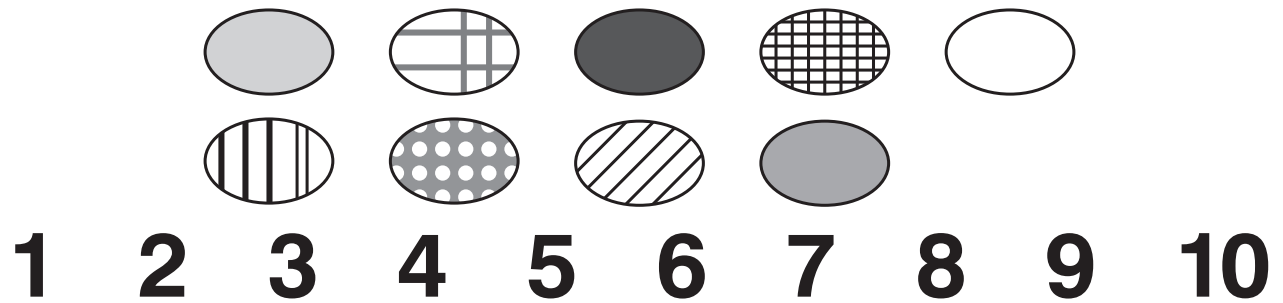

6.

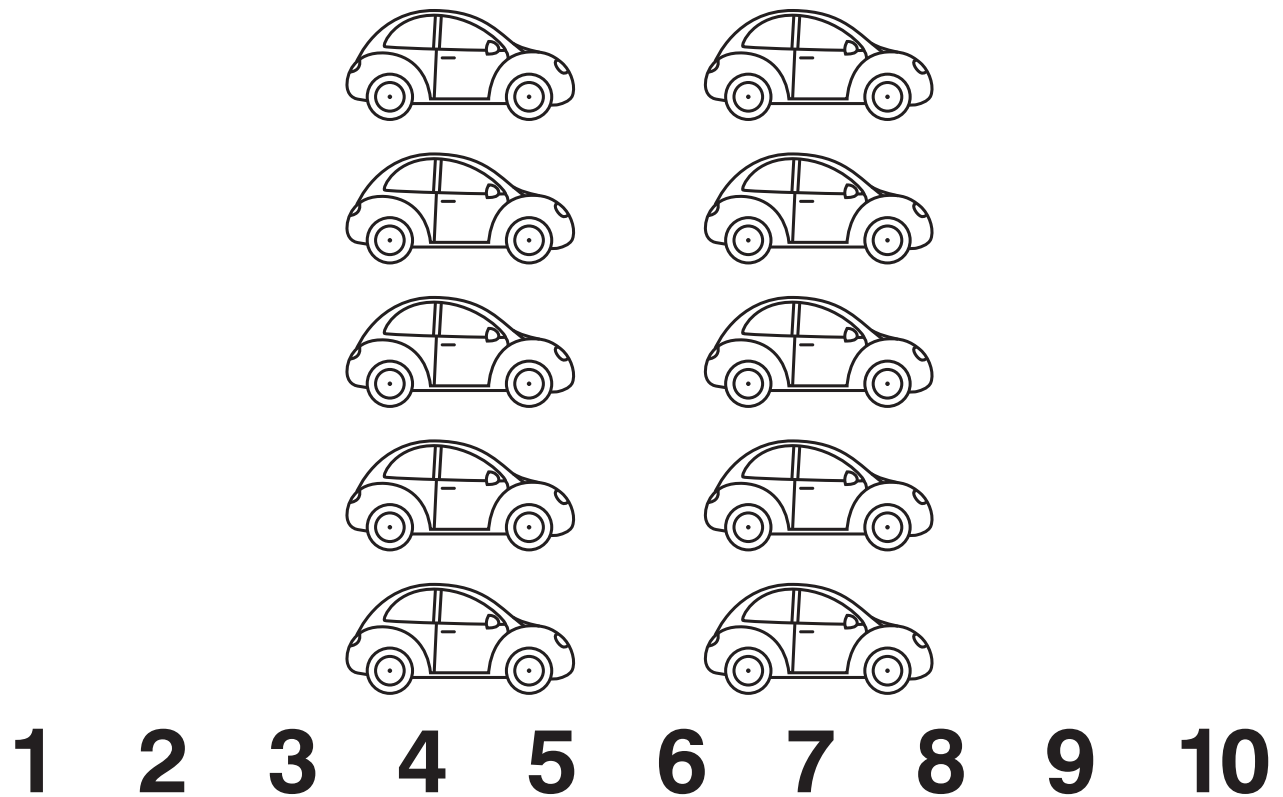

Cuenta y tacha.

7.

5

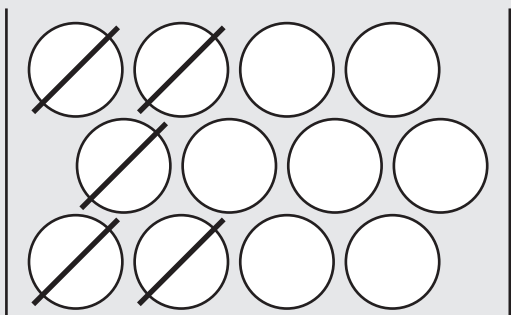

8.

8

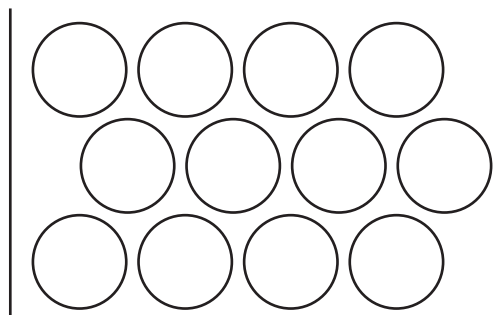

9.

7

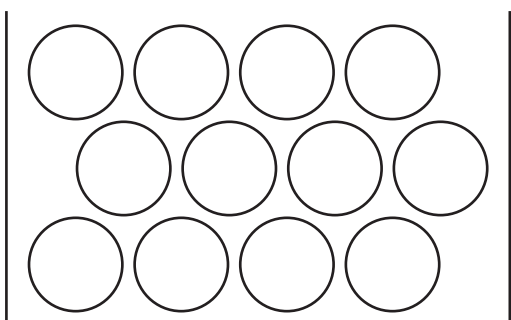

10.

9

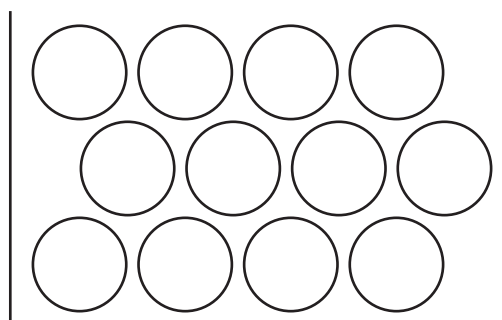

11.

10

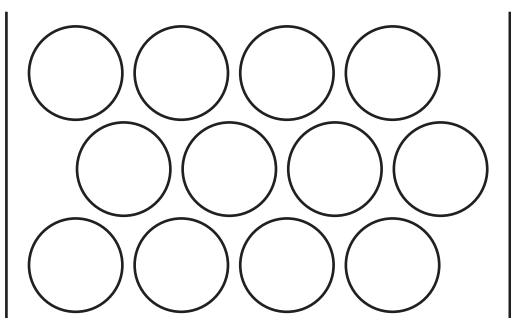

12.

6

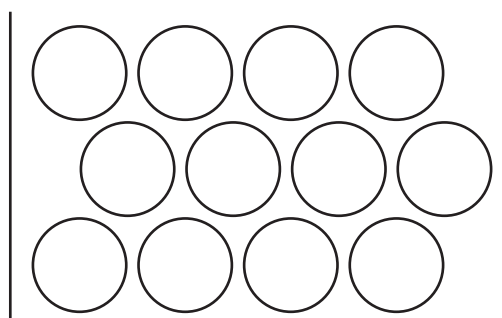

CCInf-33 El número 10

Une con una línea.

1.

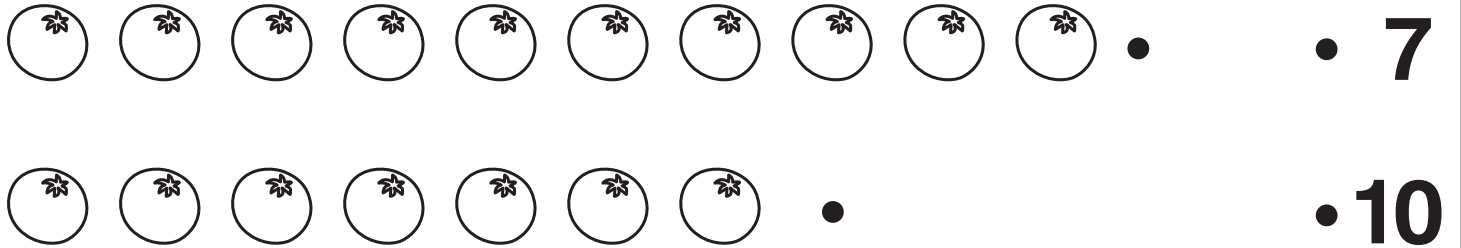

2.

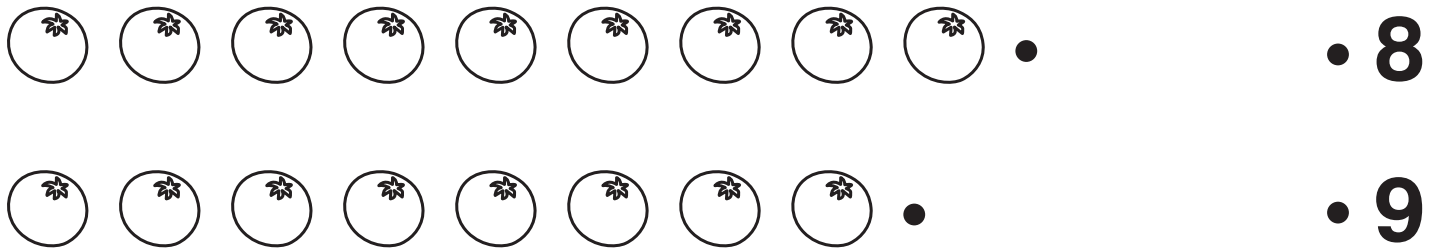

3.

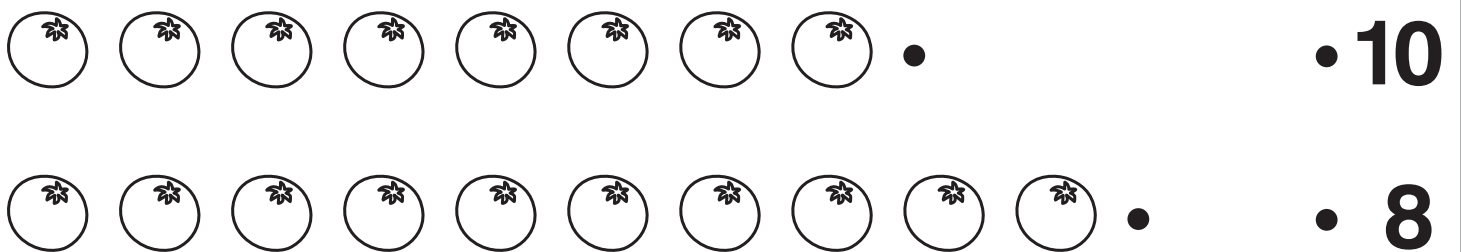

4.

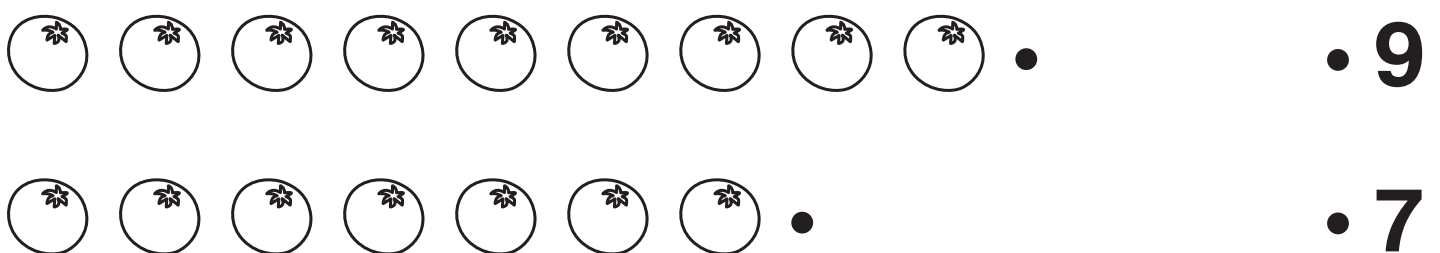

Une con una línea.

5.

8 10

6.

9 7

7.

9 8

8.

7 10

CCInf-34 Escribir el 10

Repasa.

1.

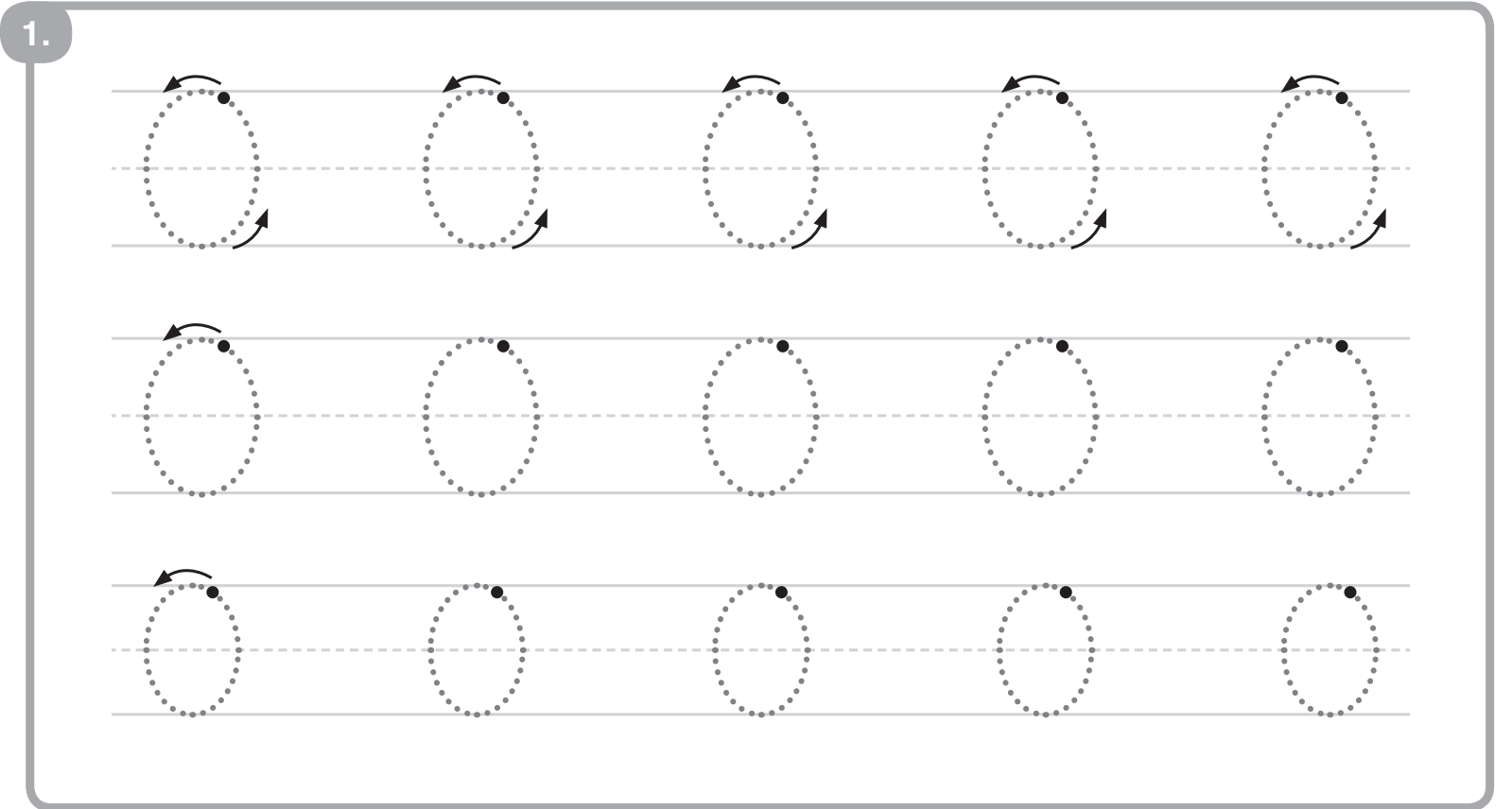

2.

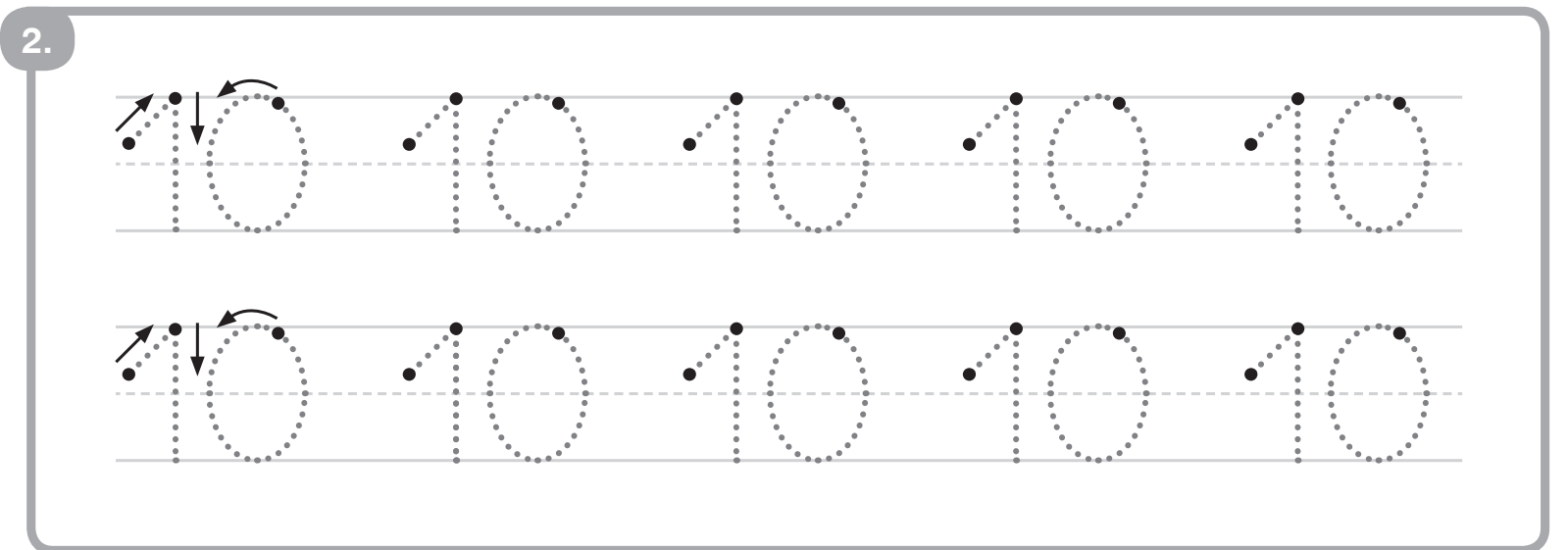

Escribe el 10.

3.



Repasa.

4.

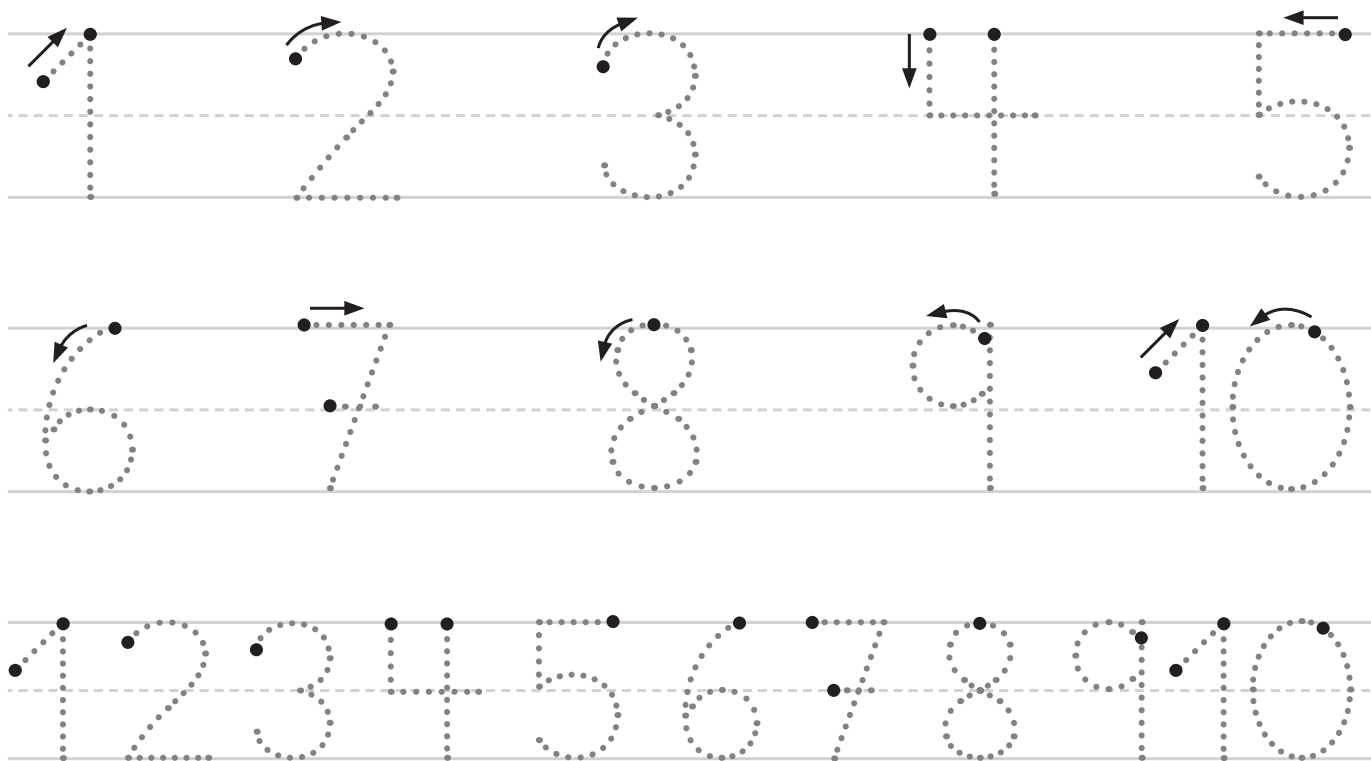

5.

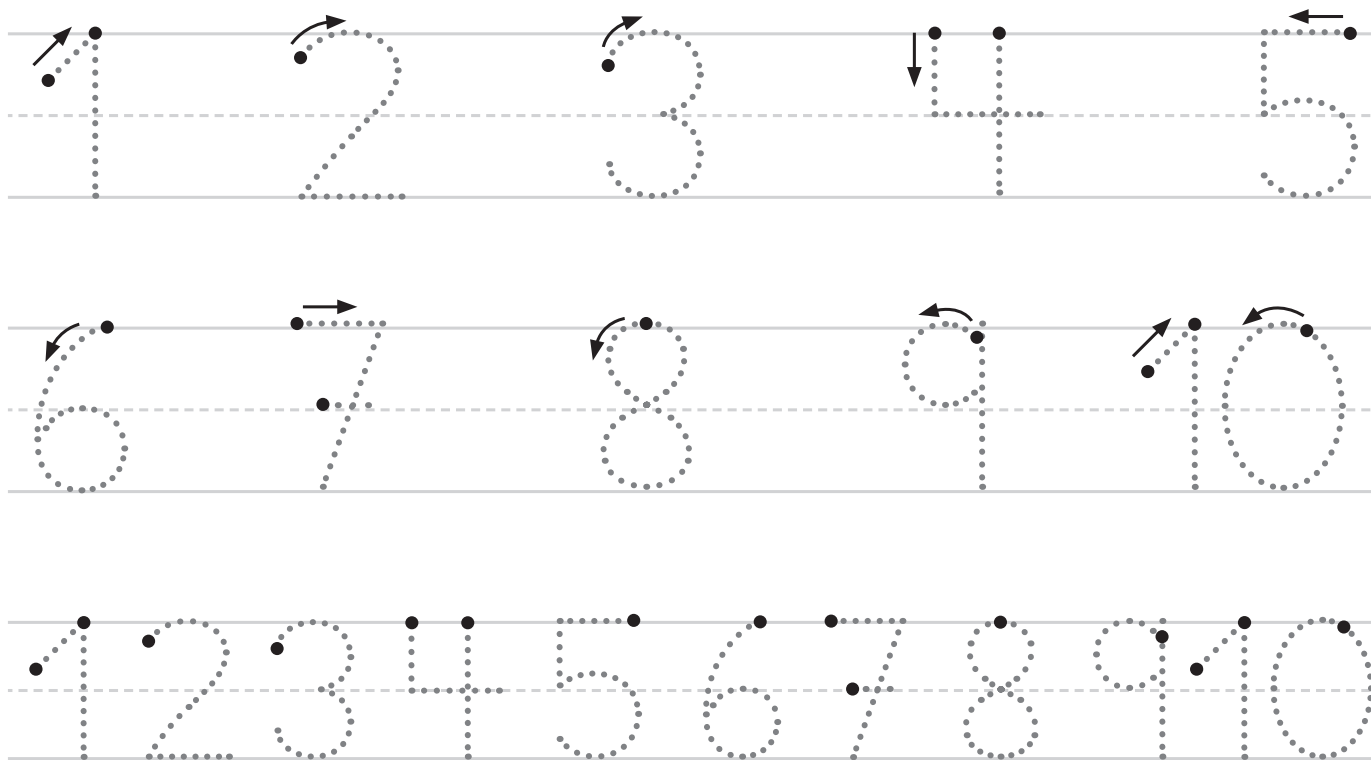

CCInf-35 Repaso de 0 a 10

Repasa.

Colorea el número de cuadrados.

1.

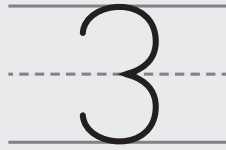

2.

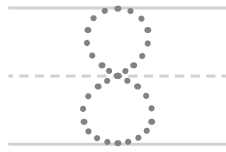

3.

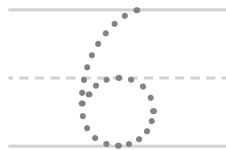

4.

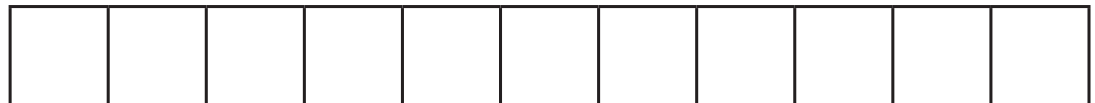
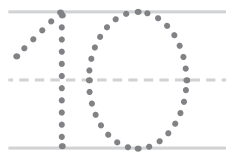



CCInf-36 Contar hasta el 50

Repasa.

1.

40

41

42

43

44

45

46

47

48

49

50

2.

4 4 4 4 4 4 4

COPYRIGHT © 2017 JUMP MATH: PROHIBIDA LA REPRODUCCIÓN. EDICIÓN EN ESPAÑOL

Escribe el 4.

3.

CCInf-37 Igual a

Une con una línea.

Colorea 😊 si es igual. Colorea ☹ si es diferente.

1.

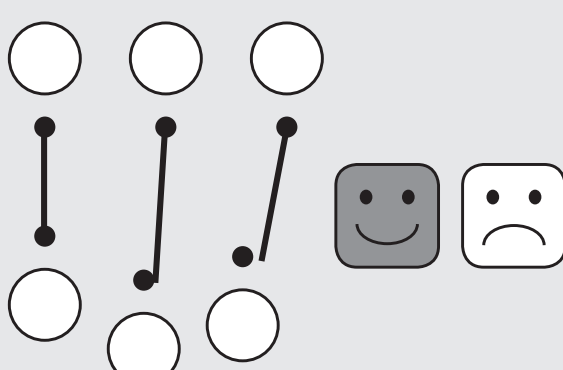

2.

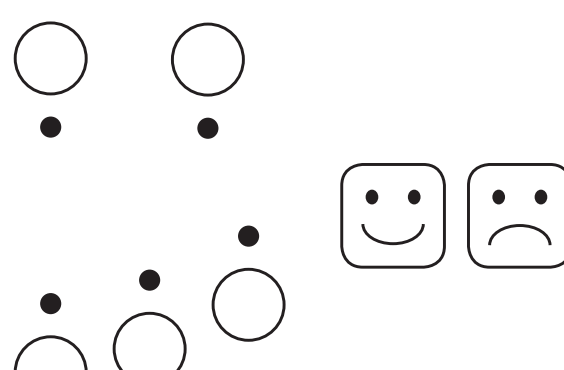

3.

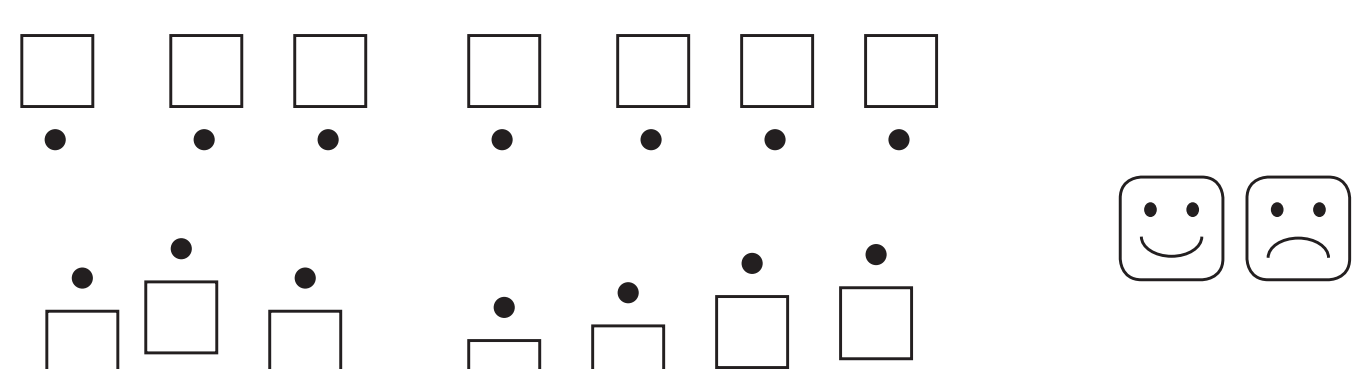

4.

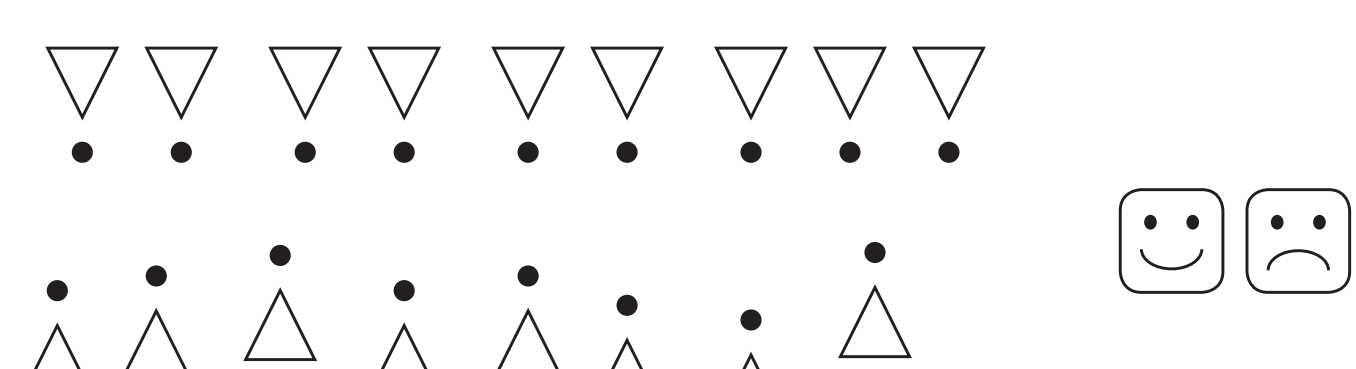

COPYRIGHT © 2017 JUMP MATH: PROHIBIDA LA REPRODUCCIÓN. EDICIÓN EN ESPAÑOL

Une con una línea.

Colorea 😊 si es igual. Colorea ☹️ si es diferente.

5.

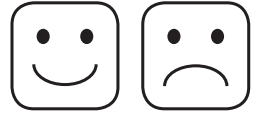
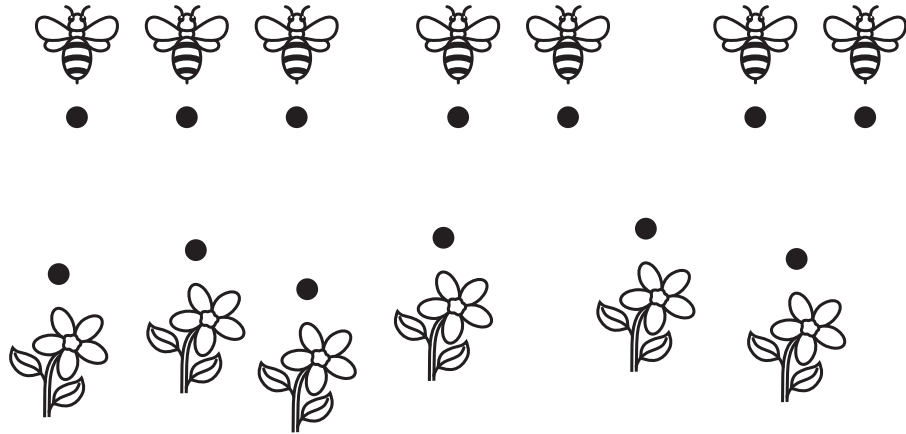

6.

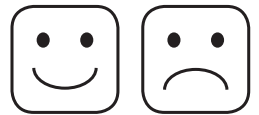
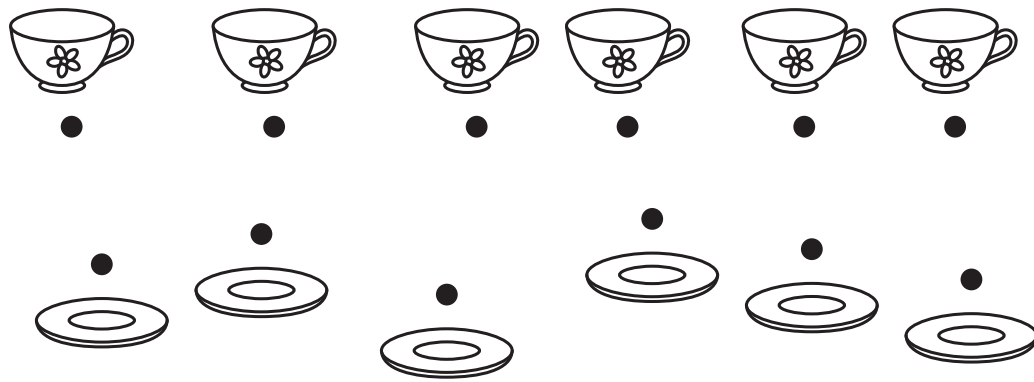

7.

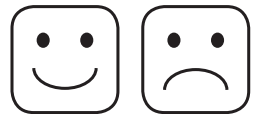
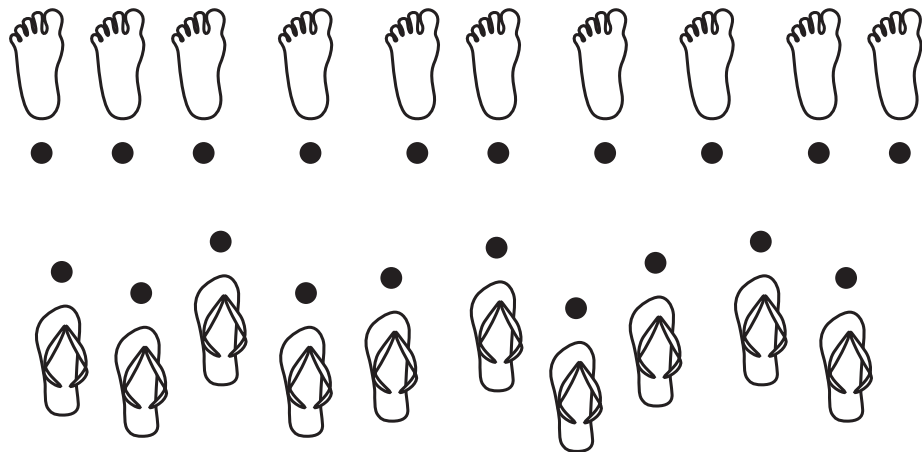

Cuenta. Rodea el número.

Colorea 😊 si es igual. Colorea ☹️ si es diferente.

8.

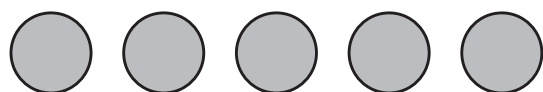

1 2 3 4 5 6 7 8 9 10



1 2 3 4 5 6 7 8 9 10

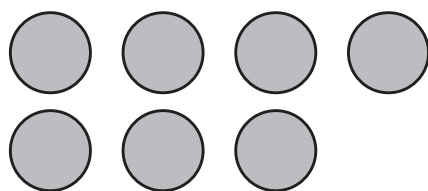

9.

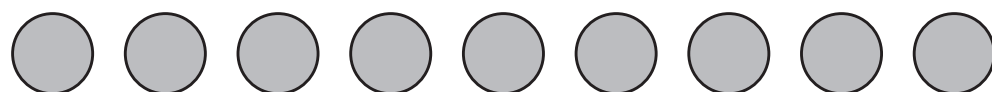

1 2 3 4 5 6 7 8 9 10



1 2 3 4 5 6 7 8 9 10

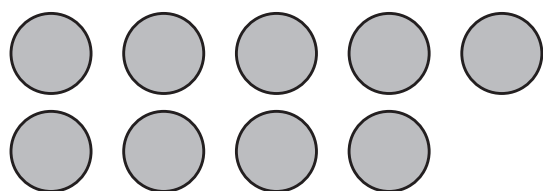

Cuenta. Rodea el número.

Colorea 😊 si es igual. Colorea ☹️ si es diferente.

10.

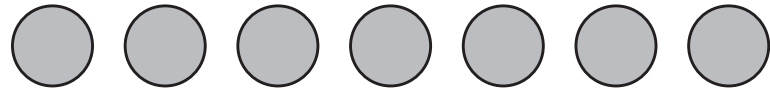

1 2 3 4 5 6 7 8 9 10



1 2 3 4 5 6 7 8 9 10

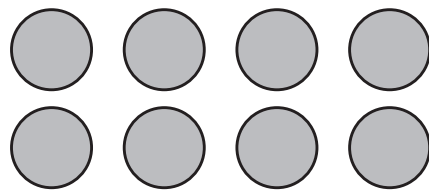

11.

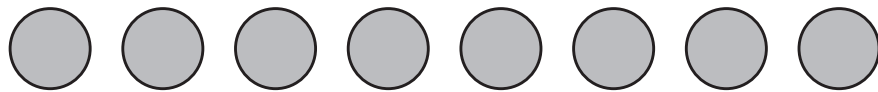

1 2 3 4 5 6 7 8 9 10



1 2 3 4 5 6 7 8 9 10

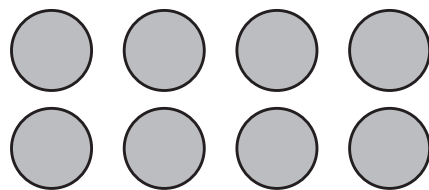

Cuenta. Rodea el número.

Colorea 😊 si es igual. Colorea ☹️ si es diferente.

12.

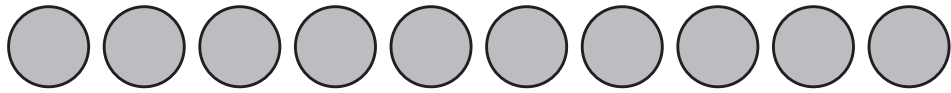

1 2 3 4 5 6 7 8 9 10



1 2 3 4 5 6 7 8 9 10

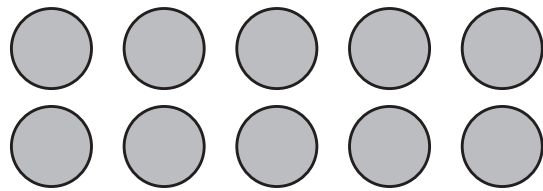

13.

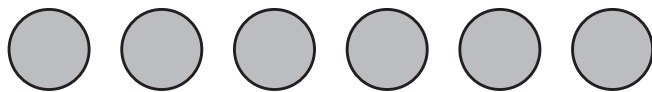

1 2 3 4 5 6 7 8 9 10



1 2 3 4 5 6 7 8 9 10

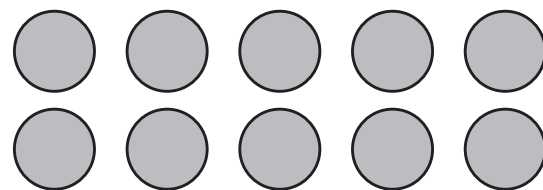

Cuenta. Rodea el número.

Colorea 😊 si es igual. Colorea ☹️ si es diferente.

14.

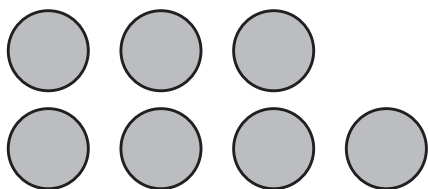

1 2 3 4 5 6 7 8 9 10



1 2 3 4 5 6 7 8 9 10

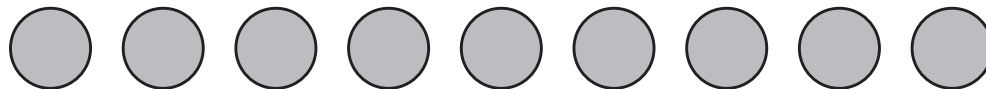

15. EXTRA

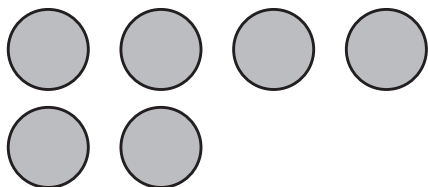

1 2 3 4 5 6 7 8 9 10



1 2 3 4 5 6 7 8 9 10

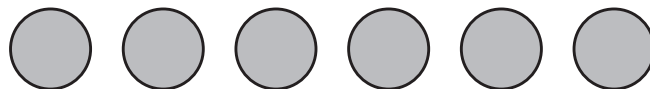

CCInf-38 Mayor que

Une con una línea.

Colorea el ☀ del grupo que tiene más elementos.

1.

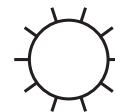
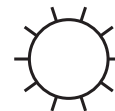
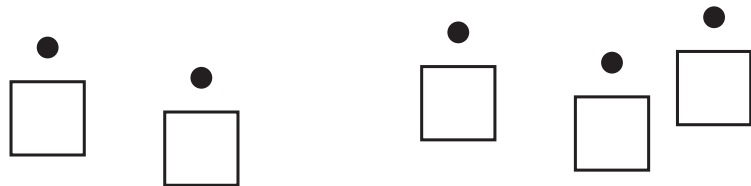

2.

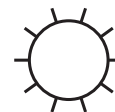
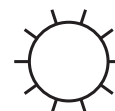
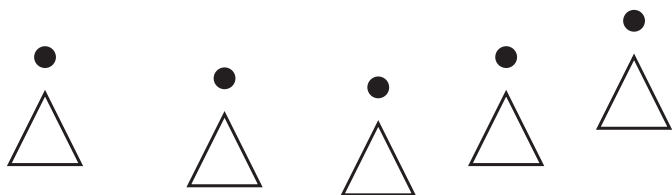

3.

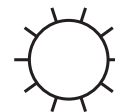
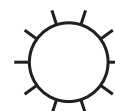
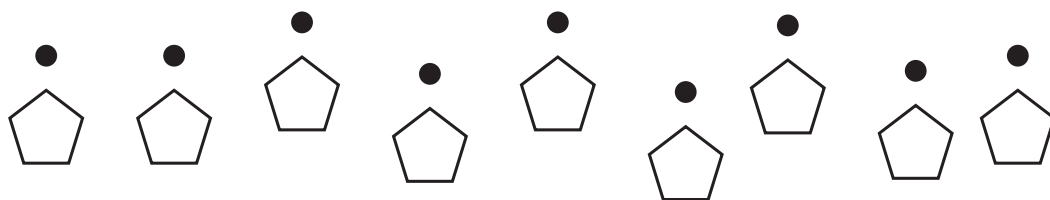
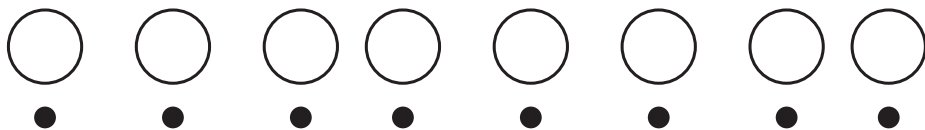

COPYRIGHT © 2017 JUMP MATH: PROHIBIDA LA REPRODUCCIÓN. EDICIÓN EN ESPAÑOL

Une con una línea.

Colorea el ☀ del grupo que tiene más elementos.

4.

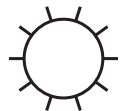
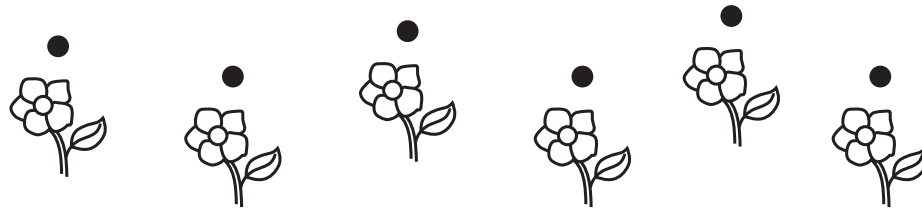
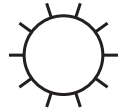
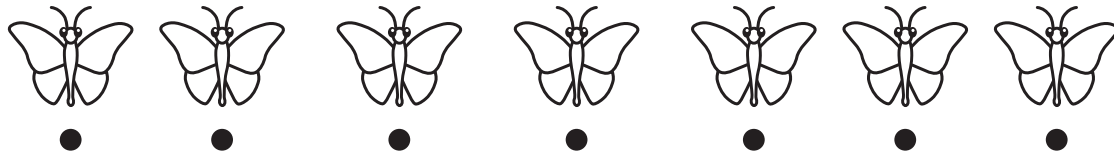

5.

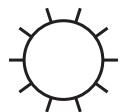
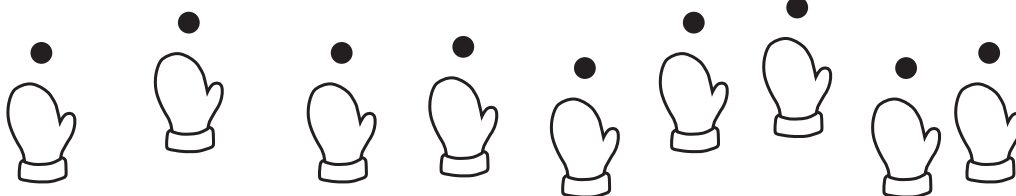
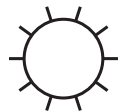
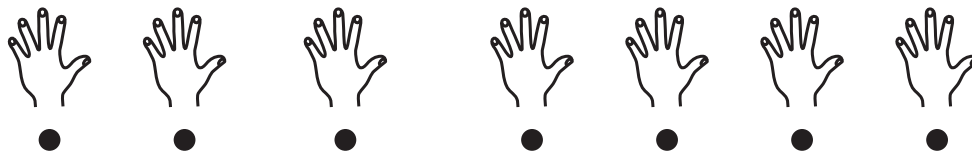

6.

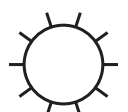
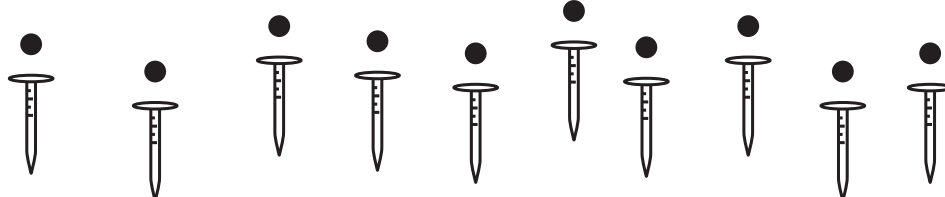
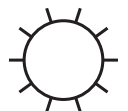
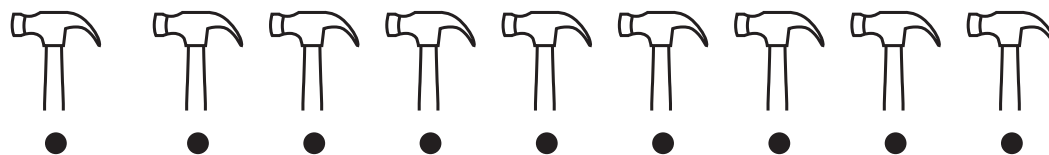

Cuenta. Rodea el número.

Colorea el ☀ del número mayor.

7.

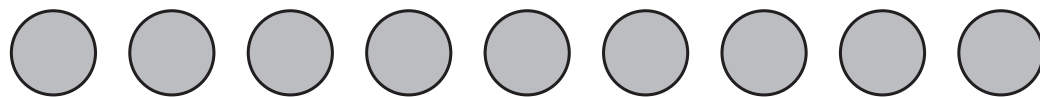

1 2 3 4 5 6 7 8 9 10

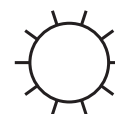

1 2 3 4 5 6 7 8 9 10

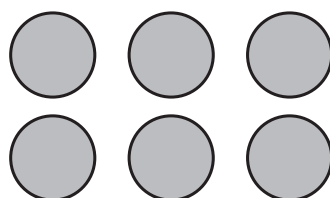
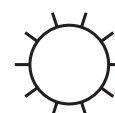

8.

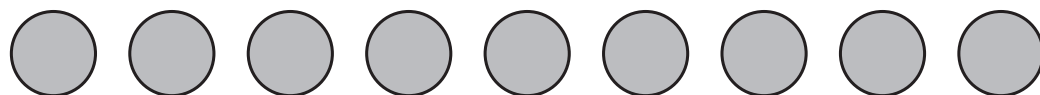

1 2 3 4 5 6 7 8 9 10

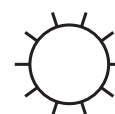

1 2 3 4 5 6 7 8 9 10

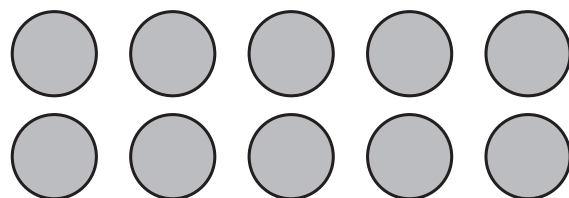
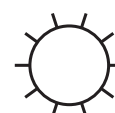

Cuenta. Rodea el número.

Colorea el ☀ del número mayor.

9.

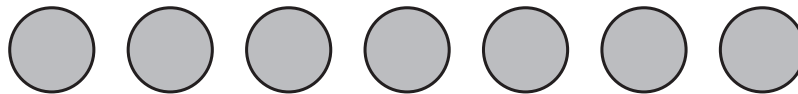

1 2 3 4 5 6 7 8 9 10

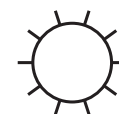

1 2 3 4 5 6 7 8 9 10

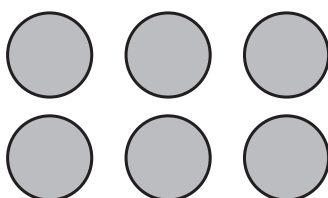
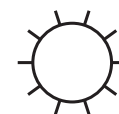

10.

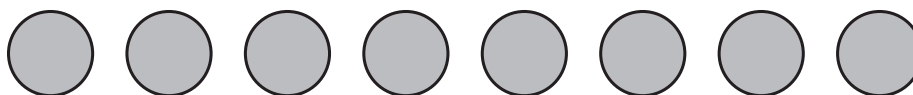

1 2 3 4 5 6 7 8 9 10

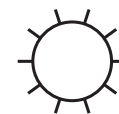

1 2 3 4 5 6 7 8 9 10

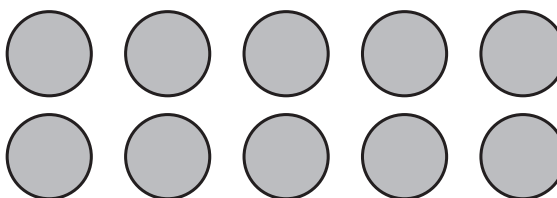
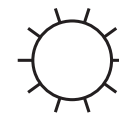

Cuenta. Rodea el número.

Colorea el ☀ del número mayor.

11.

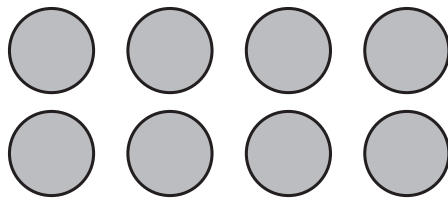

1 2 3 4 5 6 7 8 9 10

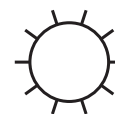

1 2 3 4 5 6 7 8 9 10

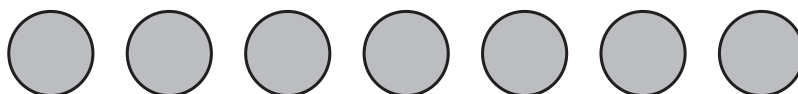
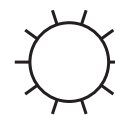

12.

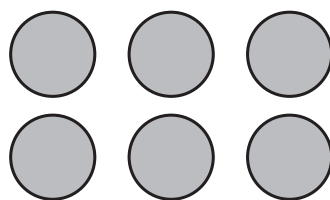

1 2 3 4 5 6 7 8 9 10

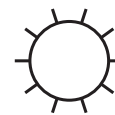

1 2 3 4 5 6 7 8 9 10

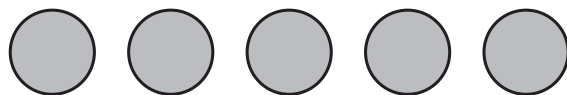
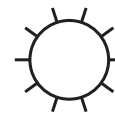

Cuenta. Rodea el número.

Colorea el ☀ del número mayor.

13. EXTRA

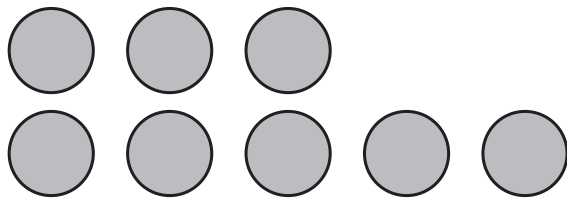

1 2 3 4 5 6 7 8 9 10

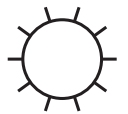

1 2 3 4 5 6 7 8 9 10

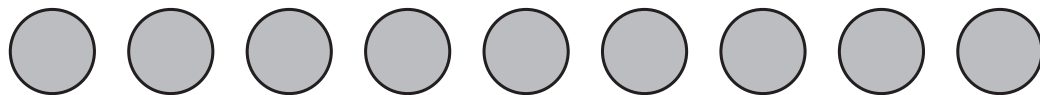
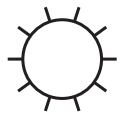

14. EXTRA

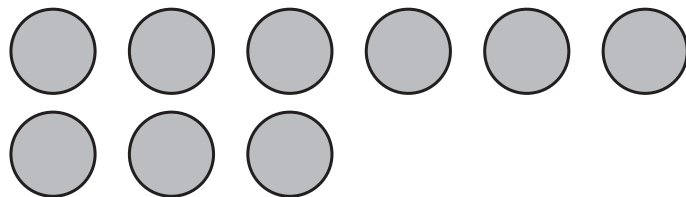

1 2 3 4 5 6 7 8 9 10

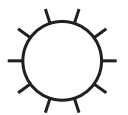

1 2 3 4 5 6 7 8 9 10

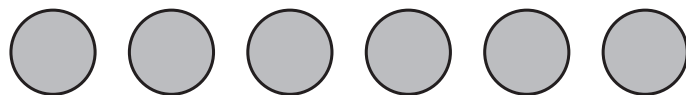
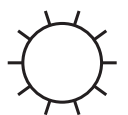

CCInf-39 *Menor que*

Une con una línea.

Colorea el ☀ del grupo que tiene menos elementos.

1.

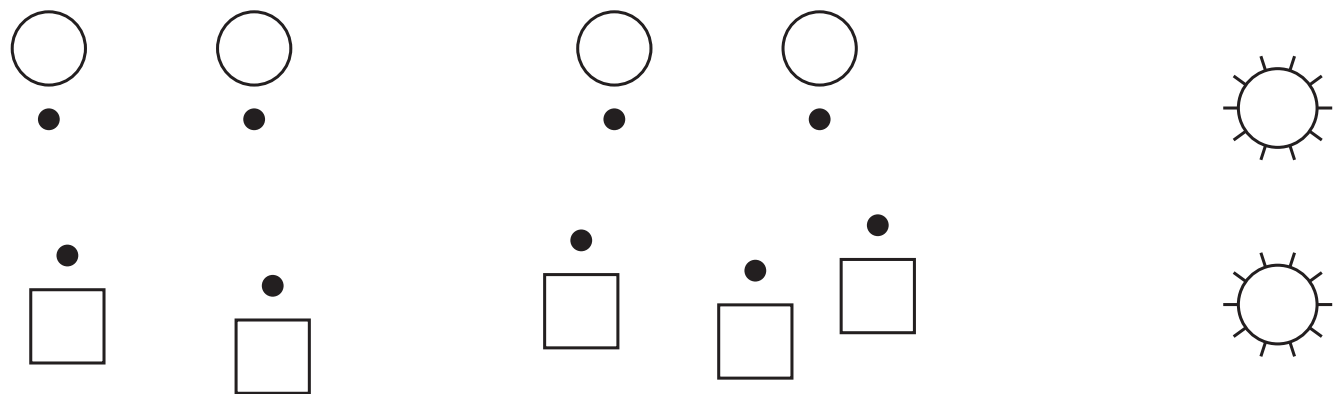

2.

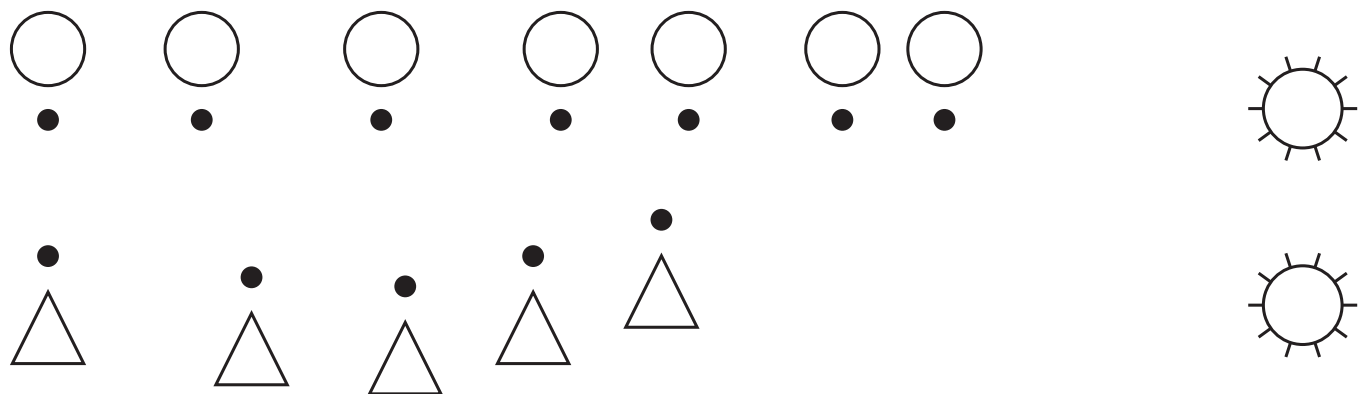

3.

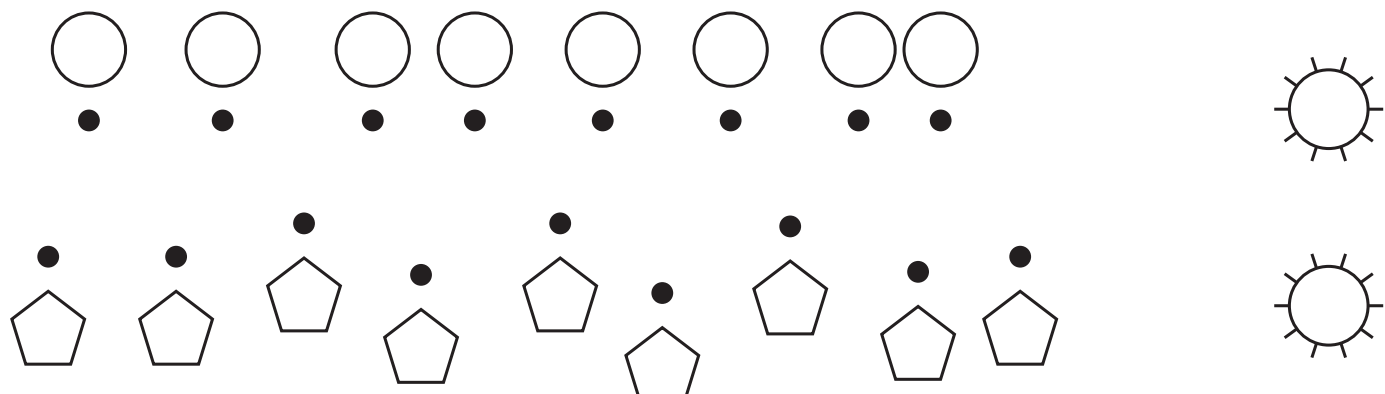

COPYRIGHT © 2017 JUMP MATH: PROHIBIDA LA REPRODUCCIÓN. EDICIÓN EN ESPAÑOL

Une con una línea.

Colorea el ☀ del grupo que tiene menos elementos.

4.

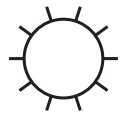
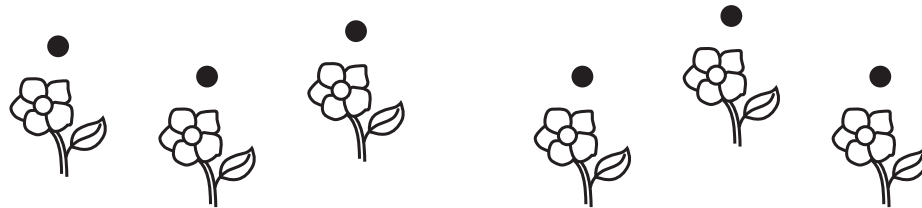
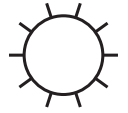
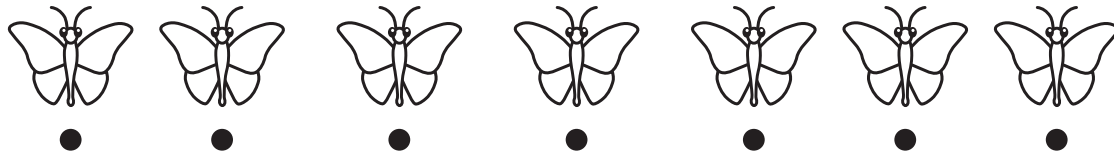

5.

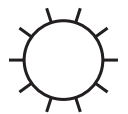
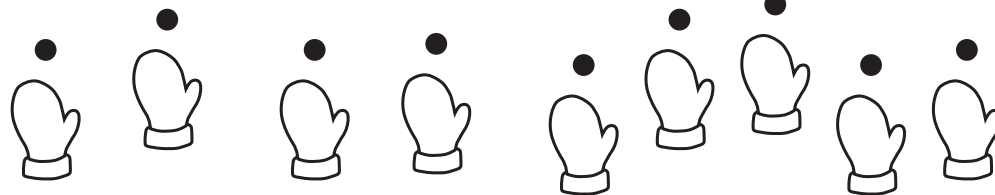
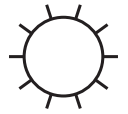

6.

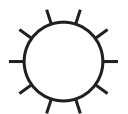
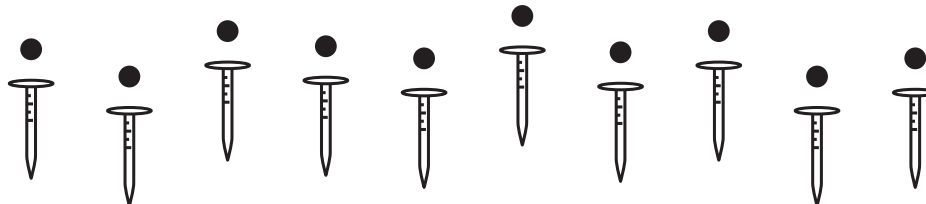
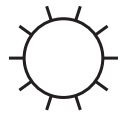
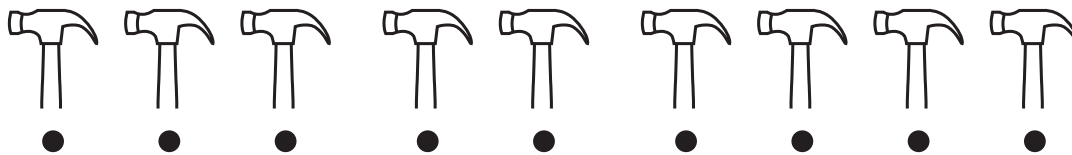

Cuenta. Rodea el número.

Colorea el ☀ del número menor.

7.

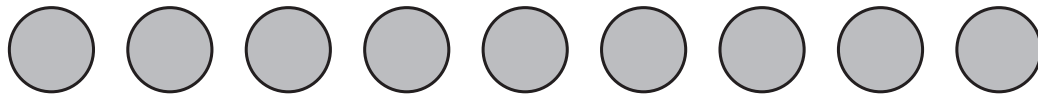

1 2 3 4 5 6 7 8 9 10

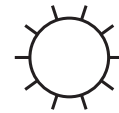

1 2 3 4 5 6 7 8 9 10

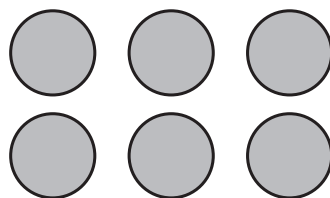
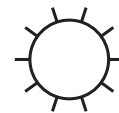

8.

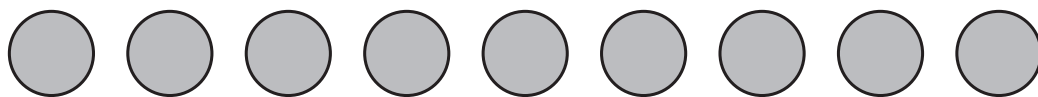

1 2 3 4 5 6 7 8 9 10

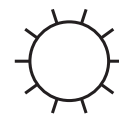

1 2 3 4 5 6 7 8 9 10

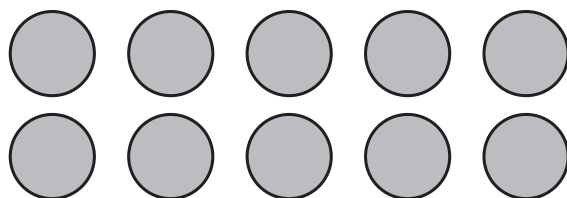
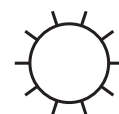

Cuenta. Rodea el número.

Colorea el ☀ del número menor.

9.

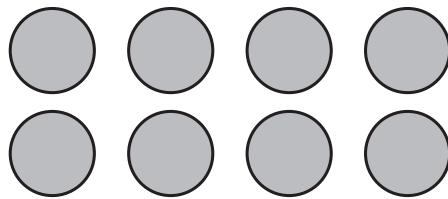

1 2 3 4 5 6 7 8 9 10

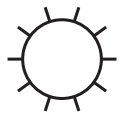

1 2 3 4 5 6 7 8 9 10

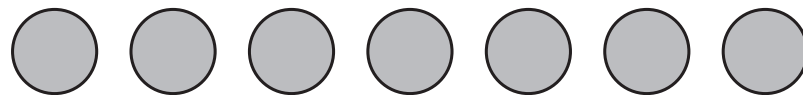
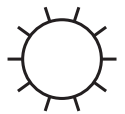

10.

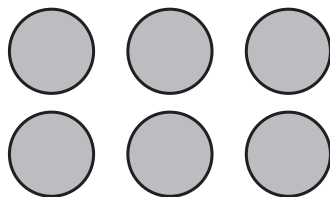

1 2 3 4 5 6 7 8 9 10

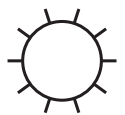

1 2 3 4 5 6 7 8 9 10

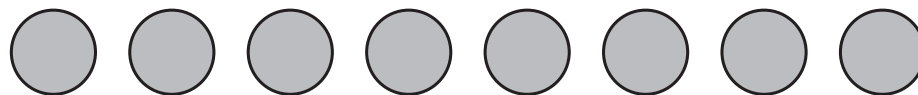
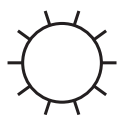

Cuenta. Rodea el número.

Colorea el ☀ del número menor.

11.

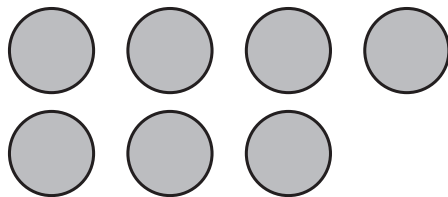

1 2 3 4 5 6 7 8 9 10

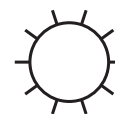

1 2 3 4 5 6 7 8 9 10

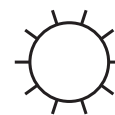

12.

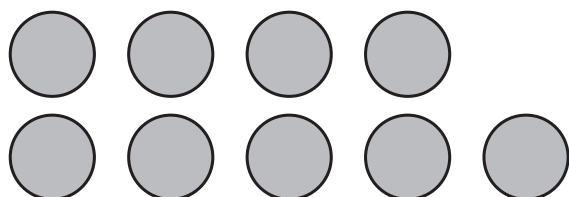

1 2 3 4 5 6 7 8 9 10

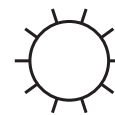

1 2 3 4 5 6 7 8 9 10

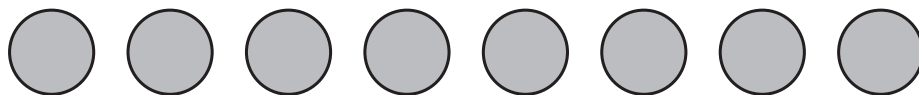
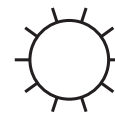

Cuenta. Rodea el número.

Colorea el ☀ del número menor.

13. EXTRA

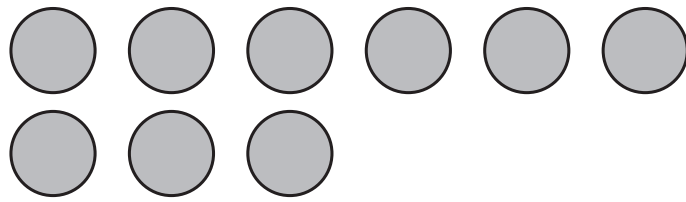

1 2 3 4 5 6 7 8 9 10

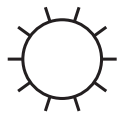

1 2 3 4 5 6 7 8 9 10

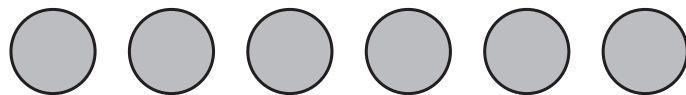
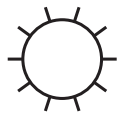

14. EXTRA

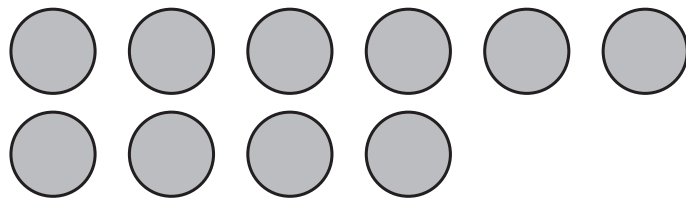

1 2 3 4 5 6 7 8 9 10

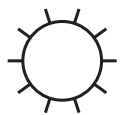

1 2 3 4 5 6 7 8 9 10

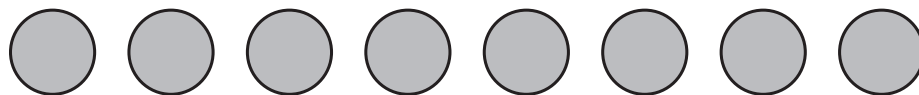
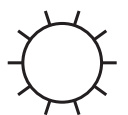

CCInf-40 *Uno más que*

Dibuja una línea debajo del número.

Rodea el número siguiente.

1.

4 1 2 3 4 (5) 6 7 8 9 10

2.

9 1 2 3 4 5 6 7 8 9 10

3.

5 1 2 3 4 5 6 7 8 9 10

4.

2 1 2 3 4 5 6 7 8 9 10

5.

8 1 2 3 4 5 6 7 8 9 10

- Une con una línea.
- Rodea los ● que sobran.
- Escribe cuántos sobran.

6.

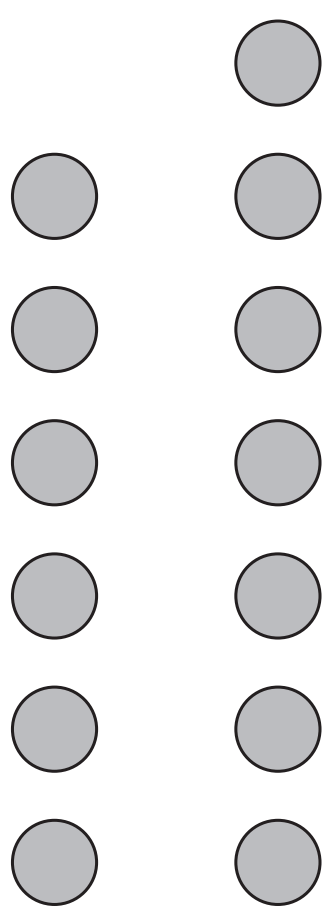

6 **7**

7.

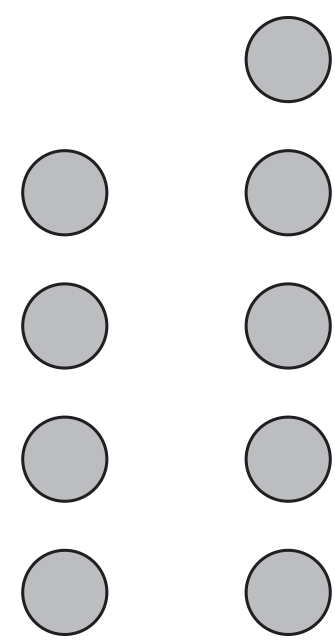

4 **5**

8.

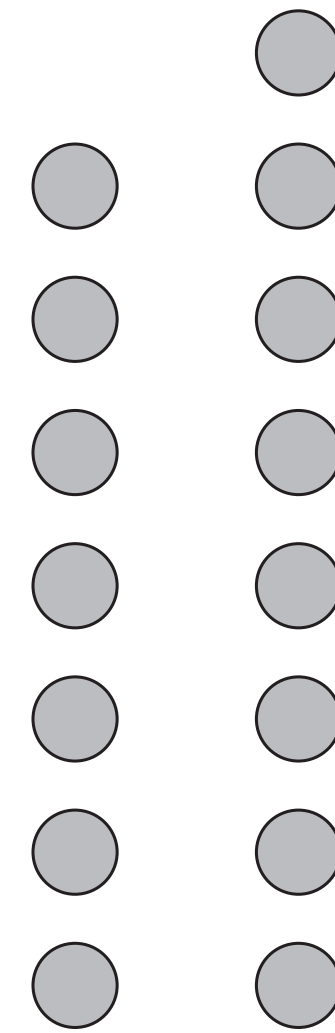

7 **8**

Escribe el número siguiente.

Colorea para obtener el número siguiente.

9.

4

10.

5

11.

9

Escribe el número siguiente.

Colorea para obtener el número siguiente.

12.

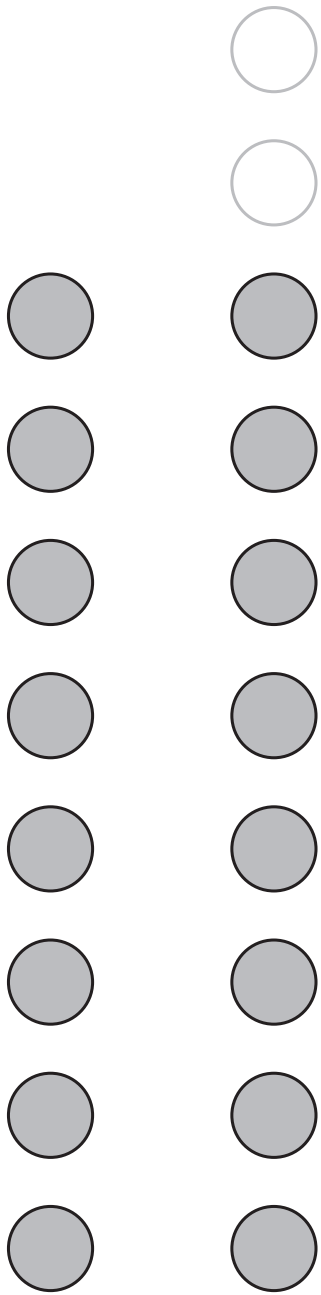

8

13.

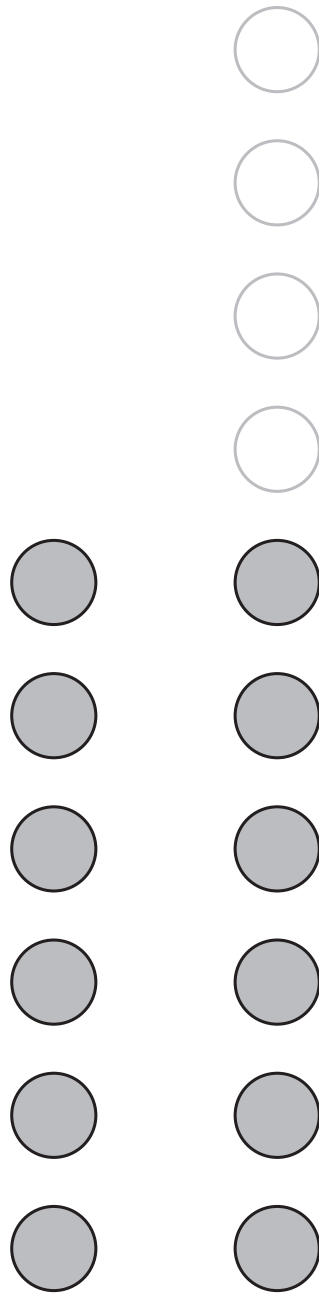

6

14.

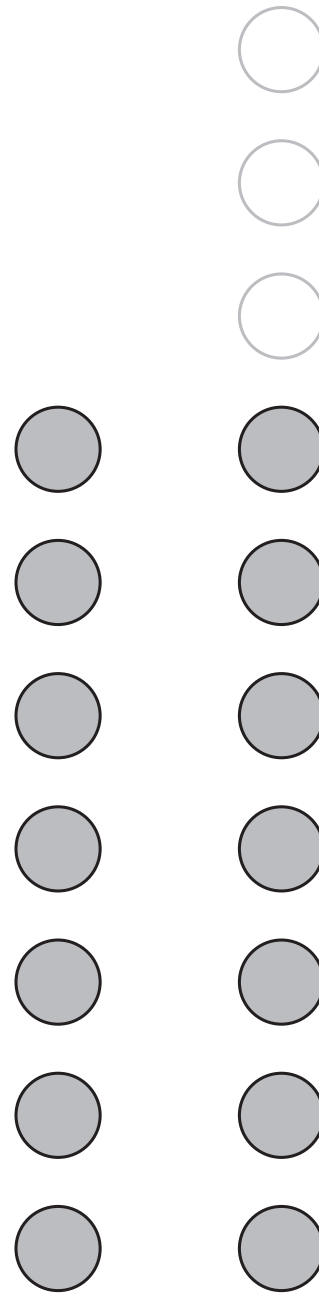

7

CCInf-41 Comparar números

Rodea los números.

Colorea el ☀ del número mayor.

1.

7 ☀

1 2 3 4 5 6 7 8 9 10

2 ☀

2.

3 ☀

1 2 3 4 5 6 7 8 9 10

9 ☀

3.

10 ☀

1 2 3 4 5 6 7 8 9 10

1 ☀

4.

4 ☀

1 2 3 4 5 6 7 8 9 10

6 ☀

Colorea los círculos que indican los números y únelos.

Rodea el número menor.

5.

○	○
○	○
○	○
○	○
○	○

1 **4**

6.

○	○
○	○
○	○
○	○
○	○

4 **2**

7.

○	○
○	○
○	○
○	○
○	○

3 **5**

8.

○	○
○	○
○	○
○	○
○	○
○	○

6 **2**

9.

○	○
○	○
○	○
○	○
○	○
○	○

3 **6**

10.

○	○
○	○
○	○
○	○
○	○
○	○

1 **5**

Colorea los círculos que indican los números y únelos.

Rodea el número menor.

11.

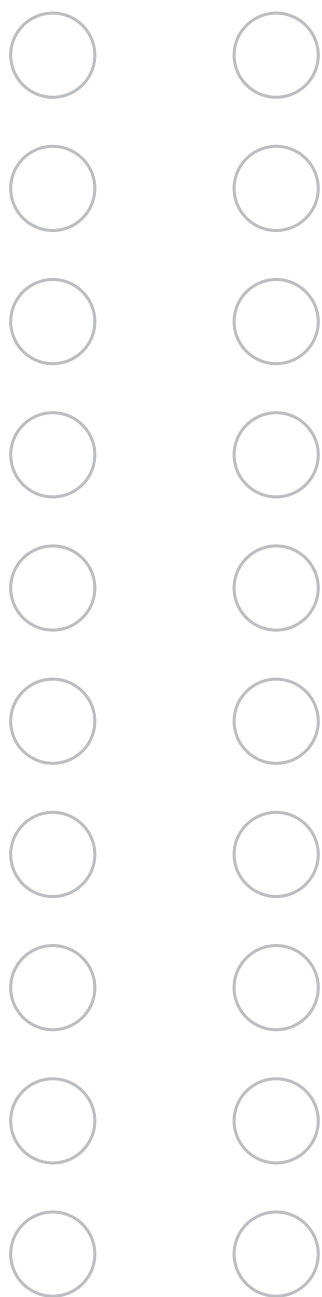

9

5

12.

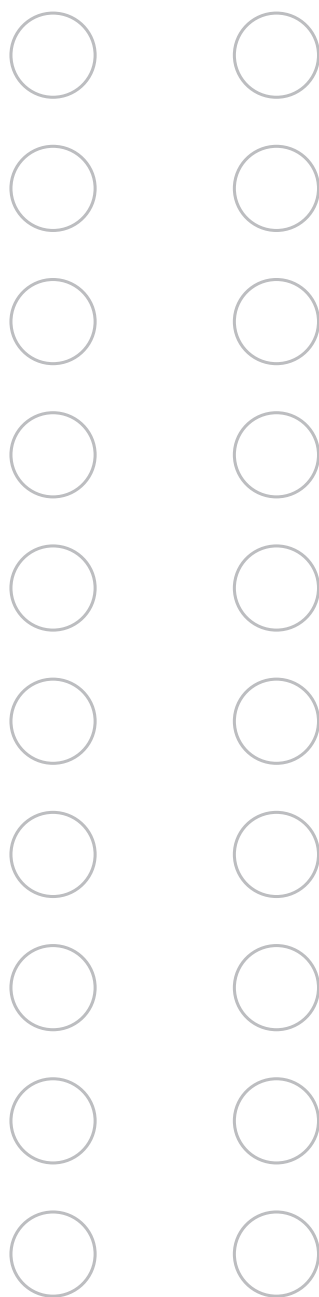

8

3

13.

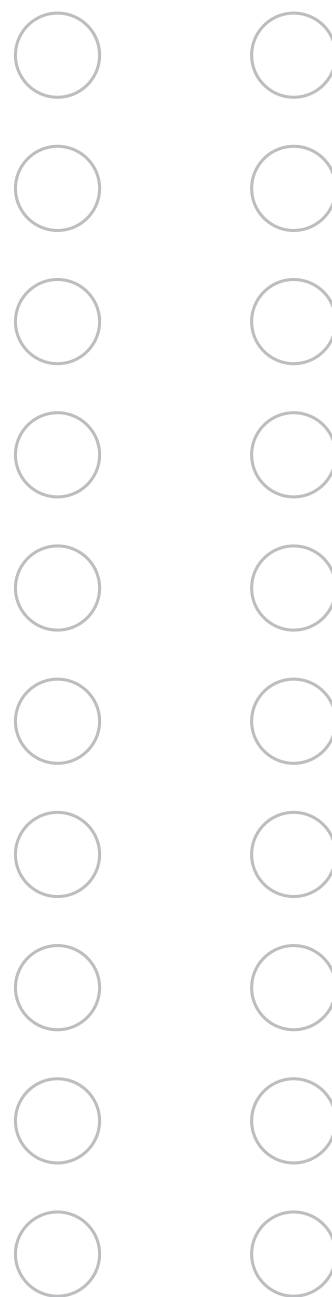

6

10

MDInf-1 Contar hasta el 60

Repasa.

1.

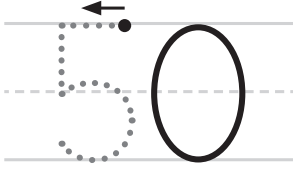
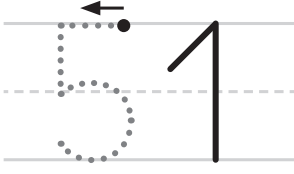
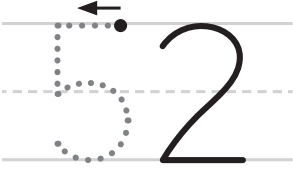
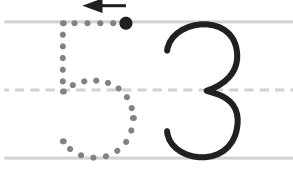
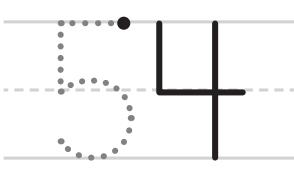
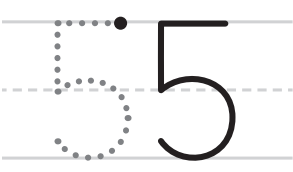
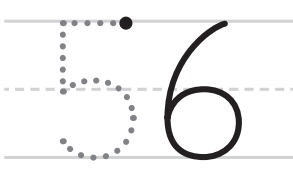
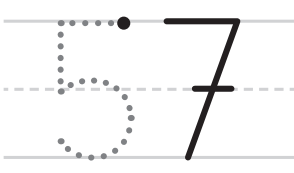
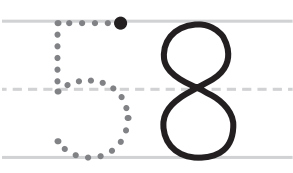
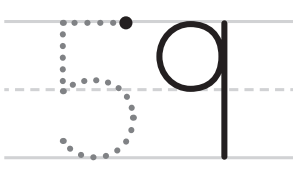
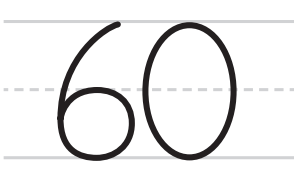
2.

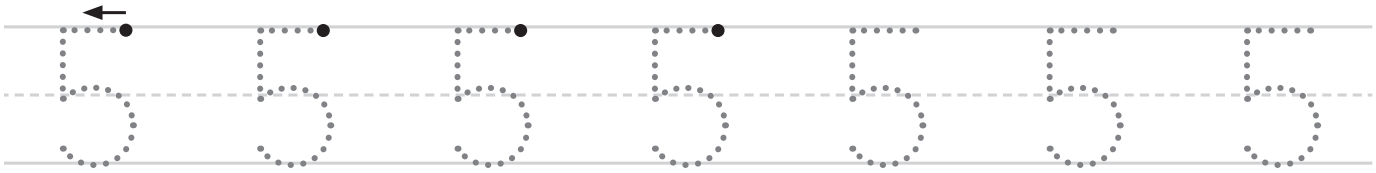

Escribe el 5.

3.



MDInf-2 Clasificar en dos grupos

¿A dónde pertenece cada figura?

Dibuja una línea.

1.

The diagram shows a classification task. On the left, there are seven geometric shapes: a small circle, a horizontal rectangle, a large circle, a vertical rectangle, a medium circle, a large horizontal rectangle, and a small vertical rectangle. On the right, there are two large rounded rectangular boxes. The top box contains a small circle in its upper section, and a line from the small circle on the left points to the middle of the box. The bottom box contains a horizontal rectangle in its upper section.

COPYRIGHT © 2017 JUMP MATH: PROHIBIDA LA REPRODUCCIÓN. EDICIÓN EN ESPAÑOL

¿A dónde pertenece cada figura?

Dibuja una línea.

2.

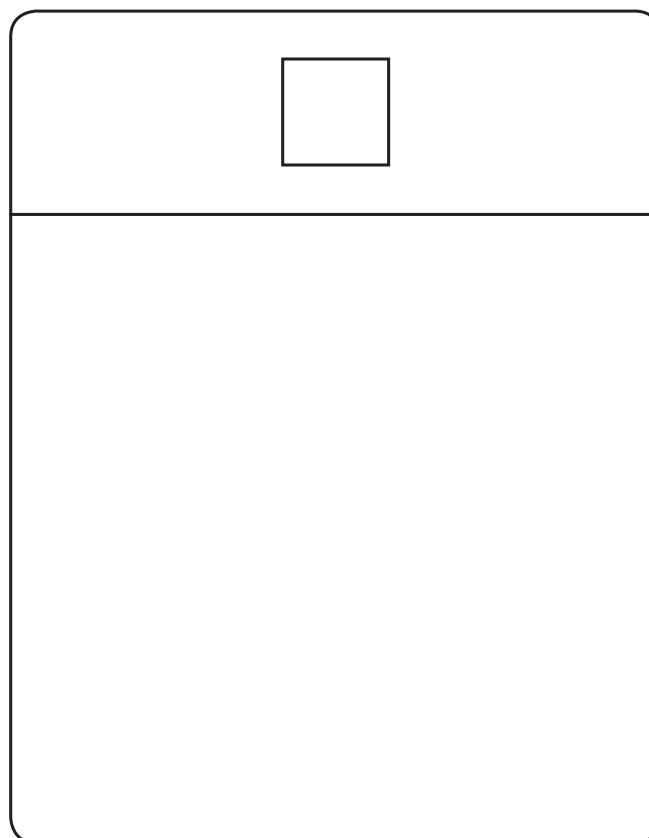
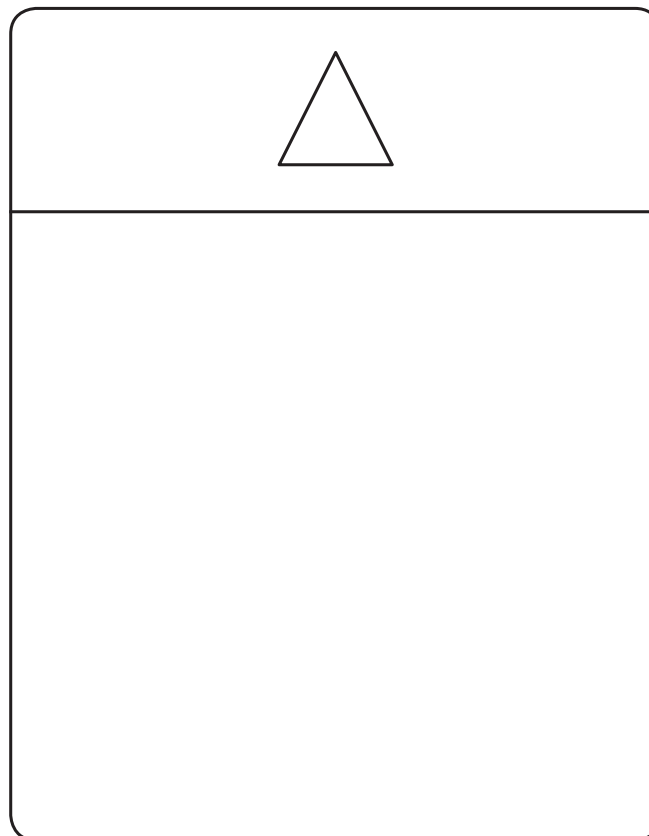
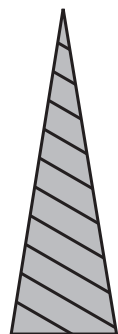
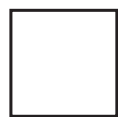
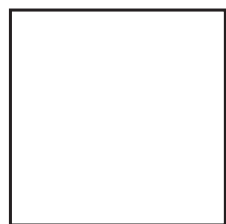
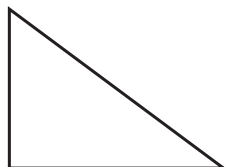
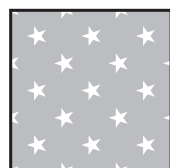
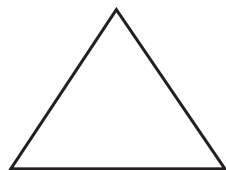

Escribe cuántos \triangle hay.

Escribe cuántos \square hay.

3.

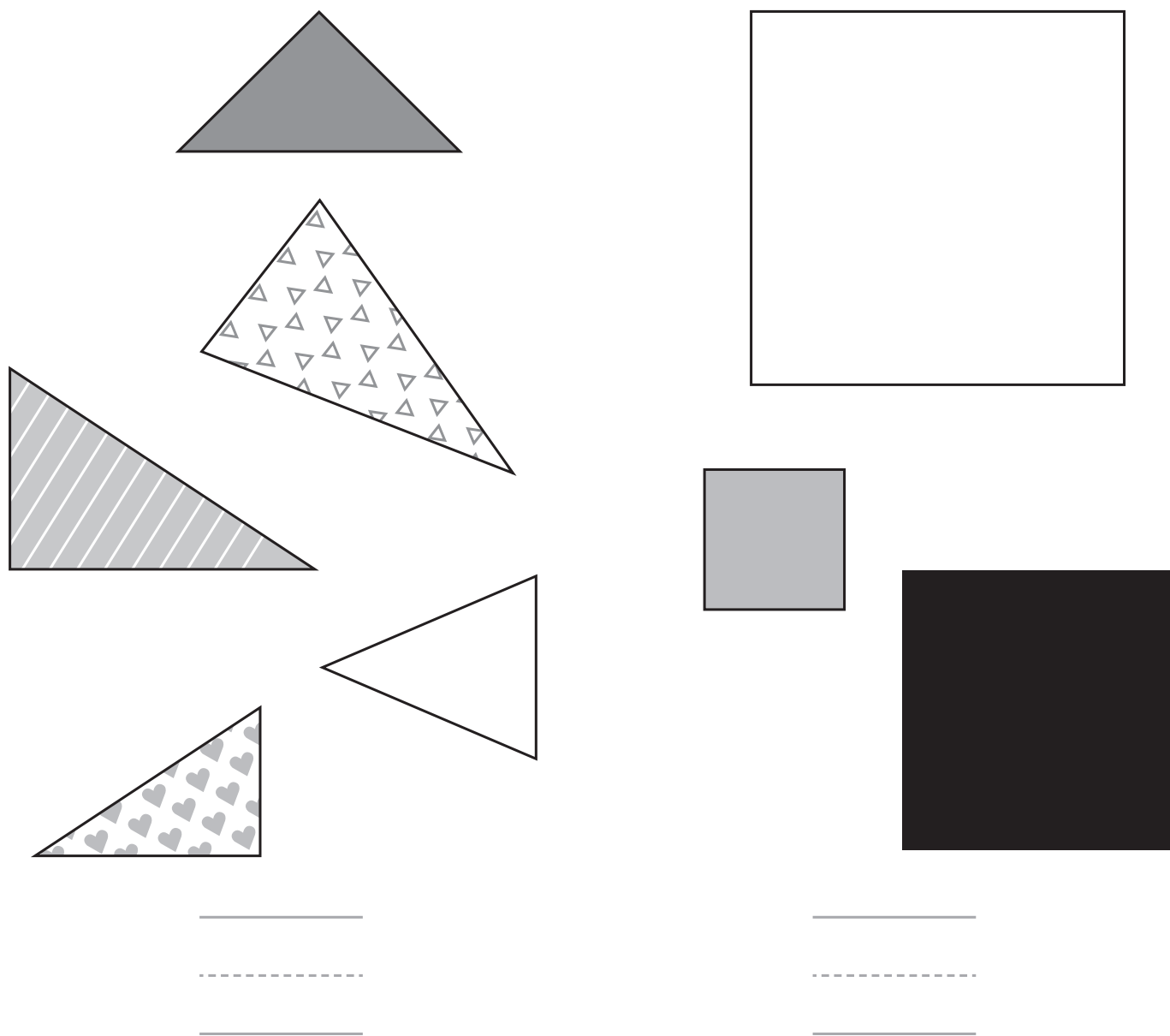

¿Hay más \triangle o \square ?

Rodea la respuesta.

4.



Escribe cuántos \triangle hay.

Escribe cuántos \square hay.

5.

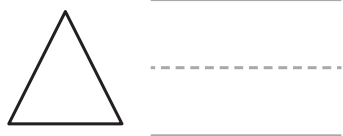
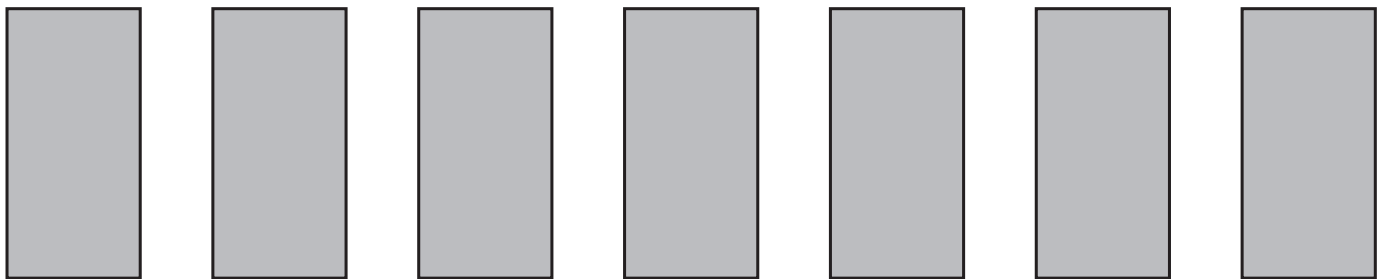
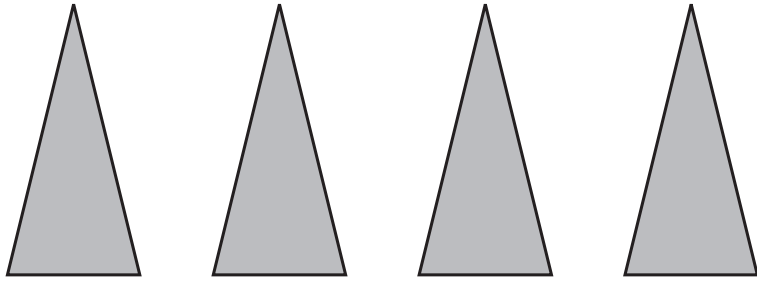

¿Hay más \triangle o \square ?

Rodea la respuesta.

6.

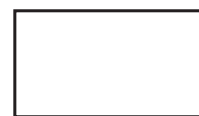

MDInf-3 Clasificar en tres grupos

¿A dónde pertenece cada figura?

Dibuja una línea.

1.

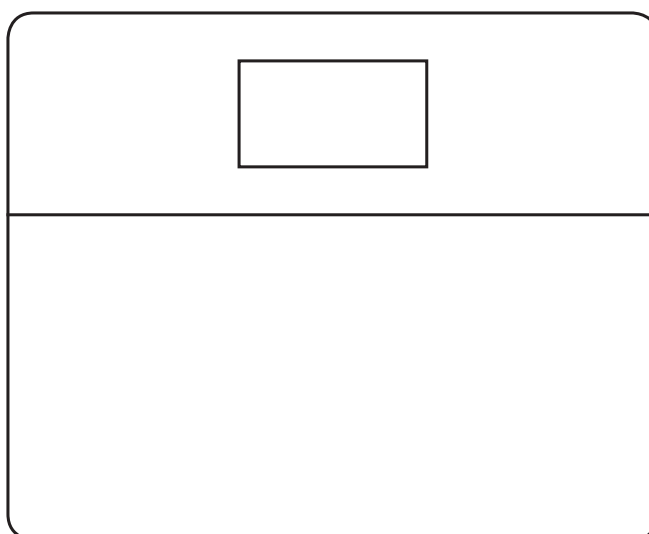
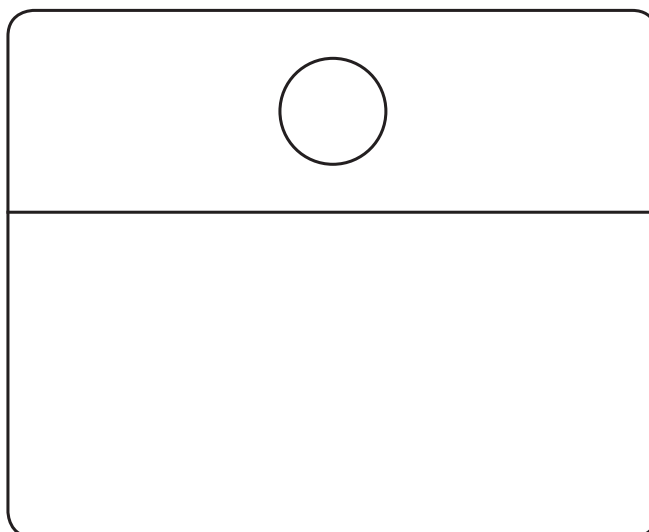
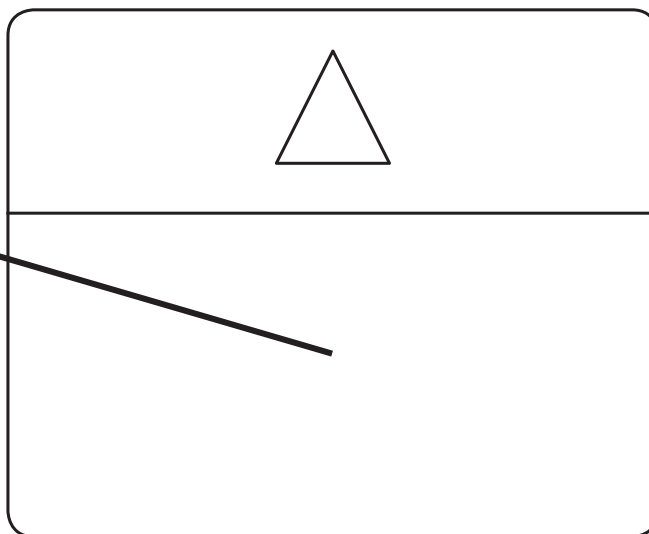
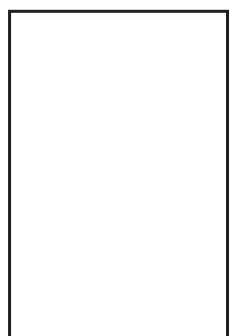
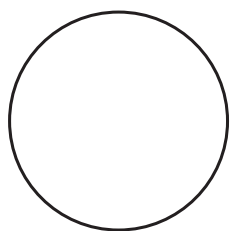
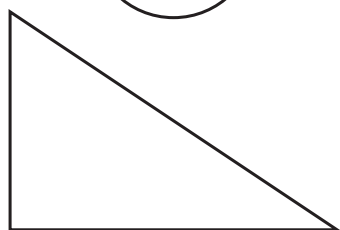
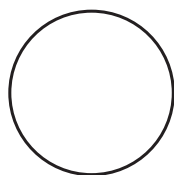
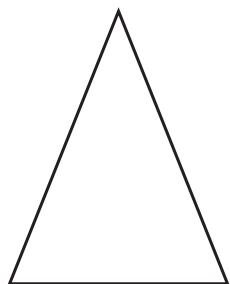
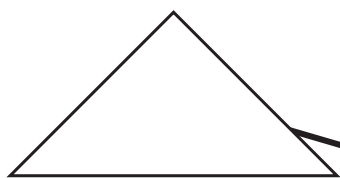

COPYRIGHT © 2017 JUMP MATH: PROHIBIDA LA REPRODUCCIÓN. EDICIÓN EN ESPAÑOL

¿A dónde pertenece cada figura?

Dibuja una línea.

2.

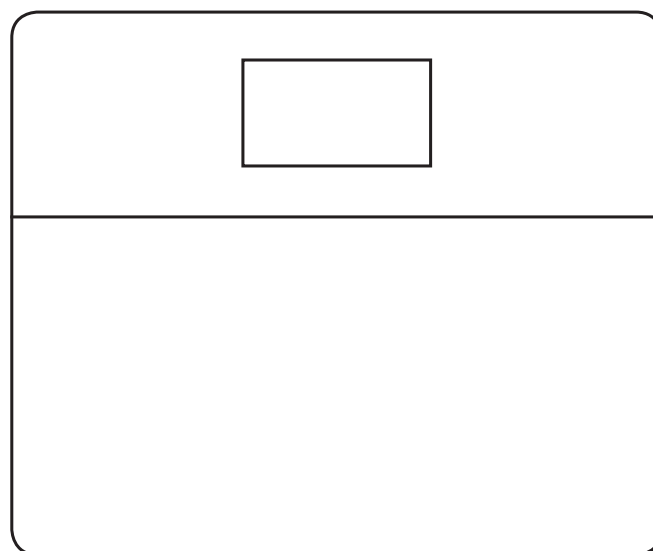
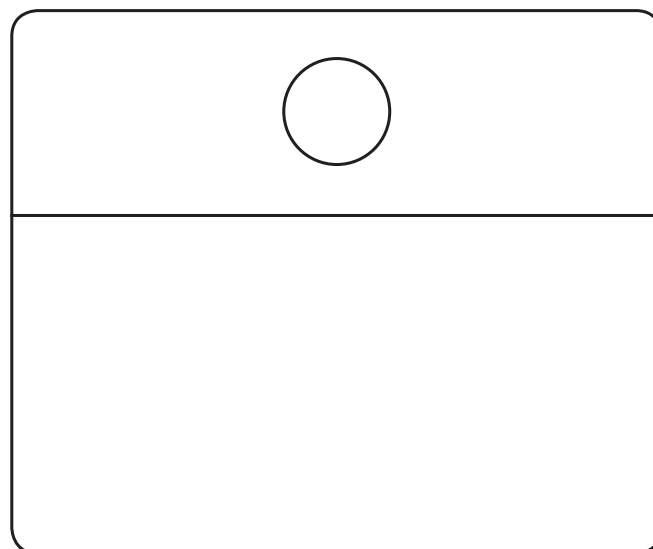
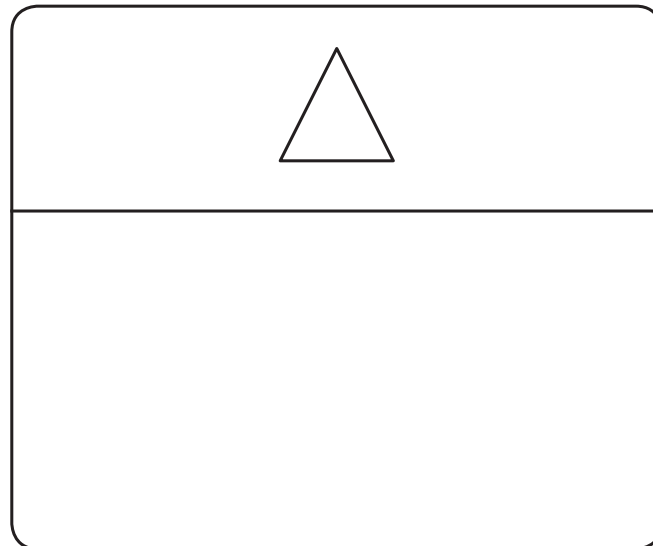
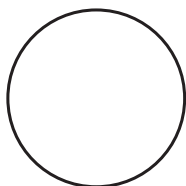
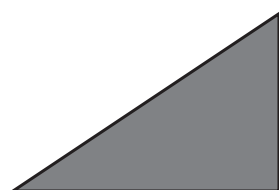
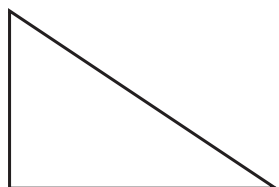
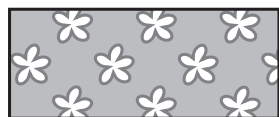
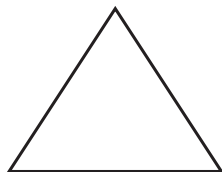

Escribe cuántos hay de cada figura.

3.

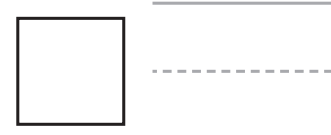
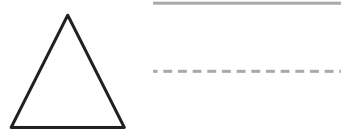
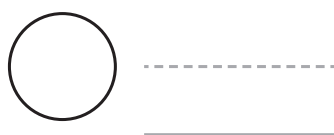
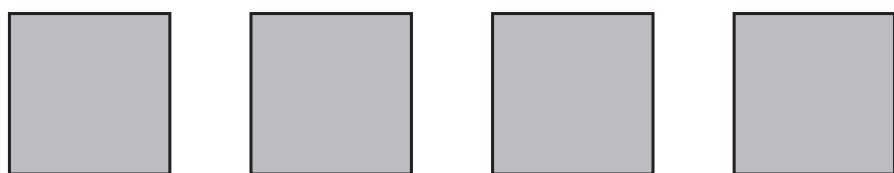
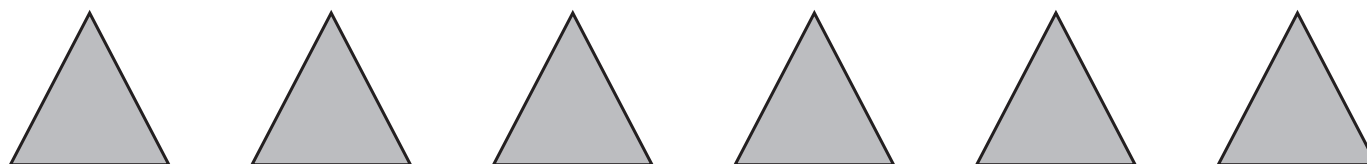
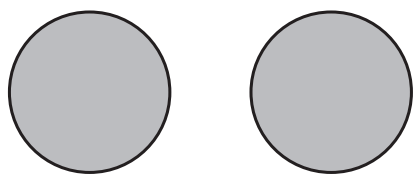

¿Hay más \triangle o \square ?

Rodea la respuesta.

4.



¿Cuántas piezas de cada fruta hay?

Dibuja una línea.

5.

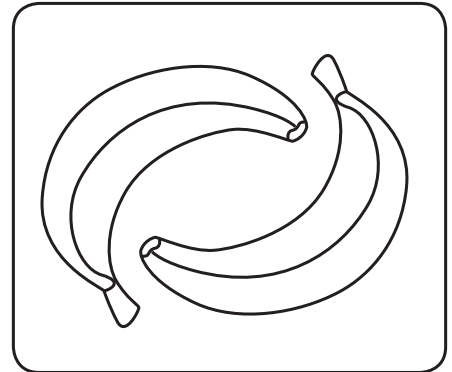
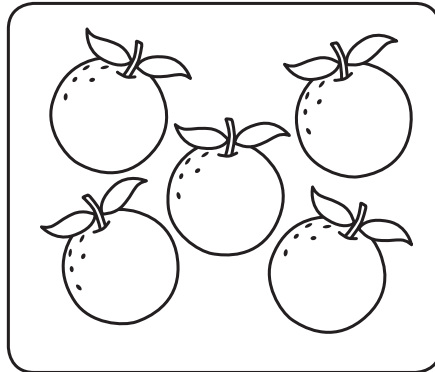
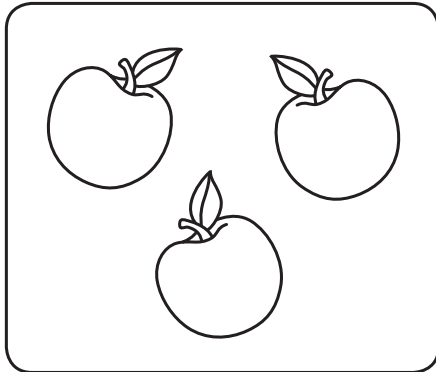

1	2	3	4	5
----------	----------	----------	----------	----------

6.

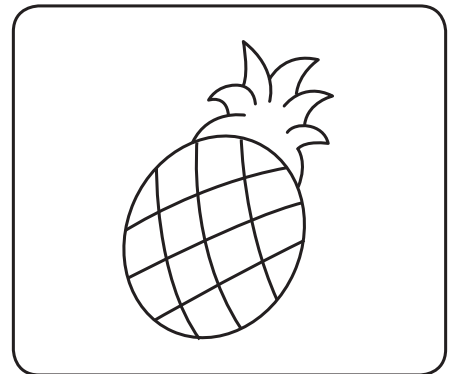
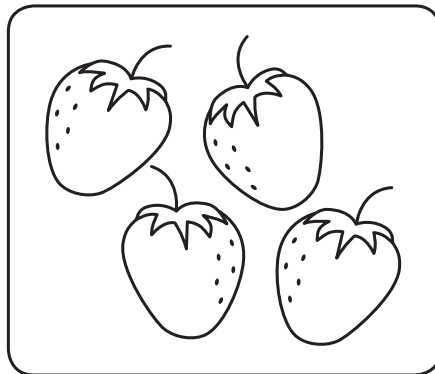
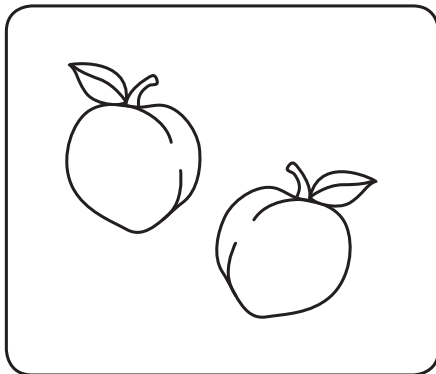

1	2	3	4	5
----------	----------	----------	----------	----------

MDInf-4 Varias maneras de clasificar

- Dibuja líneas para clasificar por colores.
- Dibuja líneas para clasificar por figuras.

1.

Negro

Gris

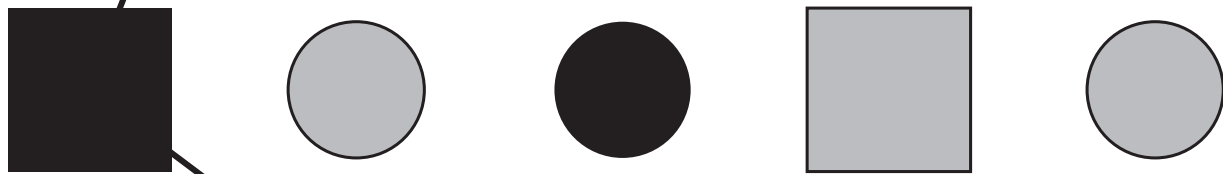

COPYRIGHT © 2017 JUMP MATH: PROHIBIDA LA REPRODUCCIÓN. EDICIÓN EN ESPAÑOL

- Dibuja líneas para clasificar por colores.
- Dibuja líneas para clasificar por figuras.

2.

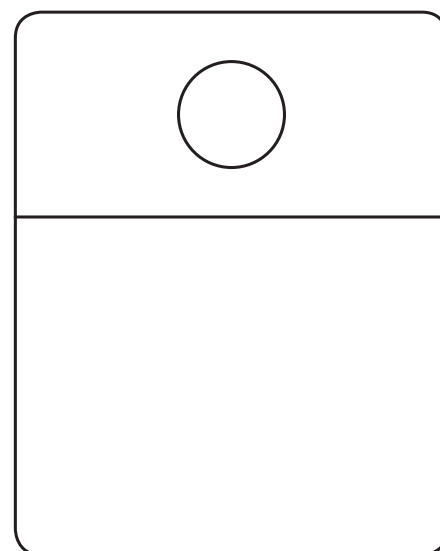
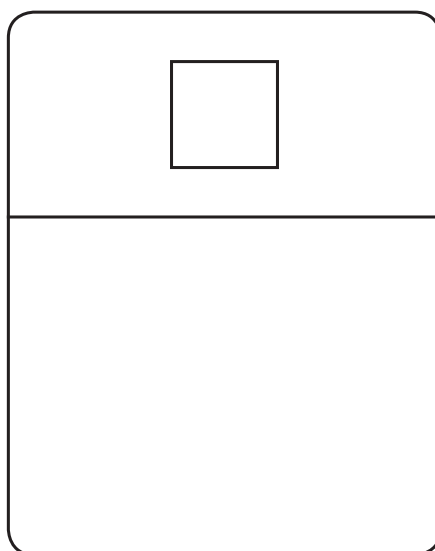
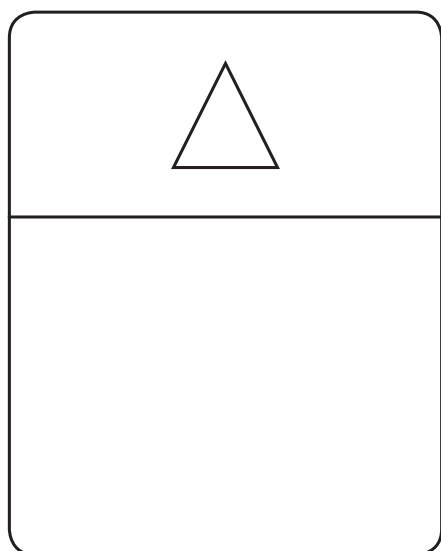
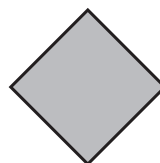
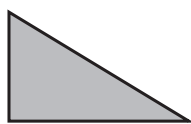
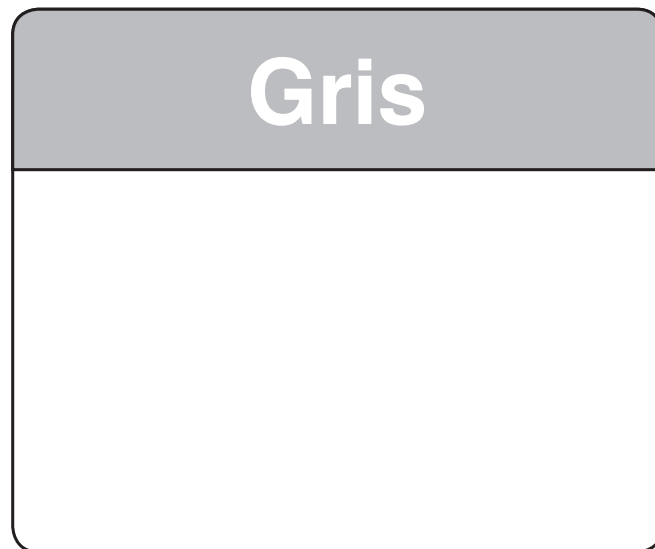
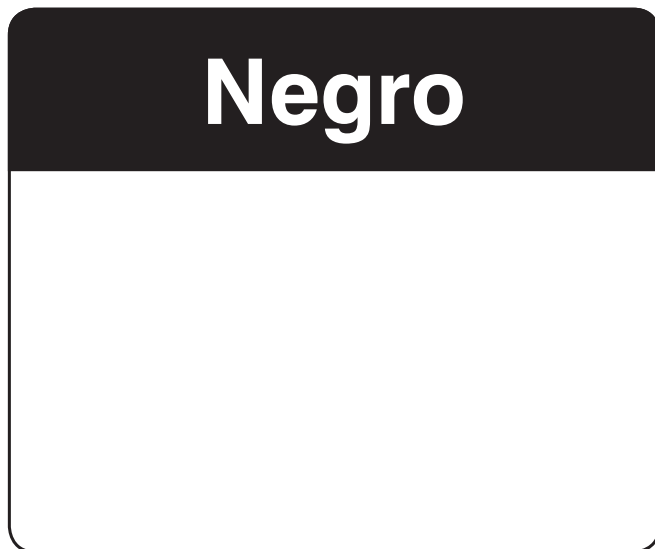

MDInf-5 Clasificar por número de esquinas y lados

¿Cuántas esquinas tienen?

Dibuja una línea.

1.

3 esquinas

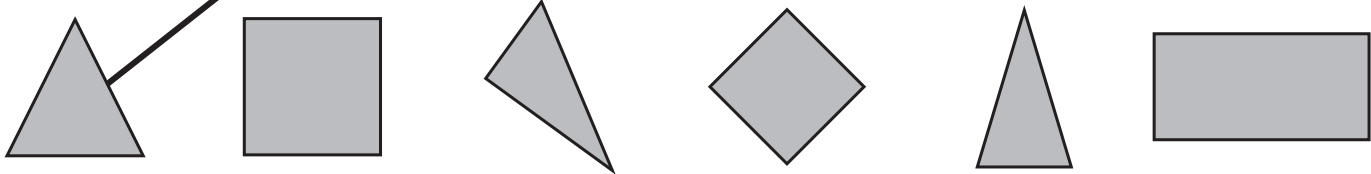

4 esquinas

COPYRIGHT © 2017 JUMP MATH: PROHIBIDA LA REPRODUCCIÓN. EDICIÓN EN ESPAÑOL

¿Cuántos lados tienen?

Dibuja una línea.

2.

3 lados

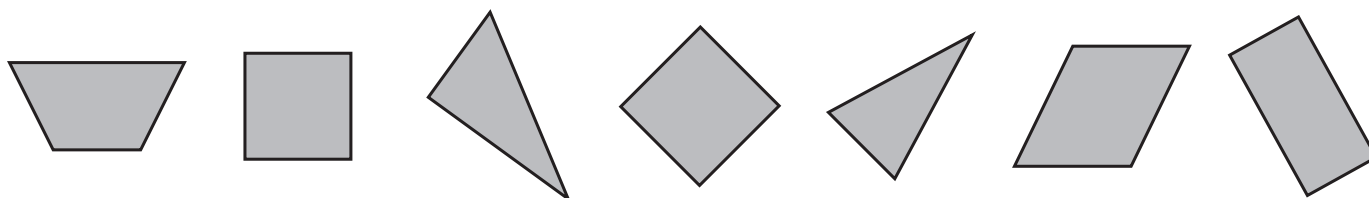

4 lados

